

NXP 0500 - 1650

Water-water multipurpose

Cooling capacity 108 ÷ 502 kW
Heating capacity 122 ÷ 549 kW



- Units designed for 2 or 4-pipe systems
- High efficiency also at partial loads
- Simultaneous and independent production of hot and chilled water



DESCRIPTION

Multi-purpose indoor model designed for applications with 2 or 4-pipe systems. Just one unit is capable of satisfying the yearly hot and cold water demand simultaneously and independently. The base, the structure and the panels are made of galvanized steel treated with polyester paint RAL 9003.

VERSIONS

- ° Standard
- L Standard silenced

FEATURES

Operating field

Work at full load with chilled water production from 4 to 18°C at the evaporator and hot water at the condenser up to 55 °C. (for more information, refer to the technical documentation).

Dual-circuit unit

The units are dual-circuit, to ensure maximum efficiency both at full load and at partial load.

Exchangers

All standard units have user-side heat exchangers and plate recovery, optimised to take advantage of the excellent heat exchange characteristics of the R410A.

Option integrated hydronic kit

To obtain a solution that offers economic savings and easy installation, these units can be configured with an integrated hydronic kit on both the service side and the recovery side.

The kit contains the main hydraulic components, and is available in various configurations with a single pump or a standby pump too, so the customer can choose the right useful head.

The flow switch is available as an accessory for both the system side and the recovery side, and is compulsory; if it is not installed, the warranty will be considered invalid.

CONTROL PCO⁵

Microprocessor adjustment, with keyboard and LCD display, for easy access on the unit is a menu available in several languages.

- Possibility to control two units in a Master-Slave configuration
- The presence of a programmable timer allows functioning time periods and a possible second set-point to be set.
- The temperature control takes place with the integral proportional logic, based on the water output temperature.

ACCESSORIES

AER485P1: RS-485 interface for supervision systems with MODBUS protocol.

AERBACP: Ethernet communication Interface for protocols Bacnet/IP, Modbus TCP/IP, SNMP

AERNET: The device allows the control, the management and the remote monitoring of a Chiller with a PC, smartphone or tablet using Cloud connection. AERNET works as Master while every unit connected is configured as Slave (max. 6 unit); also, with a simple click is possible to save a log file with all the connected unit datas in the personal terminal for post analysis.

FL: Flow switch.

MULTICHILLER_EVO: Control, switch-on and switch-off system of the single chillers where multiple units are installed in parallel, always ensuring constant flow rate to the evaporators.

PGD1: Allows you to control the unit at a distance.

AVX: Spring anti-vibration supports.

FACTORY FITTED ACCESSORIES

DRE: Electronic device for peak current reduction.

RIF: Power factor correction. Connected in parallel to the motor allowing about 10% reduction of input current.

ACCESSORIES COMPATIBILITY

Model	Ver	0500	0550	0600	0650	0700	0750	0800	0900	1000	1250	1400	1500	1650
AER485P1	°L	*	*	*	*	*	*	*	*	*	*	*	*	*
AERBACP	°L	*	*	*	*	*	*	*	*	*	*	*	*	*
AERNET	°L	*	*	*	*	*	*	*	*	*	*	*	*	*
FL	°L	*	*	*	*	*	*	*	*	*	*	*	*	*
MULTICHILLER_EVO	°L	*	*	*	*	*	*	*	*	*	*	*	*	*
PGD1	°L	*	*	*	*	*	*	*	*	*	*	*	*	*

Antivibration

Version	System side - pumps	Recovery side - pumps	0500	0550	0600	0650	0700	0750	0800
°	°	°	AVX350	AVX350	AVX351	AVX351	AVX351	AVX351	AVX352
°	°	U,V	AVX357	AVX357	AVX358	AVX358	AVX358	AVX358	AVX360
°	M,N	°U,V,W,Z	AVX357	AVX357	AVX358	AVX358	AVX358	AVX358	AVX360
°	O,P	U,V	AVX357	AVX357	AVX358	AVX358	AVX358	AVX359	AVX360
°	°	W,Z	AVX357	AVX357	AVX359	AVX359	AVX359	AVX359	AVX363
°	O,P	°W,Z	AVX357	AVX357	AVX359	AVX359	AVX359	AVX359	AVX363
L	°	°	AVX351	AVX351	AVX355	AVX355	AVX355	AVX355	AVX353
L	°	U,V	AVX358	AVX358	AVX359	AVX359	AVX359	AVX359	AVX360
L	M,N	°U,V	AVX358	AVX358	AVX359	AVX359	AVX359	AVX359	AVX360
L	°M,N	W,Z	AVX359	AVX359	AVX359	AVX359	AVX359	AVX359	AVX363
L	O,P	°U,V,W,Z	AVX359	AVX359	AVX359	AVX359	AVX359	AVX359	AVX363

Version	System side - pumps	Recovery side - pumps	0900	1000	1250	1400	1500	1650
°	°	°	AVX352	AVX353	AVX353	AVX353	AVX354	AVX354
°	°	U,V	AVX360	AVX361	AVX361	AVX361	AVX361	AVX361
°	M,N	°U,V,W,Z	AVX360	AVX361	AVX361	AVX361	AVX361	AVX361
°	O,P	U,V	AVX360	AVX361	AVX361	AVX361	AVX361	AVX361
°	°	W,Z	AVX363	AVX364	AVX364	AVX364	AVX364	AVX364
°	O,P	°W,Z	AVX363	AVX364	AVX364	AVX364	AVX364	AVX364
L	°	°	AVX353	AVX353	AVX354	AVX354	AVX354	AVX354
L	°	U,V	AVX360	AVX361	AVX361	AVX362	AVX362	AVX362
L	M,N	°U,V	AVX360	AVX361	AVX361	AVX362	AVX362	AVX362
L	°M,N	W,Z	AVX364	AVX364	AVX364	AVX364	AVX364	AVX364
L	O,P	°U,V,W,Z	AVX364	AVX364	AVX364	AVX364	AVX364	AVX364

Device for peak current reduction

Ver	0500	0550	0600	0650	0700	0750	0800	0900	1000	1250	1400	1500	1650
°L	DRES01 (1)	DRES51 (1)	DRE601 (1)	DRE651 (1)	DRE701 (1)	DRE751 (1)	DRE801 (1)	DRE901 (1)	DRE1001 (1)	DRE1251 (1)	DRE1401 (1)	DRE1401 (1)	DRE1401 (1)

(1) Only for supplies of 400V 3N ~ 50Hz and 400V 3 ~ 50Hz. x 2 or x 3 (if present) indicates the quantity to be ordered.

A grey background indicates the accessory must be assembled in the factory

Power factor correction

Ver	0500	0550	0600	0650	0700	0750	0800	0900	1000	1250	1400	1500	1650
°L	RIF98	RIF98	RIF95	RIF95	RIF95	RIF95	RIF95	RIF95	RIF96	RIF97	RIF97	RIF97	RIF97

A grey background indicates the accessory must be assembled in the factory

CONFIGURATOR

Configuration options

Field	Description
1,2,3	NXP
4,5,6,7	Size 0500, 0550, 0600, 0650, 0700, 0750, 0800, 0900, 1000, 1250, 1400, 1500, 1650
8	Operating field
°	Standard mechanic thermostatic valve
9	System type
2	2-pipe system
4	4-pipe system
10	Version
°	Standard
L	Standard silenced
11	Power supply
°	400V ~ 3 50Hz with magnet circuit breakers
4	220V ~ 3 50Hz with magnet circuit breakers (1)
5	500V ~ 3 50Hz with magnet circuit breakers (2)
12	System side - pumps
°	Without hydronic kit
M	Single pump low head
N	Pump low head + stand-by pump
O	Single pump high head
P	Pump high head + stand-by pump
13	Recovery side - pumps
°	Without hydronic kit
U	Single pump low head
V	Pump low head + stand-by pump
W	Single pump high head
Z	Pump high head + stand-by pump

(1) Only for sizes from 0500 to 0700

(2) Only for sizes from 0800 to 1000

PERFORMANCE SPECIFICATIONS

NXP - 2-pipe system versions °/L

Size		0500	0550	0600	0650	0700	0750	0800	0900	1000	1250	1400	1500	1650
Cooling system side 2-pipe system (1)														
Cooling capacity	kW	108,9	117,0	141,5	157,5	192,7	218,5	252,2	281,0	305,8	345,2	392,3	447,2	502,4
Input power	kW	24,0	26,1	30,9	35,1	42,6	48,9	56,0	62,5	66,3	75,7	85,2	98,4	110,3
Cooling input current	A	47,0	50,0	58,0	65,0	84,0	90,0	92,0	101,0	106,0	135,0	149,0	169,0	188,0
EER	W/W	4,54	4,48	4,58	4,49	4,52	4,47	4,51	4,50	4,61	4,56	4,60	4,55	4,55
Water flow rate source side	l/h	22711	24436	29455	32877	40143	45586	52705	58706	63673	71963	81633	93177	104621
Pressure drop source side	kPa	33	37	41	50	59	69	28	34	26	32	36	45	49
Water flow rate system side	l/h	18734	20124	24349	27108	33155	37599	43386	48338	52596	59364	67464	76904	86389
Pressure drop system side	kPa	19	21	21	25	27	29	20	25	19	23	26	32	34
Heating system side 2-pipe system (2)														
Heating capacity	kW	122,4	131,0	158,2	175,7	210,0	238,7	289,0	320,9	352,6	383,7	433,5	489,5	549,4
Input power	kW	29,6	32,0	38,5	43,3	51,7	59,6	70,9	79,3	84,0	91,7	103,4	118,6	132,1
Heating input current	A	54,0	58,0	68,0	76,0	95,0	103,0	112,0	123,0	130,0	154,0	173,0	196,0	217,0
COP	W/W	4,13	4,09	4,11	4,05	4,06	4,00	4,08	4,05	4,20	4,18	4,19	4,13	4,16
Water flow rate source side	l/h	27209	29066	35169	38937	46642	52841	63935	70917	78660	85555	96778	108934	122632
Pressure drop source side	kPa	47	52	58	69	79	92	41	50	39	45	51	62	67
Water flow rate system side	l/h	21232	22726	27452	30476	36453	41427	50177	55720	61233	66632	75270	84987	95403
Pressure drop system side	kPa	25	27	27	32	32	36	27	33	25	29	32	39	42
Heating domestic hot water side 2-pipe system (3)														
Heating capacity	kW	124,5	133,2	161,0	178,8	213,6	242,8	293,3	325,1	354,8	390,1	439,8	496,5	558,6
Input power	kW	29,2	31,6	37,8	42,6	50,9	58,4	70,0	78,4	83,2	91,1	102,6	117,8	131,6
Heating total input current	A	54,0	57,0	67,0	75,0	95,0	103,0	110,0	122,0	129,0	153,0	171,0	194,0	216,0
COP	W/W	4,26	4,21	4,26	4,20	4,19	4,16	4,19	4,15	4,26	4,28	4,29	4,21	4,24
Water flow rate source side	l/h	27905	29767	36085	39952	47734	54174	65416	72379	79441	87568	98845	111238	125462
Pressure drop source side	kPa	37	42	41	50	53	58	42	50	38	46	52	66	70
Water flow rate domestic hot water side	l/h	21604	23109	27936	31015	37062	42149	50928	56446	61601	67743	76363	86215	96994
Pressure drop domestic hot water side	kPa	23	26	25	30	33	36	26	32	23	28	33	40	43
Simultaneous operation (heating + cooling), 2 pipes (4)														
Cooling capacity	kW	96,2	102,5	124,8	138,9	165,4	190,6	225,7	250,3	282,6	308,1	340,2	392,0	444,9
Recovered heating power	kW	123,3	131,9	160,0	178,4	212,6	244,6	290,8	322,7	360,1	392,6	435,1	500,6	566,0
Input power	kW	28,2	30,5	36,5	40,9	49,0	56,2	67,8	75,5	80,9	88,2	99,2	113,9	126,6
Water flow rate system side	l/h	18734	20124	24349	27108	33155	37599	43386	48338	52596	59364	67464	76904	86389
Pressure drop system side	kPa	19	21	21	25	27	29	20	25	19	23	26	32	34
Water flow rate domestic hot water side	l/h	21604	23109	27936	31015	37062	42149	50928	56446	61601	67743	76363	86215	96994
Pressure drop domestic hot water side	kPa	23	26	25	30	33	36	26	32	23	28	33	40	43

(1) Date 14511:2022; Water user side 12 °C / 7 °C; Water source side 30 °C / 35 °C; All the units are Eurovent certified

(2) Date 14511:2022; Water user side 40 °C / 45 °C; Water source side 10 °C / 7 °C

(3) Water exchanger to the total recovery side 40 °C / 45 °C; Water source side 10 °C / 7 °C

(4) Water exchanger to the total recovery side * / 45 °C; Water to the system side heat exchanger * / 7 °C;

NXP - 4-pipe system versions °/L

Size		0500	0550	0600	0650	0700	0750	0800	0900	1000	1250	1400	1500	1650
Cooling system side 4-pipe system (1)														
Cooling capacity	kW	108,9	117,0	141,5	154,5	192,7	218,5	252,2	281,0	305,8	345,2	392,3	447,2	502,4
Input power	kW	24,0	26,1	30,9	35,1	42,6	48,9	56,0	62,5	66,3	75,7	85,2	98,4	110,3
Cooling input current	A	47,0	50,0	58,0	65,0	84,0	90,0	92,0	101,0	106,0	135,0	149,0	169,0	188,0
EER	W/W	4,54	4,48	4,58	4,49	4,52	4,47	4,51	4,50	4,61	4,56	4,60	4,55	4,55
Water flow rate source side	l/h	22711	24436	29455	32877	40143	45586	52705	58706	63673	71963	81633	93177	104621
Pressure drop source side	kPa	33	37	41	50	59	69	28	34	26	32	36	45	49
Water flow rate system side	l/h	18734	20124	24349	27108	33155	37599	43386	48338	52596	59364	67464	76904	86389
Pressure drop system side	kPa	19	21	21	25	27	29	20	25	19	23	26	32	34
Heating system side 4-pipe system (2)														
Heating capacity	kW	124,5	133,2	161,0	178,8	213,6	242,8	293,3	325,1	354,8	390,1	439,8	496,5	558,6
Input power	kW	29,2	31,6	37,8	42,6	50,9	58,4	70,0	78,4	83,2	91,1	102,6	117,8	131,6
Heating total input current	A	54,0	57,0	67,0	75,0	95,0	103,0	110,0	122,0	129,0	153,0	171,0	194,0	216,0
COP	W/W	4,26	4,21	4,26	4,20	4,19	4,16	4,19	4,15	4,26	4,28	4,29	4,21	4,24
Water flow rate source side	l/h	27905	29767	36085	39952	47734	54174	65416	72379	79441	87568	98845	111238	125462
Pressure drop source side	kPa	37	42	41	50	53	58	42	50	38	46	52	66	70
Water flow rate system side	l/h	21604	23109	27936	31015	37062	42149	50928	54446	61601	67743	76363	86215	96994
Pressure drop system side	kPa	23	26	25	30	33	36	26	32	23	28	33	40	43
Simultaneous operation (heating + cooling), 4 pipes (3)														
Cooling capacity	kW	96,2	102,5	124,8	138,9	165,4	190,6	225,7	250,3	282,6	308,1	340,2	392,0	444,9
Recovered heating power	kW	123,3	131,9	160,0	178,4	212,6	244,6	290,8	322,7	360,1	392,6	435,1	500,6	566,0
Input power	kW	28,2	30,5	36,5	40,9	49,0	56,2	67,8	75,5	80,9	88,2	99,2	113,4	126,6
Water flow rate cold side	l/h	18734	20124	24349	27108	33155	37599	43386	48338	52596	59364	67464	76904	86389
Pressure drop cold side	kPa	19	21	21	25	27	29	20	25	19	23	26	32	34
Water flow rate hot side	l/h	21604	23109	27936	31015	37062	42149	50928	56446	61601	67743	76363	86215	96994

(1) Date 14511:2022; Water user side 12 °C / 7 °C; Water source side 30 °C / 35 °C; All the units are Eurovent certified

(2) Date 14511:2022; Water user side 40 °C / 45 °C; Water source side 10 °C / 7 °C

(3) Water exchanger to the total recovery side * / 45 °C; Water to the system side heat exchanger * / 7 °C;

Size		0500	0550	0600	0650	0700	0750	0800	0900	1000	1250	1400	1500	1650
Pressure drop hot side	kPa	23	26	25	30	33	36	26	32	23	28	33	40	43

(1) Date 14511:2022; Water user side 12 °C / 7 °C; Water source side 30 °C / 35 °C; All the units are Eurovent certified

(2) Date 14511:2022; Water user side 40 °C / 45 °C; Water source side 10 °C / 7 °C

(3) Water exchanger to the total recovery side * / 45 °C; Water to the system side heat exchanger * / 7 °C;

ENERGY INDICES (REG. 2016/2281 EU)

Size		0500	0550	0600	0650	0700	0750	0800	0900	1000	1250	1400	1500	1650
SEER - 12/7 (EN14825: 2018) (1)														
SEER	°L W/W	5,25	5,44	5,52	5,43	5,52	5,39	5,61	5,82	6,09	6,00	6,05	6,43	6,45
Seasonal efficiency	°L %	207,0%	214,6%	217,8%	214,2%	217,8%	212,6%	221,4%	229,9%	240,5%	237,1%	239,1%	254,2%	254,9%
SEPR - (EN 14825: 2018) High temperature (2)														
SEPR	°L W/W	-	-	-	-	-	-	-	7,08	7,30	7,21	7,23	-	-
UE 813/2013 performance in average ambient conditions (average) - 55 °C - Pdesignh ≤ 400 kW (3)														
Pdesignh	°L kW	163	173	212	234	280	318	385	-	-	-	-	-	-
SCOP	°L W/W	4,78	4,68	4,78	4,65	4,65	4,58	4,73	-	-	-	-	-	-
ηsh	°L %	183,0%	179,0%	183,0%	178,0%	178,0%	175,0%	181,0%	-	-	-	-	-	-
Energy index														
TER	°L W/W	7,77	7,68	7,80	7,75	7,71	7,75	7,62	7,59	7,94	7,94	7,82	7,87	7,99

(1) Calculation performed with FIXED water flow rate and VARIABLE outlet temperature.

(2) Calculation performed with FIXED water flow rate.

(3) Efficiencies for average temperature applications (55 °C)

ELECTRIC DATA

Size		0500	0550	0600	0650	0700	0750	0800	0900	1000	1250	1400	1500	1650
Electric data														
Maximum current (FLA)	°L A	71,0	77,0	91,0	102,0	124,0	135,0	163,0	179,0	195,0	208,0	237,0	266,0	295,0
Peak current (LRA)	°L A	214,0	220,0	206,0	216,0	267,0	323,0	332,0	340,0	356,0	459,0	488,0	600,0	629,0

GENERAL TECHNICAL DATA

Size		0500	0550	0600	0650	0700	0750	0800	0900	1000	1250	1400	1500	1650	
Compressor															
Type	°L type	Scroll													
Number	°L no.	3	3	4	4	4	4	4	4	4	4	4	4	4	
Circuits	°L no.	2	2	2	2	2	2	2	2	2	2	2	2	2	
Refrigerant	°L type	R410A													
2-pipe system - System side heat exchanger (hot/cold)															
Type	°L type	Braze plate													
Number	°L no.	1	1	1	1	1	1	1	1	1	1	1	1	1	
Connections (in/out)	°L Type	Grooved joints													
Sizes (in/out)	°L Ø	2" 1/2	2" 1/2	2" 1/2	2" 1/2	2" 1/2	2" 1/2	2" 1/2	3"	3"	3"	3"	3"	3"	
2-pipe system - Recovery side heat exchanger (domestic hot water)															
Type	°L type	Braze plate													
Number	°L no.	1	1	1	1	1	1	1	1	1	1	1	1	1	
Connections (in/out)	°L Type	Grooved joints													
Sizes (in/out)	°L Ø	2" 1/2	2" 1/2	2" 1/2	2" 1/2	2" 1/2	2" 1/2	2" 1/2	3"	3"	3"	3"	3"	3"	
4-pipe system - System side heat exchanger (cold side)															
Type	°L type	Braze plate													
Number	°L no.	1	1	1	1	1	1	1	1	1	1	1	1	1	
Connections (in/out)	°L Type	Grooved joints													
Sizes (in/out)	°L Ø	2" 1/2	2" 1/2	2" 1/2	2" 1/2	2" 1/2	2" 1/2	2" 1/2	3"	3"	3"	3"	3"	3"	
4-pipe system - Recovery side heat exchanger (hot side)															
Type	°L type	Braze plate													
Number	°L no.	1	1	1	1	1	1	1	1	1	1	1	1	1	
Connections (in/out)	°L Type	Grooved joints													
Sizes (in/out)	°L Ø	2" 1/2	2" 1/2	2" 1/2	2" 1/2	2" 1/2	2" 1/2	2" 1/2	3"	3"	3"	3"	3"	3"	
Sound data calculated in cooling mode (1)															
Sound power level	°	dB(A)	78,0	79,0	79,0	80,0	82,0	86,0	88,0	88,0	88,0	90,0	90,0	92,0	92,0
	L	dB(A)	72,0	73,0	73,0	74,0	76,0	80,0	82,0	82,0	82,0	84,0	84,0	86,0	86,0
Sound pressure level (10 m)	°	dB(A)	46,0	47,0	47,0	48,0	50,0	54,0	56,0	56,0	56,0	58,0	58,0	60,0	60,0
	L	dB(A)	40,0	41,0	41,0	42,0	44,0	48,0	50,0	50,0	50,0	52,0	52,0	54,0	54,0

(1) Sound power calculated on the basis of measurements made in accordance with UNI EN ISO 9614-2, as required for Eurovent certification. Sound pressure (cold functioning) measured in free field, 10m away from the unit external surface (in compliance with UNI EN ISO 3744).

DIMENSIONS

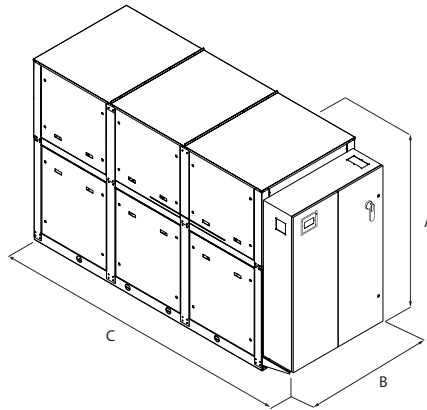

Size		0500	0550	0600	0650	0700	0750	0800	0900	1000	1250	1400	1500	1650
Dimensions and weights														
A	°	mm	1976	1976	1976	1976	1976	1976	2021	2021	2021	2021	2021	2021
	L	mm	2120	2120	2120	2120	2120	2120	2120	2120	2120	2120	2120	2120
B	°L	mm	1250	1250	1250	1250	1250	1250	1250	1250	1250	1250	1250	1250
C	°L	mm	2600	2600	2600	2600	2600	2600	2600	2600	2600	2600	2600	2600
Dimensions and weights with pump/s														
A	°	mm	1976	1976	1976	1976	1976	1976	2021	2021	2021	2021	2021	2021
	L	mm	2120	2120	2120	2120	2120	2120	2120	2120	2120	2120	2120	2120
B	°L	mm	1250	1250	1250	1250	1250	1250	1250	1250	1250	1250	1250	
C	°	mm	3452	3452	3452	3452	3452	3452	3452	3452	3750	3750	3750	3750
	L	mm	3452	3452	3452	3452	3452	3750	3750	3750	3750	2600	2600	2600

Version	System side - pumps	Recovery side - pumps		0500	0550	0600	0650	0700	0750
				kg	990	1000	1110	1130	1180
°	°	U/V	kg	1230	1240	1360	1380	1450	1690
°	M/N	°/U/V	kg	1230	1240	1360	1380	1450	1690
°	°/M/N	W/Z	kg	1340	1350	1490	1500	1600	1880
°	O/P	°/U/V/W/Z	kg	1340	1350	1490	1500	1600	1880
L	°	°	kg	1230	1230	1340	1360	1420	1570
L	°	U/V	kg	1560	1570	1690	1710	1780	2020
L	M/N	°/U/V	kg	1560	1570	1690	1710	1780	2020
L	°/M/N	W/Z	kg	1670	1680	1820	1830	1930	2210
L	O/P	°/U/V/W/Z	kg	1670	1680	1820	1830	1930	2210

Version	System side - pumps	Recovery side - pumps		0800	0900	1000	1250	1400	1500	1650
				kg	1680	1700	1890	1960	2060	2100
°	°	U/V	kg	1960	2060	2310	2380	2500	2540	2720
°	M/N	°/U/V	kg	1960	2060	2310	2380	2500	2540	2720
°	°/M/N	W/Z	kg	2110	2300	2560	2630	2770	2810	3010
°	O/P	°/U/V/W/Z	kg	2110	2300	2560	2630	2770	2810	3010
L	°	°	kg	1910	1930	2120	2190	2270	2400	2500
L	°	U/V	kg	2290	2390	2660	2730	2850	2890	3070
L	M/N	°/U/V	kg	2290	2390	2660	2730	2850	2890	3070
L	°/M/N	W/Z	kg	2240	2630	2910	2980	3120	3160	3360
L	O	°/U/V/W/Z	kg	2240	2630	2910	2980	3120	3160	3360
L	P	°/U/V/W	kg	2240	2630	2910	2980	3120	3160	3360
L	P	Z	kg	2440	2630	2910	2980	3120	3160	3360

Aermec reserves the right to make any modifications deemed necessary. All data is subject to change without notice. Aermec does not assume responsibility or liability for errors or omissions.

Aermec S.p.A.
Via Roma, 996 - 37040 Bevilacqua (VR) - Italia
Tel. 0442633111 - Telefax 044293577
www.aermec.com