

DESIGN & INSTALLATION

Ceiling

MODULAR CEILING
COOLING AND HEATING

ModularCeiling



VBOOK4_EN | 11/2025

PDF



www.variotherm.com

VARIOTHERM



3

5.4

5.2

5.6



INSTALLATION VIDEO

The installation video is no substitute for this planning and installation instructions!

1	PRINCIPLES	4	3	SUBSTRUCTURE	10
1.1	Cooling	4	3.1	General	10
1.2	Heating	6	3.2	Spacing in the edge area	10
1.3	Energy saving	6	3.3	Basic battens/profiles (standard)	10
1.4	Design freedom	6	3.4	Support battens/profiles (without basic battens)	11
1.5	Description and advantages of ModularCeiling	7	3.5	Support battens directly attached (without basic battens)	12
2	PRECONDITIONS	8	3.6	Movement joints	12
2.1	Warranty conditions	8	3.7	Insulation in substructure	12
2.2	Standards information	8	4	FIRE PROTECTION	13
2.3	Fire protection	8	5	COMPONENTS & PROCESSING	14
2.4	Ceiling loads	8	5.1	ModularPanels / ModularBlankPanels – Overview	14
2.5	Goods transport/storage	8	5.2	ModularPanels / ModularBlankPanels – Installation	18
2.6	Tools	9	5.3	VarioModular pipes	24
2.7	Visible side/rear side of the ModularPanel	9	5.4	Press-fit couplings / press tools	25
2.8	Humidity	9	5.5	Dew-point monitoring/sensor DPS	27
2.9	Maximum flow temperature and dew point	9	5.6	VarioManifold	27
2.10	Other work documents	9			

*This is how
it's done ...*



6	FINISHED SURFACE	28		
	6.1 Filling.....	28		
	6.2 Painting.....	28		
	6.3 Load attachment of the ModularCeiling	28		
7	ACOUSTICS	29		
8	HEATING/COOLING PRACTICE	30		
	8.1 Calculation of the heating and cooling load.....	30		
	8.2 Variotherm Dimensioning software	30		
	8.3 Cooling capacity and dew point.....	31		
	8.4 Heat emission.....	31		
	8.5 Pressure loss.....	32		
	8.6 Arrangement of the cooling/heating surfaces.....	33		
9	PROTOCOLS	34		
	9.1 Leak-tightness test (in accordance with EN 1264-4).....	34		
	9.2 Functional heating (in compliance with EN 1264-4 or BVF) ..	35		
	9.3 Commissioning.....	35		

1 PRINCIPLES

For perfect comfort and optimum energy savings, Variotherm recommends a combination of floor, wall and ceiling heating/cooling system.

For hot summer days, we recommend wall and/or ceiling cooling. Instead of hot water, cool water flows through the pipes at a temperature of 16-20 °C. Rooms are cooled to a comfortable temperature – without draughts and no noise whatsoever.

In general, walls offer the largest exchange area, which is why wall heating systems ensure that people can easily feel the radiant heat.

1.1 Cooling

Comfort is not only created by a specific air temperature in the room. Equally important is the temperature of all surfaces enclosing the room. The physiologically perceived temperature corresponds approximately to the arithmetic mean of the two.

When does a person feel comfortable?

A person only feels comfortable when the basic equation of "thermal comfort" is fulfilled:

$$\text{heat generation} = \text{heat emission}$$

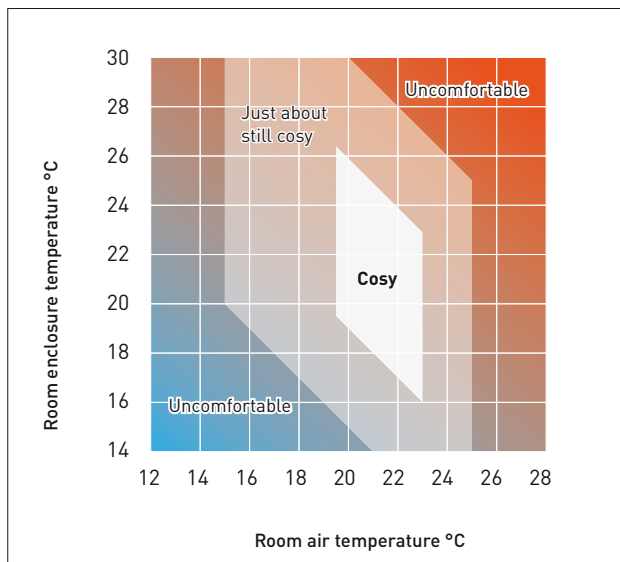

▲ Zone of cosiness

	Heating	Cooling
Ceiling	++	+++
Wall	+++	+++
Floor	++	+

▲ Which system areas are suitable for which needs?

Heat production = heat loss

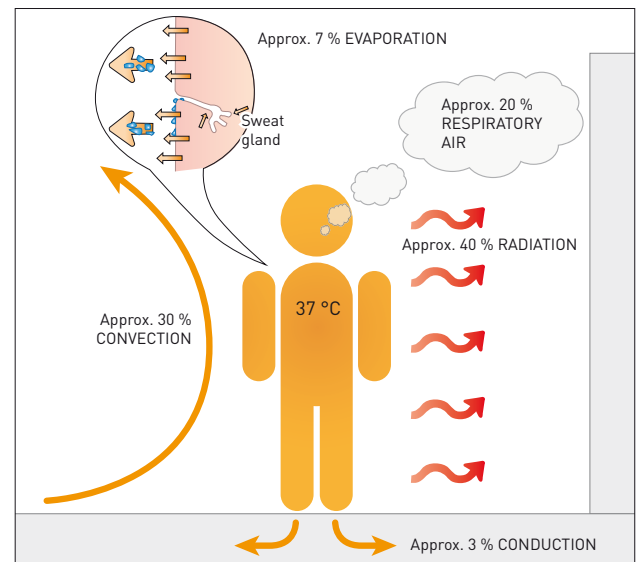

▲ Human heat balance

Cooling via ceiling surfaces offers the advantage of a gentle radiant exchange between the cooled ceiling surface and the human body. But other warmer objects in the room (floor, interior walls, furnishings, etc.) also give off heat to this cooled surface, because radiation always travels from the warmer to the colder object. This heat extraction leads to a reduction in the surface temperature of these objects and thus to a cooling effect. The room air is also reduced to a comfortable level.

The ModularCeiling generates neither unpleasant draughts nor noise, which is often perceived as annoying with conventional air conditioning systems.

Based on experience, cooling makes sense at a room temperature ≥ 26 °C. To achieve a noticeable effect and suitably cool the body, a reduction of the wall surface temperature to approx. 19–22 °C is recommended.

Economic efficiency

The required cooling capacity can be better distributed via the medium of water than via air. The pump costs incurred during operation are usually lower than the costs for ventilators. Even a 100 % coverage of the cooling load in accordance with VDI 2078 (calculation of the cooling load of air-conditioned rooms) is possible in low-energy buildings with sunshades and few internal loads.

One of the greatest advantages of ceiling cooling/ceiling heating systems are the low additional investment costs. One and the same system is used for cooling and heating: The same ceiling area, the same pipe system and the same heating/cooling manifold with supply pipes and circulation pump. Refrigeration (refrigeration machine/ heat pump/ cold from the ground and groundwater) is planned parallel to the heating unit. Many modern heat pumps of modern can already be switched from heating to cooling - without any great additional costs. However, ambient coldness (deep drilling, surface collectors, wells, etc.) can also be used as a cooling source - at zero cost, so to speak.

Combination of displacement ventilation and surface cooling

Where dehumidification and ventilation are concerned, surface cooling does not replace an air-conditioning system. Displacement ventilation is an air-conditioning system with low air exhaust speeds and laminar flow of the expelled air at the exhaust vents. Low turbulence in the air flow through the room is achieved through the type of ducting in the room, blowing of air at floor level at

a slightly subnormal temperature and extraction of the exhaust air at the ceiling level. This type of displacement flow, known as "displacement ventilation" can achieve almost complete elimination of draughts. Combining a ceiling cooling and a displacement ventilation system means considerably higher cooling capacities can be achieved than would be the case with the displacement ventilation system alone, without exceeding the thermally comfortable air velocities. If the supplied air is dehumidified, low ceiling surface temperatures and thus high radiant cooling capacity can be achieved without condensation, even on humid days.

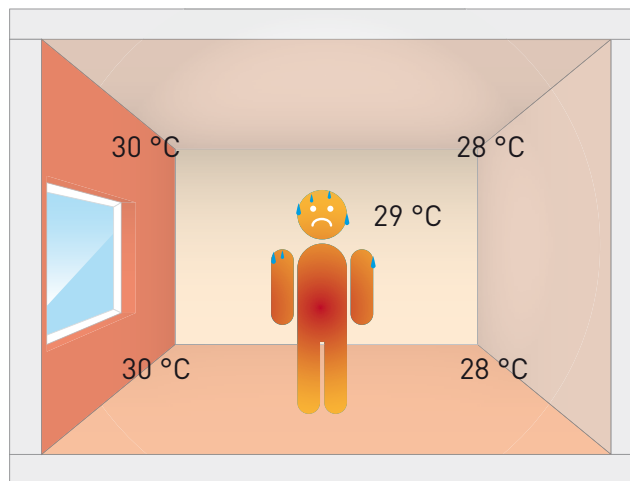

▲ Discomfort without cooling

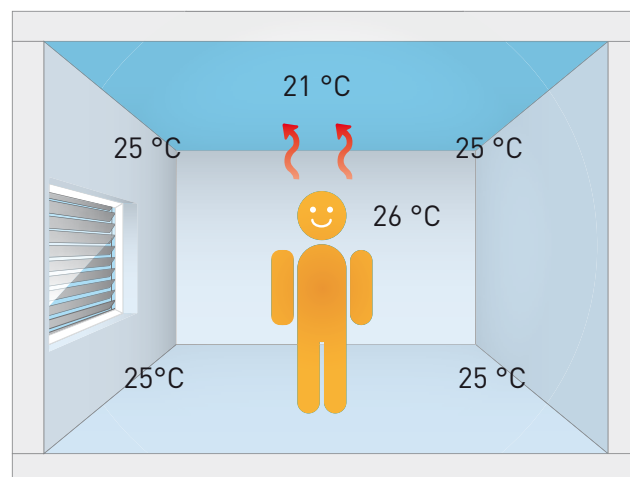

▲ Comfort with ceiling cooling

1.2 Heating

The ModularCeiling is not only suitable for cooling, but can also be used for heating. Compared to other heating systems, the feeling of comfort is significantly increased with the ModularCeiling heating systems. You can set the room temperature lower than you would with convection heating, since radiant heat from the ModularCeiling raises the perceived air temperature.

It is important that the heat emitted by the human body can be emitted to all sides as evenly as possible. If too much heat is extracted (e.g. cold surfaces, draughts) from one side or if the heat transfer is obstructed on one side (hot surfaces or vapour-tight, thick clothing), we experience this as unpleasant.

The lower the air temperature in the room, the warmer the enclosing surfaces (wall surfaces, floors, ceilings, but also windows) have to be to make it cosy.

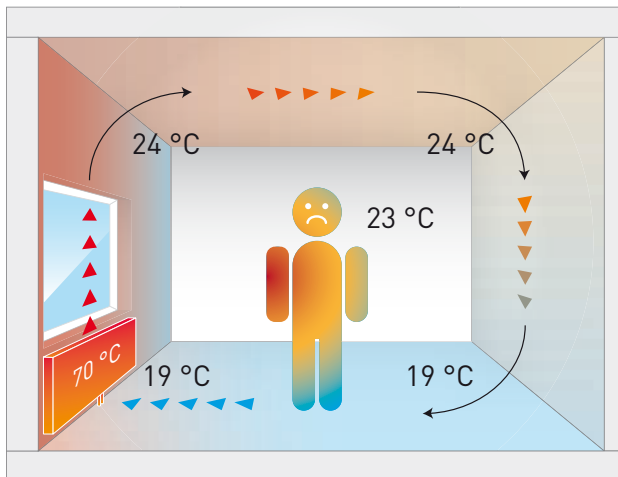

▲ Discomfort with radiators

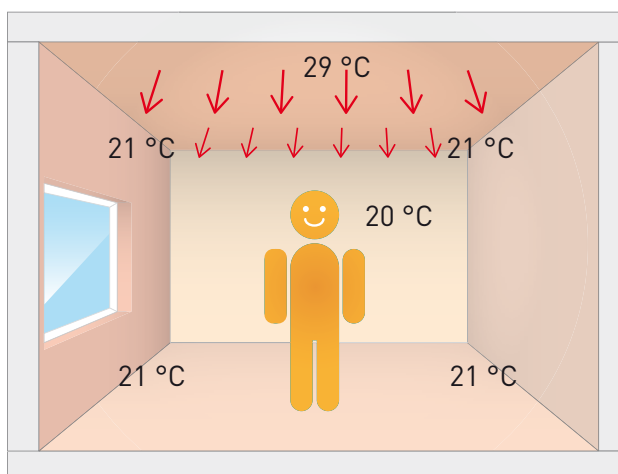

▲ Comfort with ceiling heating

Advantages ModularCeiling

- › Cooling, heating and a ready-to-install ceiling all in one
- › Available with acoustic function on request: With Variotherm the holes of the acoustic panels are not covered by cooling/heating elements! This is the only way to ensure certified, guaranteed noise reduction.
- › Ideal for timber frame construction, prefabricated house construction, attics and refurbishment
- › As cooling: silent, no draughts, saves energy
- › As heating: large-surface, extremely energy-saving low-temperature system
- › Totally flexible panel system for all constructional requirements
- › Building biology tested gypsum fibre boards and components
- › Fire resistance certification for ModularCeiling-Classic

1.3 Energy saving

Energy losses are significantly reduced while comfort is increased thanks to the optimised room air temperature. It is roughly estimated that approx. 6 % of heating costs are saved per 1 °C reduction in room air temperature during heating or per 1 °C increase in room air temperature during cooling. This has the additional physiological advantage, that for most people the body's oxygen intake is increased.

The ModularCeiling is ideal for use with low-temperature energy sources such as condensing boilers, heat pumps and solar collectors, as it operates with a low surface and heating medium temperature.

This means that energy savings of up to 30 % can be achieved with the Variotherm ModularCeiling compared to conventional heating systems.

1.4 Design freedom

Due to the invisible cooling/heating ceiling, radiators or split-design units can be dispensed with during planning. This saves a lot of space and the interior can be designed freely: No restrictions on the wall and window layout or interior design. Only the ceiling lights and spots have to be taken into account.

1.5 Description and advantages of ModularCeiling

The Variotherm ModularCeiling is an extremely energy-saving cooling and heating system. As a flexible panel system it comes ready to be mounted on ceilings and pitched roofs. Cooling, heating and a ready-to-install ceiling are perfectly combined here in one solution! The desired room climate is achieved by means of hot and cold water circulation - so you can feel really comfortable all year round!

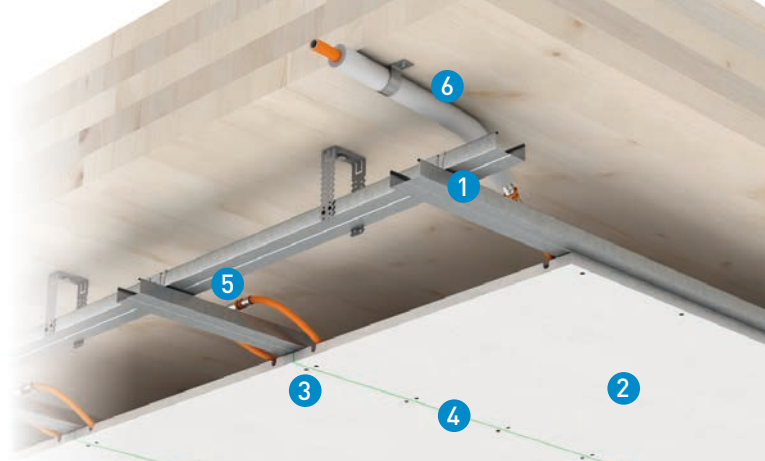

- 1 On-site prepared substructure (wood or metal)
 - 2 ModularPanel
- 3 Dry wall screws
 - 4 Greenline joint adhesive
 - 5 Press-fit coupling
 - 6 Pre-insulated VarioModular pipe 16x2



ModularCeiling-Class
for screwed ceiling constructions
Flexible panel system,
Fire resistance certification



ModularCeiling-Acoustic
for screwed ceiling construction
ModularPanels with noise-absorbing surface

2 PRECONDITIONS

2.1 Warranty conditions

If installed or commissioned incorrectly, all claims on the basis of the manufacturer's warranty and guarantee become void.

This brochure (version dated 11/2025) is intended for authorised qualified personnel and constitutes part of our warranty!

All previous versions become invalid upon release of a new version! For the latest version please refer to the QR Code on the title page or www.variotherm.com.

Local, geographic and climatic regulations/standards for cooling, heating and electrical installations must be observed!

2.2 Standards information

The validity of the standards indicated in these installation instructions was last verified on 6/10/2025! Changes to standards must be checked if necessary!

2.3 Fire protection

With respect to fire protection, the Variotherm ModularPanels 18 mm with integrated VarioModular pipes are equivalent to a 12.5 mm FERMACELL gypsum fibre board without pipes (Test IBS-Linz No. VFA2001-0389.01, fire protection assessment file number 10111710).

Please observe the relevant FERMACELL regulation and FERMACELL fire protection assessments. The Variotherm acoustic ModularPanels provide no fire protection! See also Chapter 4.

2.4 Ceiling loads

Small single "static" loads up to 2 kg (max. 6 kg/m²) can be attached directly to the ModularPanel (see Chapter 6.3) Heavier suspended elements must only be attached to the substructure and not to the ModularPanels. When installing the substructure these loads must be taken into account (see Chapter 3).

2.5 Goods transport/storage

Pre-insulated VarioModular pipes

Leave the VarioModular pipes in the box as long as possible to avoid damage from dents and scratches. Damage of this kind has a detrimental effect on the creep behaviour.

The VarioModular pipes can be damaged by both atmospheric oxygen and UV rays and must not be stored outdoors.

At low temperatures (≤ 5 °C), the VarioModular pipe should be stored in heated rooms prior to processing.

VarioModular 11.6x1.5 pipe

The VarioModular pipe is completely integrated in the ModularPanel.

To prevent the integrated VarioModular pipes being damaged during the construction phase by drilling or breaking work, clearly-visible warning labels must be affixed at appropriate points. Download in Infocenter at www.variotherm.com.

In terms of weather resistance, the same instructions apply to the VarioModular 11.6x1.5 pipe as to the pre-insulated VarioModular 16x2 pipe.

ModularPanels

The ModularPanels are delivered on pallets. When storing, observe the load-bearing capacity of the storage location. The ModularPanels weigh 20.5 kg/m² and should always be stored flat on a level surface. If they are re-stacked during transport on the building site, the visible sides of the ModularPanels should be laid so that they face downwards.

They must be protected from moisture, especially rain. Panels that have become damp for a short time may only be handled after they have completely dried out. Storing the panels vertically leads to deformation and damage to the edges. Transporting the panels horizontally within the building is possible using a pallet truck or other panel transport vehicle.

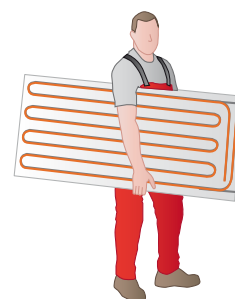
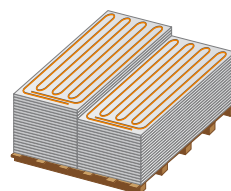

▲ Individual ModularPanels are best carried upright

2.6 Tools

Recommended tools (on site):

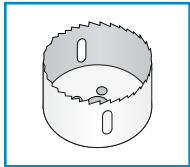

Hole saw

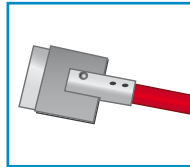

Adhesive scraper

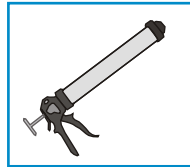

Cartridge gun

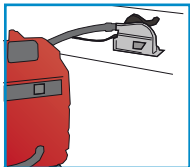

Circular saw or jigsaw

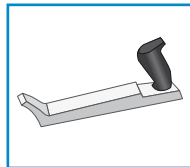

Plane for visible edges

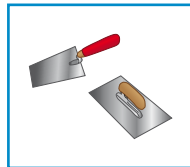

Trowel & plastering knife



Ceiling support



Panel lifter



Clean bucket



Power screw gun, preferably with depth stop

Variotherm tools for connecting Variotherm pipes:

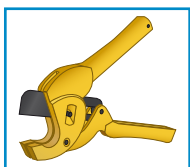

Pipe cutting pliers

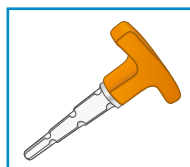

Calibration and chamfering tool

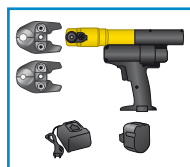

Pressing tools

2.7 Visible side/rear side of the ModularPanel

The visible side of the ModularPanel (= smooth side) faces into the room, the rear side (with the integrated VarioModular pipe) faces the substructure.

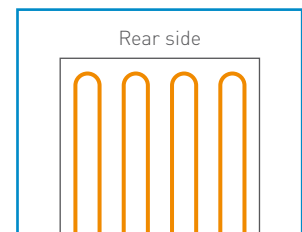
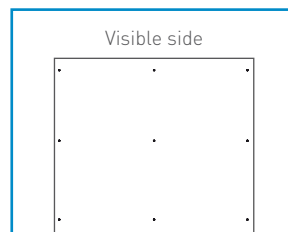

2.8 Humidity

The relative humidity must not exceed 70 % during storage, installation and additional processing of the ModularPanels and during the construction phase and normal use of the building. Wet plaster and wet screeds must be applied and have dried before the ModularPanels are installed.

The ModularPanels may be used in rooms up to humidity class W3 in accordance with ÖN B 3407 (or W1-I in accordance with DIN 18534-1).

2.9 Maximum flow temperature and dew point

Heating: The maximum flow temperature of the ModularPanels is 50 °C. For reasons of comfort $t_{mH} = 35$ °C ($t_f/t_r = 40/30$ °C) should not be exceeded for the ModularCeiling.

Cooling: The flow temperature must be selected in such a way or it must be ensured that the surface temperature of the ModularPanel (room-side and cavity) and the pipe never reaches or falls below the dew-point temperature at any point. Condensation can form on the pipes and surfaces if the flow temperature selected is too low.

Control measures must be taken to prevent this (e.g. dew-point monitor, see Chapter 5.5).

2.10 Other work documents

Please also observe the latest FERMACELL planning and installation instructions! www.fermacell.com

3 SUBSTRUCTURE

3.1 General

Depending on the requirements, substructures are made of timber studs or metal profiles, with or without surface planking or cavity insulation or vapour retarders (vapour barriers). Please observe the instructions of the timber construction or the dry construction system manufacturers for the planning and installation of your ceiling construction.

- › In the case of wooden substructures, the timber used must be sufficiently dry and straight and must comply with ÖNORM EN 338 (grading class C24)
- › In the case of metal substructures, the profiles must be made of soft, non-alloyed steel with double-sided galvanising of at least 100 g/m² according to the ÖNORM DIN 18182-1
- › The substructure must be designed to carry the weight of the ModularPanels (20.5 kg/m²) and any eventual additional loads (e.g. ceiling lights). Additional loads such as ceiling lights, multi-layer planking and other fittings must be taken into account separately! See also Chapter 6.3.
- › Do not glue the ModularPanels directly to the ceiling (plaster)

3.2 Spacing in the edge area

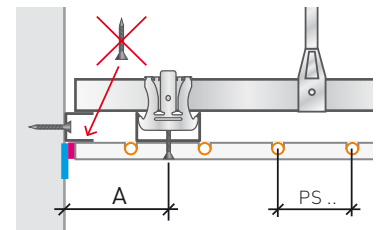
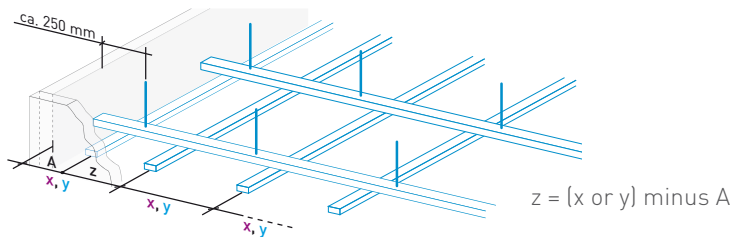

A = 85 mm at PS 75 mm, resp.
A = 105 mm at PS 105 mm.
PS ... Pipe Spacing
Separating layer (tape) ■
Grouted joint (approx. 7 mm) ■

3.3 Basic battens/profiles (standard)

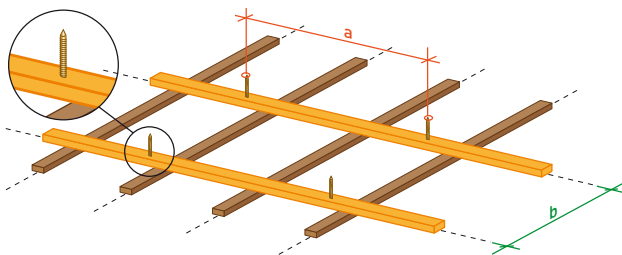

WOODEN SUBSTRUCTURE:
DIRECTLY FASTENED
MAIN JOISTS

	Joist dimensions w × h [mm]	Max. permissible span for loads of up to 30 kg/m ² ≙ ModularPanel (20.5 kg/m ²) + light additional load (up to 9.5 kg/m ²)	Max. permissible span for loads of up to 50 kg/m ² ≙ ModularPanel (20.5 kg/m ²) + heavy additional load (up to 29.5 kg/m ²)
Max. clearance direct attachment (a)	Main joists 48 × 24	650 mm	600 mm
	Main joists 50 × 30	750 mm	600 mm
	Main joists 60 × 40	850 mm	700 mm
Max. axis clearance main joists (b)	Cross joists 48 × 24	600 mm	500 mm
	Cross joists 50 × 30	750 mm	600 mm
	Cross joists 60 × 40	1000 mm	900 mm

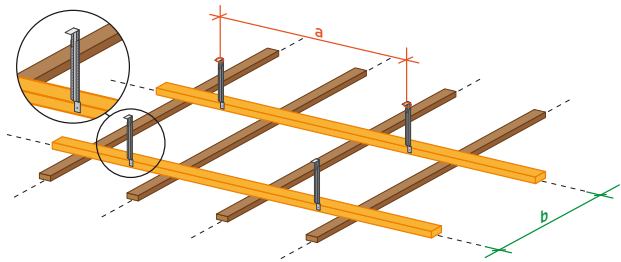

WOODEN SUBSTRUCTURE: SUSPENDED MAIN JOISTS

	Joist dimensions w × h [mm]	Max. permissible span for loads of up to 30 kg/m ² ± ModularPanel (20.5 kg/m ²) + light additional load (up to 9.5 kg/m ²)	Max. permissible span for loads of up to 50 kg/m ² ± ModularPanel (20.5 kg/m ²) + heavy additional load (up to 29.5 kg/m ²)
Max. clearance direct attachment (a)	Main joists 30 × 50*	850 mm	700 mm
	Main joists 40 × 60	1000 mm	850 mm
Max. axis clearance main joists (b)	Cross joists 48 × 24	600 mm	500 mm
	Cross joists 50 × 30	750 mm	600 mm
	Cross joists 60 × 40	1000 mm	900 mm

* Only in conjunction with cross joists that are 50 mm wide and 30 mm high

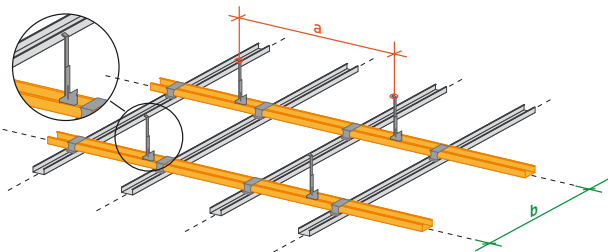

METAL SUBSTRUCTURE: SUSPENDED MAIN PROFILE

	Profile dimensions** [mm]	Max. permissible span for loads of up to 30 kg/m ² ± ModularPanel (20.5 kg/m ²) + light additional load (up to 9.5 kg/m ²)	Max. permissible span for loads of up to 50 kg/m ² ± ModularPanel (20.5 kg/m ²) + heavy additional load (up to 29.5 kg/m ²)
Max. clearance suspension element (a)	Main profile CD 60 × 27 × 06	750 mm	600 mm
Max. axis clearance base profile (b)	Cross profile CD 60 × 27 × 06	1000 mm	750 mm

** Standard steel sheet profiles (as per ÖNORM/DIN 18182 or ÖNORM/DIN EN 14195)

3.4 Support battens/profiles (without basic battens)

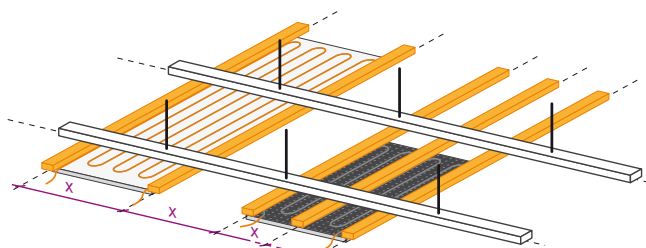

▲ Cross joists **longitudinal** to the ModularPanels

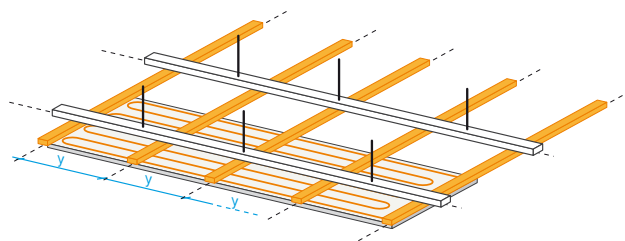

▲ Cross joists **transverse** to the ModularPanels

Panel size w × b [mm]	ModularPanels-Classic									-Acoustic 1000 × 625
	2500 × 625	2500 × 600	2000 × 625	2000 × 600	1500 × 625	1500 × 600	1000 × 625	1000 × 600	2000 × 312	
Max. axis clearance [mm] longitudinal cross joists (x)	625.0	600.0	625.0	600.0	625.0	600.0	625.0	600.0	312.0	312.5
Max. axis clearance [mm] transverse cross joists (y)	416.7	416.7	500.0	500.0	375.0	375.0	500.0	500.0	500.0	500.0

🔥 In the case of fire protection requirements, except where test verification/certification is otherwise specified

3.5 Support battens directly attached (without basic battens)

Due to the lower installation height with simple battens, it is necessary to interrupt the substructure approx. 200 mm after the end of the panel. This is followed by an intermediate space of 200 mm which provides space for supply pipes or press connections. For axis clearance of the supporting battens, see Chapter 3.4.

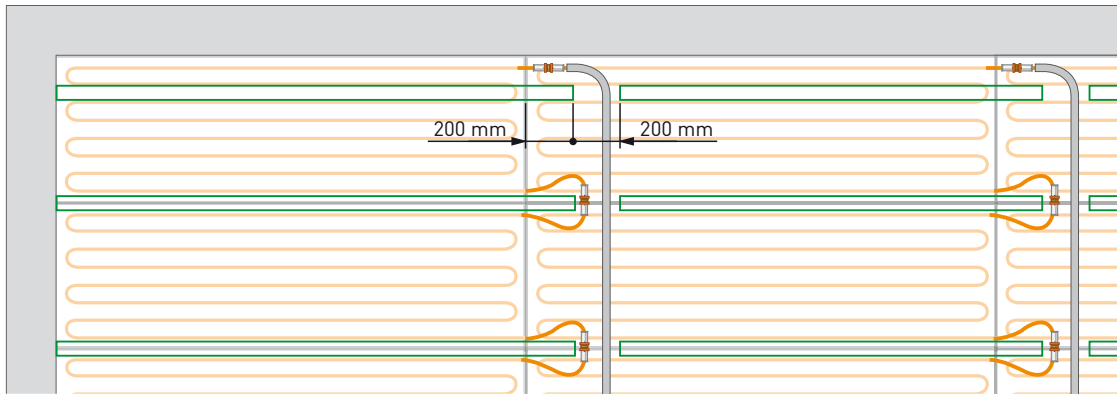

3.6 Movement joints

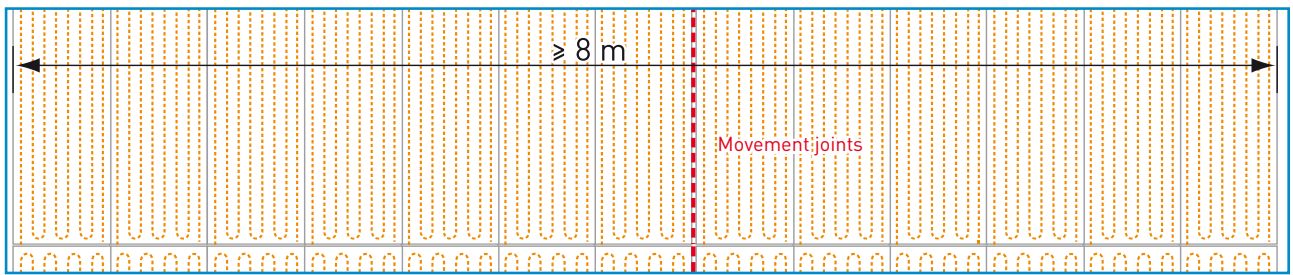

▲ Movement joint at e.g. 13×V020-100 (13×0.625 m = 8.13 m)

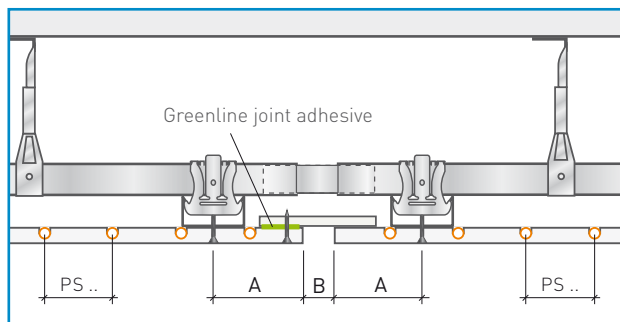

▲ Movement joint with panel strips,
B = movement dimension approx. 10–20 mm

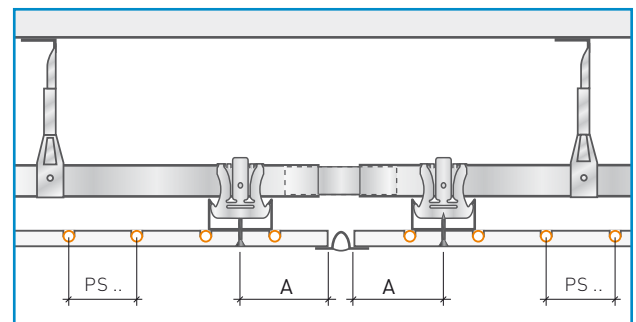

▲ Movement joint with additional profile

A = 85 mm at PS 75 mm, resp. A = 105 mm at PS 105 mm; PS ... Pipe Spacing

3.7 Insulation in substructure

If required, the cavity of the ceiling construction can be equipped with mineral wool. In combination with ModularPanels-Acoustic, the acoustic values can be improved even further (see also chapter 7). Vapour-retarders cannot be installed. Care must be taken to ensure that the dew point is not reached within the mineral wool.

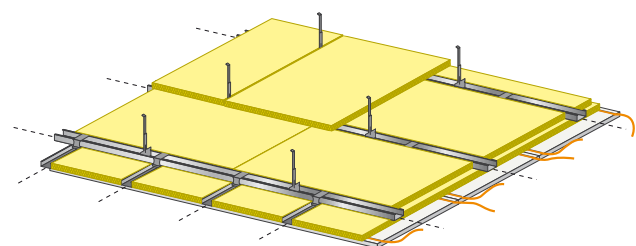

▲ Example of substructure insulation

4 FIRE PROTECTION



The Variotherm ModularPanels 18 mm with integrated VarioModular pipes are equivalent to a 12.5 mm FERMACELL gypsum fibre board without pipes (Test IBS-Linz No. VFA2001-0389.01, fire protection assessment file number 10111710). Please observe the relevant FERMACELL regulation and FERMACELL fire protection assessments. The Variotherm acoustic ModularPanels provide no fire protection! See also Chapter 4.



IBS - INSTITUT FÜR BRANDSCHUTZTECHNIK UND SICHERHEITSFORSCHUNG
 BRANDSCHUTZTECHNIK UND SICHERHEITSFORSCHUNG
 54111 LINZ AUSTRIA

DATE: 17. November 2010
 Aktennummer: 10111710
 Besteller: Dpt. Ing. (FH) U. Stöckl, Heise Gm. 872

Brandschutztechnische Beurteilung, Aktennummer: 10111710
 Brandversuche entsprechend EN 1364, Teil 1 sowie EN 1365, Teil 2 sowohl eines unbelasteten Wandelementes als auch eines tragenden Deckenelementes der Firma Variotherm Heizsysteme GmbH

Aufgrund der in der Prüfstelle IBS Linz durchgeführten Brandprüfungen wird bestätigt, dass sowohl ein unbelastetes Wandelement als auch ein tragendes Deckenelement der Firma Variotherm Heizsysteme GmbH die Prüfbedingungen entsprechend EN 1364 Teil 1 sowie EN 1365, Teil 2 erfüllen.

Die Variotherm Modulplatten bestehend aus einer 18 mm Fercacell-Platte mit eingeklebt Mehrschichtverbundrohr 11,8 x 1,5/Alu 0,20 mm wurden zwei Brandprüfungen unterzogen:

- 1.) Brandversuch einer nichttragenden Wand nach EN 1363-1 und EN 1364-1
 Prüfbericht Nr.: 10050617
 Prüfdatum: 31.08.2010
 Prüfdauer: 45 Minuten und 20 Sekunden
 Nach EN 13501-2 Kapitel 7.5.2 in die Feuerwiderstandsklasse EI 45 einzustufen
 Der Brandversuch vom 31.08.2010 am IBS Linz wurde dem Versuch mit der Prüfbericht Nr.: PG10934 vom 12.04.2002 am Danish Institute of Fire and Security Technology nachgestellt, bei dem eine Versuchszeit von 35 Minuten erreicht wurde.
- 2.) Brandversuch eines tragenden Deckenelementes nach EN 1363-1 und EN 1365-2
 Prüfbericht Nr.: 10050618
 Prüfdatum: 28.09.2010

IBS - INSTITUT FÜR BRANDSCHUTZTECHNIK UND SICHERHEITSFORSCHUNG GESELLSCHAFT M.B.H.
 Accredited testing and inspection body

VARIO THERM
 HEIZUNG, KÜHLUNG, WERKSTÄTTE

English Translation according to „Brandschutztechnische Beurteilung“:

Fire safety assessment, file number: 10111710
Fire tests in accordance with EN 1364, Part 1 as well as EN 1365, Part 2 on an unloaded wall element as well as on a load-bearing ceiling element of the company Variotherm Heizsysteme GmbH

On the basis of the fire tests carried out at the testing body IBS Linz, we hereby certify that both an unloaded wall element as well as a load-bearing ceiling element from the company Variotherm Heizsysteme GmbH satisfy the test requirements in accordance with EN 1364, Part 1 as well as EN 1365, Part 2.

The Variotherm modular panels, consisting of an 18 mm Fercacell panel with inserted multi-layer composite pipe 11.6 x 1.5/Alu 0.20 mm, were subjected to two fire tests:

- 1.) Fire test on a non-load-bearing wall as per EN 1363-1 and EN 1364-1
 Test report no.: 10050617
 Test date: 31/08/2010
 Test duration: 45 minutes and 20 seconds
 In accordance with EN 13501-2 Section 7.5.2 to be classified under the fire resistance category EI 45
 The fire test dated 31/08/2010 at the IBS Linz was a reconstruction of the trial as per test report no.: PG10934 dated 12/04/2002 at the Danish Institute of Fire and Security Technology in which a trial duration of 35 minutes was achieved.
- 2.) Fire test on a load-bearing ceiling element as per EN 1363-1 and EN 1365-2
 Test report no.: 10050618
 Test date: 28/09/2010
 Test duration: 100 minutes and 20 seconds
 In accordance with EN 13501-2 Section 7.3.3 to be classified under the fire resistance category REI 90
 The fire test dated 28/09/2010 at the IBS Linz was a reconstruction of the trial as per test report no.: MA39-VFA 2002-2173.01 dated 14/04/2003 at the Municipal Department 39 of the Research and Testing Institute of the City of Vienna in which a trial duration of 94 minutes was achieved.

Fire safety assessment

The fire tests carried out at the IBS were identical in terms of their structure to the fire tests carried out at the above mentioned testing institutes, with the difference that the 12.5 mm thick Fercacell panels facing the fire were replaced by 18 mm thick Variotherm modular panels.

On the basis of the test results available as per ÖNORM EN 1364, Part 1 as well as ÖNORM EN 1365, Part 2, it can be ascertained that at least identical results were achieved with the 18 mm thick Variotherm modular panels as with the 12.5 mm thick Fercacell panels, meaning that there is direct comparability.

It can therefore be confirmed that, in lightweight constructions (walls, ceilings, pitched roofs), the normal 12.5 mm thick Fercacell panels can be replaced by 18 mm thick Variotherm modular panels without disadvantages in terms of the fire resistance.

IBS - INSTITUT FÜR BRANDSCHUTZTECHNIK UND SICHERHEITSFORSCHUNG GESELLSCHAFT M.B.H.
 Accredited testing and inspection body

Examples of fire protection structures

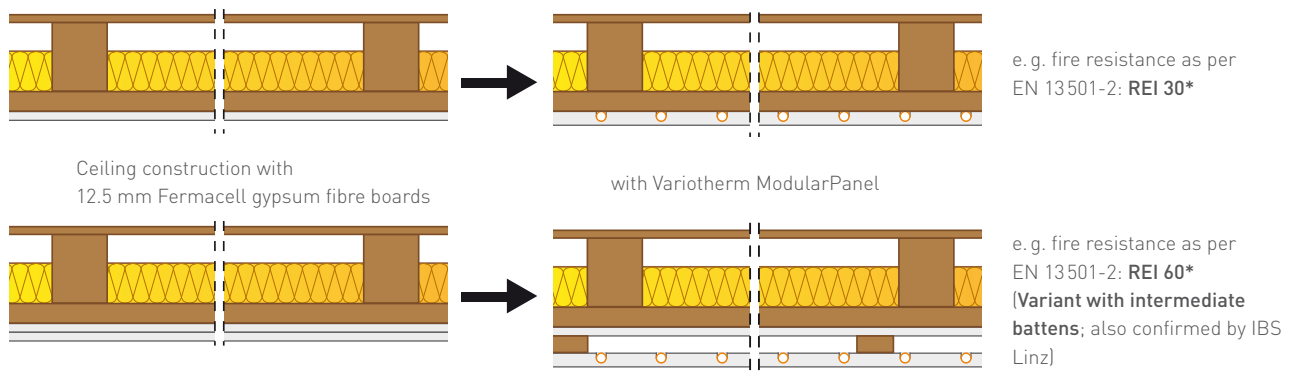

* For details regarding wall fittings, please refer to the Fercacell planning documents.

5 COMPONENTS & PROCESSING

5.1 ModularPanels / ModularBlankPanels – Overview

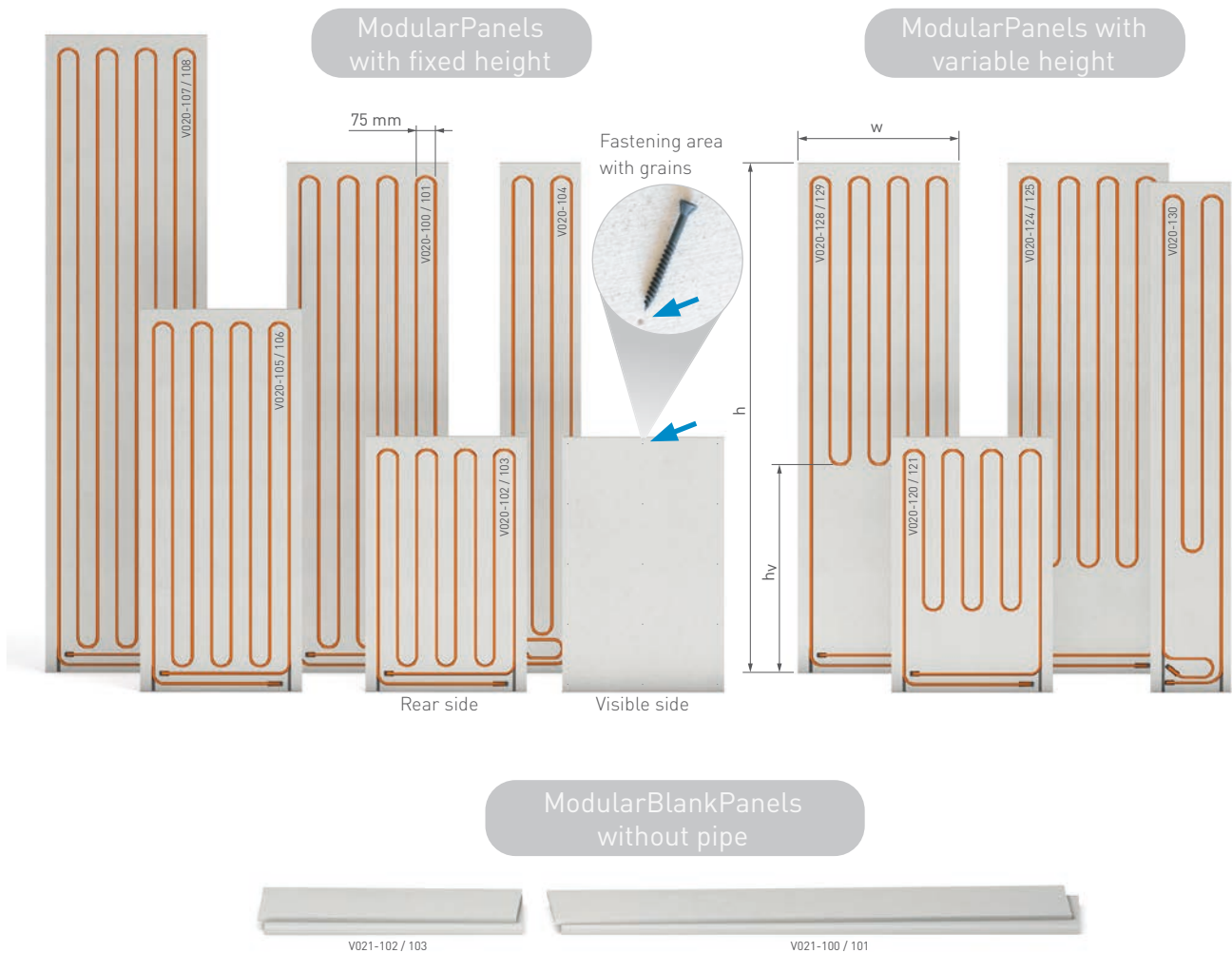

The ModularPanels are 18 mm thick, environmentally safe-tested gypsum fibreboards. They consist of gypsum, cellulose and water, all of which are natural resources. Cellulose is manufactured from 100 % waste paper. Different mixtures (types of paper, cardboard) are

created, depending on the paper collected in the local region. This can lead to differences in board colour. The VarioModular 11.6x1.5 pipes are already integrated in the back of the panels. The axis clearance of the pipes is 75 or 105 mm

Panel technical data:

Panel: Building biology tested gypsum fibre board

Fire resistance as per EN 13501-1:

non-flammable, A2-s1,d0

Identification as per EN 15283-2:

GF-I-W2-C1

Thermal conductivity λ : 0.32 W/mK

Apparent density ρ_K : 1150 \pm 50 kg/m³

Water vapour diffusion

resistance factor μ : 13



eco
INSTITUT

Panels with either fixed or variable height are available:

Fixed height: The entire surface of the ModularPanel is laid with pipes and serves as a heating/cooling surface.

Variable height: Only part of the panel is laid with pipes and serves as a heating/cooling surface. The unused area (hv) can be cut to size individually or, for example, be used for recessed lights.

Special solutions
(on request)

ModularPanels with
fixed height
(pipe spacing 105 mm)

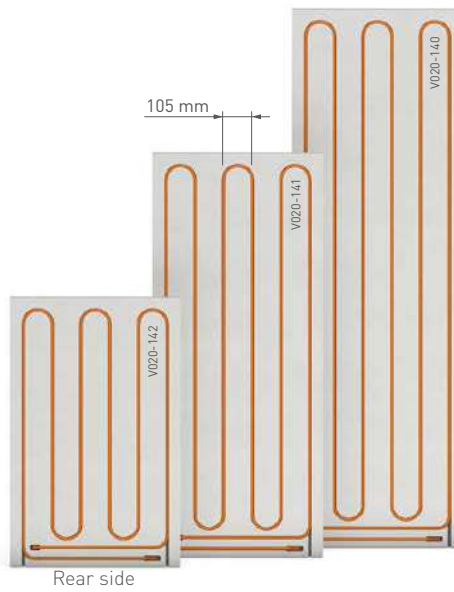

<< Large pipe spacing
Ideal for light spots up to
mounting diameter \varnothing 80 mm

ModularPanels with
acoustic function



ModularPanels-Acoustic
3 different hole patterns.
Noise-absorbing acoustic surface
Rear side covered with acoustic
fleece.
>> Details see Chapter 7.















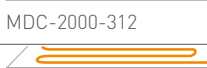



V024-104

V024-300

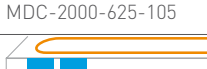
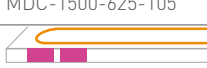
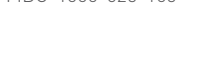

V024-200

Overview of the ModularPanels/ModularBlankPanels

Part no.	Product code / Colour code	Pipe spacing [mm]	Dimensions (h × w), [mm]	Height h _v [mm]	Panel surface [m ²]	Effective surface [m ²]	Laid pipe in panel	Weight/ panel	Required quantity ¹ dry wall screws 3.9 × 40 mm				
									Longitudinal joists	Transverse joists			
ModularPanels-Classic											🔥		🔥
V020-100	 MDC-2000-625	75	2000 × 625	-	1.25	1.25	16.2 m	25.5 kg	2 × 9 pcs.	3 × 11 pcs.	5 × 5 pcs.	6 × 5 pcs.	
V020-101	 MDC-2000-600	75	2000 × 600	-	1.20	1.20	16.2 m	24.5 kg					
V020-102	 MDC-1000-625	75	1000 × 625	-	0.63	0.63	8.2 m	12.8 kg	2 × 5 pcs.	3 × 6 pcs.	3 × 3 pcs.	4 × 5 pcs.	
V020-103	 MDC-1000-600	75	1000 × 600	-	0.60	0.60	8.2 m	12.2 kg					
V020-104	 MDC-2000-312	75	2000 × 312	-	0.62	0.62	8.2 m	12.6 kg	2 × 9 pcs.	2 × 11 pcs.	5 × 2 pcs.	6 × 3 pcs.	
V020-105	 MDC-1500-625	75	1500 × 625	-	0.94	0.94	12.2 m	19.2 kg	2 × 7 pcs.	3 × 9 pcs.	5 × 3 pcs.	5 × 5 pcs.	
V020-106	 MDC-1500-600	75	1500 × 600	-	0.90	0.90	12.2 m	18.4 kg					
V020-107	 MDC-2500-625	75	2500 × 625	-	1.56	1.56	20.2 m	33.8 kg	2 × 11 pcs.	3 × 14 pcs.	7 × 3 pcs.	7 × 5 pcs.	
V020-108	 MDC-2500-600	75	2500 × 600	-	1.50	1.50	20.2 m	30.6 kg					
V020-120	 MDC-1000-625-V300	75	1000 × 625	300	0.63	0.48	6.7 m	13.0 kg	2 × 5 pcs.	3 × 6 pcs.	3 × 3 pcs.	4 × 5 pcs.	
V020-121	 MDC-1000-600-V300	75	1000 × 600	300	0.60	0.46	6.7 m	12.5 kg					
V020-124	 MDC-2000-625-V400	75	2000 × 625	400	1.25	1.04	14.2 m	25.8 kg	2 × 9 pcs.	3 × 11 pcs.	5 × 5 pcs.	6 × 5 pcs.	
V020-125	 MDC-2000-600-V400	75	2000 × 600	400	1.20	1.00	14.2 m	24.8 kg					
V020-128	 MDC-2000-625-V800	75	2000 × 625	800	1.25	0.79	11.8 m	26.2 kg	2 × 9 pcs.	3 × 11 pcs.	5 × 5 pcs.	6 × 5 pcs.	
V020-129	 MDC-2000-600-V800	75	2000 × 600	800	1.20	0.76	11.8 m	25.1 kg					
V020-130	 MDC-2000-312-V500	75	2000 × 312	500	0.62	0.47	6.2 m	12.8 kg	2 × 9 Stk.	2 × 11 Stk.	5 × 2 Stk.	6 × 3 Stk.	
V020-140	 MDC-2000-625-105	105	2000 × 625	-	1.25	1.25	12.3 m	25.6 kg	2 × 9 pcs.	3 × 11 pcs.	5 × 5 pcs.	6 × 5 pcs.	
V020-141	 MDC-1500-625-105	105	1500 × 625	-	0.94	0.94	9.3 m	19.2 kg	2 × 7 pcs.	3 × 9 pcs.	5 × 3 pcs.	5 × 5 pcs.	
V020-142	 MDC-1000-625-105	105	1000 × 625	-	0.63	0.63	6.3 m	12.9 kg	2 × 5 pcs.	3 × 6 pcs.	3 × 3 pcs.	4 × 5 pcs.	

¹ Spread out bolts evenly across the length/width of the panel.



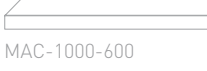

🔥 In the case of fire protection requirements, except where test verification/certification is otherwise specified

Part no.	Product code / Colour code	Pipe spacing [mm]	Dimensions (h × w), [mm]	Height h _v [mm]	Panel surface [m ²]	Effective surface [m ²]	Laid pipe in panel	Weight/ panel	Required quantity ¹ dry wall screws 3.9 × 40 mm				
									Longitudinal joists		Transverse joists		
ModularBlankPanels-Classic											🔥		🔥
V021-100	 MAC-2000-625	–	2000 × 625	–	1.25	without pipe	27.1 kg	2 × 9 pcs.	3 × 11 pcs.	5 × 5 pcs.	6 × 5 pcs.		
V021-101	 MAC-2000-600	–	2000 × 600	–	1.20	without pipe	26.0 kg						
V021-102	 MAC-1000-625	–	1000 × 625	–	0.63	without pipe	13.6 kg	2 × 5 pcs.	3 × 6 pcs.	3 × 3 pcs.	4 × 5 pcs.		
V021-103	 MAC-1000-600	–	1000 × 600	–	0.60	without pipe	13.0 kg						

¹ Spread out bolts evenly across the length/width of the panel.

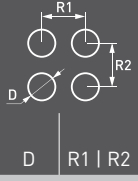
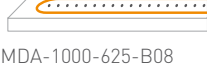
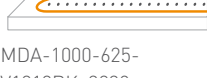
🔥 In the case of fire protection requirements, except where test verification/certification is otherwise specified

Overview of the ModularPanels-Acoustic/ModularBlankPanels-Acoustic

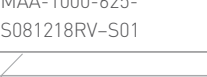
Part no.	Product code / Colour code	Pipe spacing [mm]	Dimensions (h × w), [mm]				Panel surface [m ²]	Effective surface [m ²]	Laid pipe in panel	Weight/ panel	Required quantity ¹ dry wall screws 3.9 × 40 mm			
				D	R1	R2					Longitudinal joists		Transverse joists	
ModularPanels-Acoustic											🔥		🔥	
V024-104	 MDA-1000-625-B08	75	1000 × 625	8	15 16	0.63	0.63	8.5 m	11.5 kg	3 × 5 pcs.	–	3 × 3 pcs.	–	
V024-200	 MDA-1000-625-V1212RK-3239	78	1000 × 625	12	39 32	0.63	0.63	8.7 m	12.0 kg	3 × 5 pcs.	–	3 × 3 pcs.	–	
V024-300	 MDA-1000-625-S081218RV-S01	78	1000 × 625	8 12 18	–	0.63	0.63	8.7 m	12.4 kg	3 × 5 pcs.	–	3 × 3 pcs.	–	
ModularBlankPanels-Acoustic														
V021-108	 MAA-1000-625-B08	–	1000 × 625	8	15 16	0.63	without pipe	11.6 kg	3 × 5 pcs.	–	3 × 3 pcs.	–		
V021-200	 MAA-1000-625-V1212RK-3239	–	1000 × 625	12	39 32	0.63	without pipe	12.1 kg	3 × 5 pcs.	–	3 × 3 pcs.	–		
V021-300	 MAA-1000-625-S081218RV-S01	–	1000 × 625	8 12 18	–	0.63	without pipe	12.5 kg	3 × 5 pcs.	–	3 × 3 pcs.	–		
V021-102	 MAA-1000-625	–	1000 × 625	–	–	0.63	without pipe	13.6 kg	3 × 5 pcs.	–	3 × 3 pcs.	–		

¹ Spread out bolts evenly across the length/width of the panel.

5.2 ModularPanels / ModularBlankPanels – Installation

- > Dry wall screw 3.9 x 40 mm
- > Part No.:
- F120-0250 (PKU: 250 pcs.)
- F120-1000 (PKU: 1000 pcs.)
- > Weight/PKU:
- 0.6 kg (F120-0250)
- 2.4 kg (F120-1000)
- > Consumption: 16 pcs./m²
- > Optimum shank length
- > Incl. associated bit



- > Greenline joint adhesive
- > Part No.: F111
- > PKU: 1 cartridge
- Carton with 25 cartridges
- > Weight/PKU: 550 g
- > Consumption: ~7 m² / cartridge
- > For connecting the blunt adjoining ModularPanels

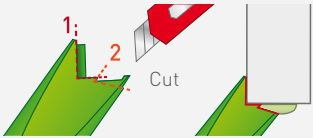

A tip from Variotherm: Cut off the cartridge tip as shown in the illustration.

- > Adhesive tape
- > Part No: V288
- > Weight/PKU: 210 g
- PKU: 1 pce.
- Carton with 36 pcs.
- > As a separating layer to joint surfaces or between the panel contact points and the substructure (if required)



A tip from Variotherm: Use a power screw gun if possible and set the penetration depth of the screw head to approx. 0.1 mm.

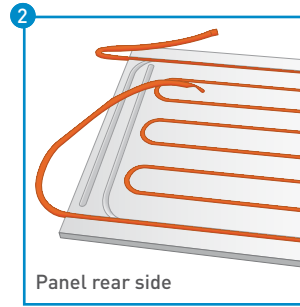
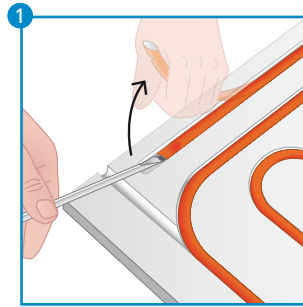

Panel rear side

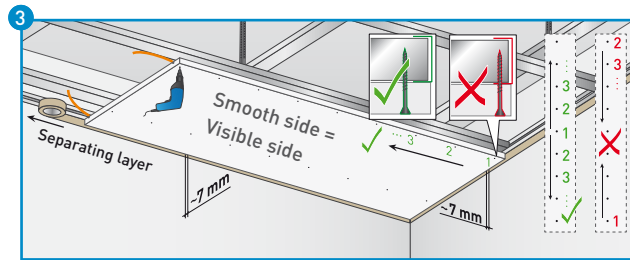

The ModularPanel is installed in the fastening area (see page 20/21) with the 3.9 x 40 mm dry wall screws.

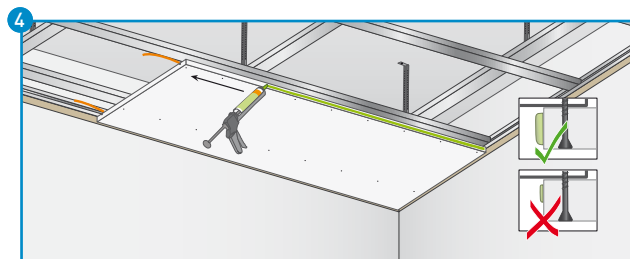

Apply greenline joint adhesive in flat bulge shapes (width around 14 mm) to the well-dusted panel edge. Processing temperature: Adhesive > 10 °C, room temperature > 5 °C.

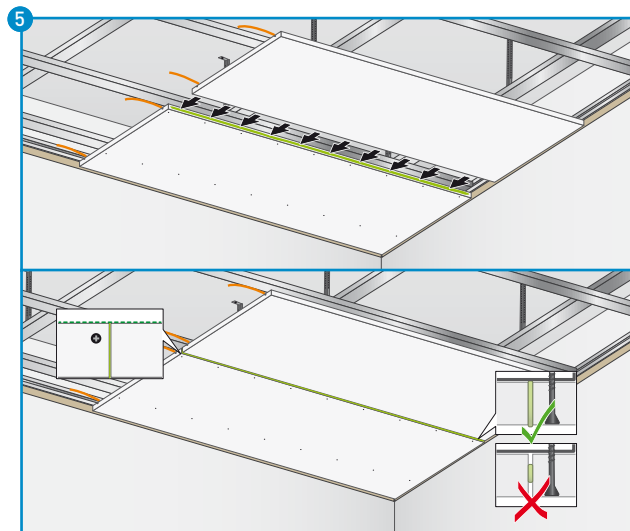

Press the second ModularPanel against the first one so that the joint is tight. The joint width must not exceed 1 mm. Leave the joint adhesive approx. 18 to 36 hours to harden and only afterwards scrape off any excess (see also Chap. 6.1).

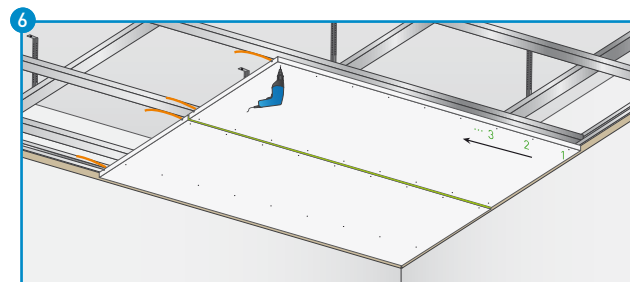

Screw the second ModularPanel in the correct order and repeat with each additional ModularPanel.

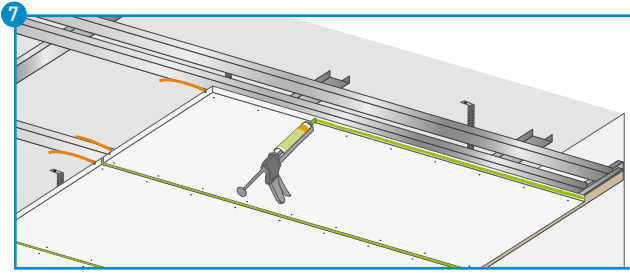

The remaining areas to the side of the ModularPanels are filled with ModularBlankPanels. Mounting is carried out 1:1 as with the ModularPanels.

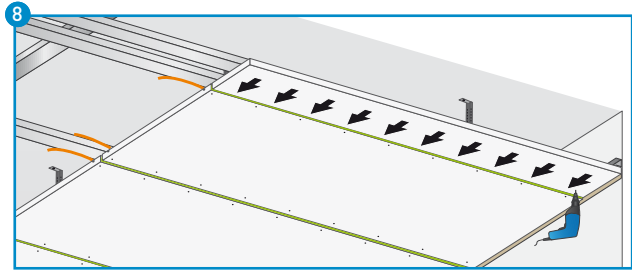

For cut panel edges (handheld circular saw), it should be noted that cut edges must be dusted directly and immediately before the application of the joint adhesive.

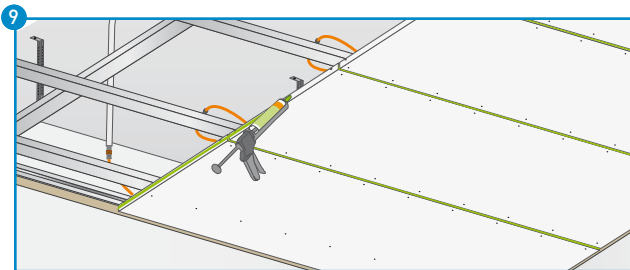

Before starting the next row of panels, the supply pipes or ModularPanels are pressed together (see Chapter 5.4).

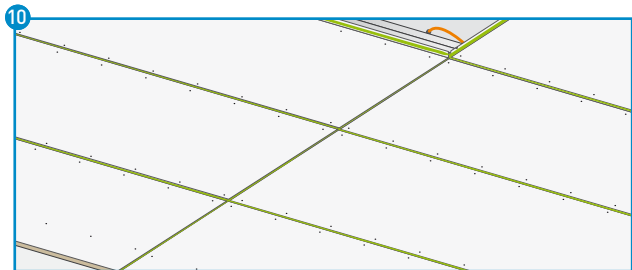

Adapt the ModularPanels

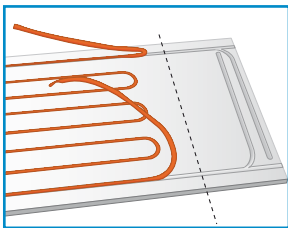

▲ Shorten the variable ModularPanel in length

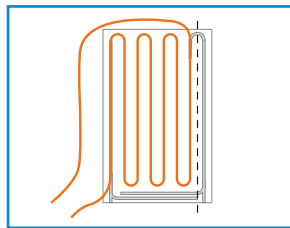

▲ Shorten the Modular-Panels in width

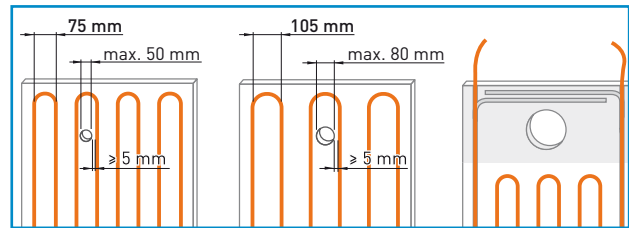

▲ Cut-out for blank piping, light spots, etc.

Transitions to other panel materials

Different materials expand in different ways. Therefore, a ceiling surface should be installed with the same panel material throughout.

Variotherm provides no warranty for transitions to other board materials (for example gypsum plasterboards). Please observe the guidelines of the respective (panel) manufacturers.

As a possibility for transitions, we can provide the following examples from practice:

- › Grouted joints (approx. 7 mm) ■ with a separating layer ■ (= decoupled connection).
Advantage: intentional straight crack (usually hardly visible)
- › Elastic seams (acrylic mass).
(maintenance seam, not permitted for fire-resistant constructions)
- › Fascia
- › Wooden strip fixed on one side for covering the transition

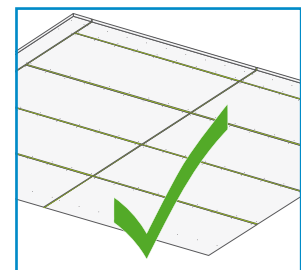

▲ Gypsum fibre boards

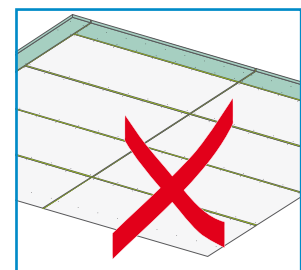

▲ Gypsum fibre boards and Gypsum plasterboards

Fastening area of the ModularPanels - (pipe spacing 75 mm) batten lengthwise

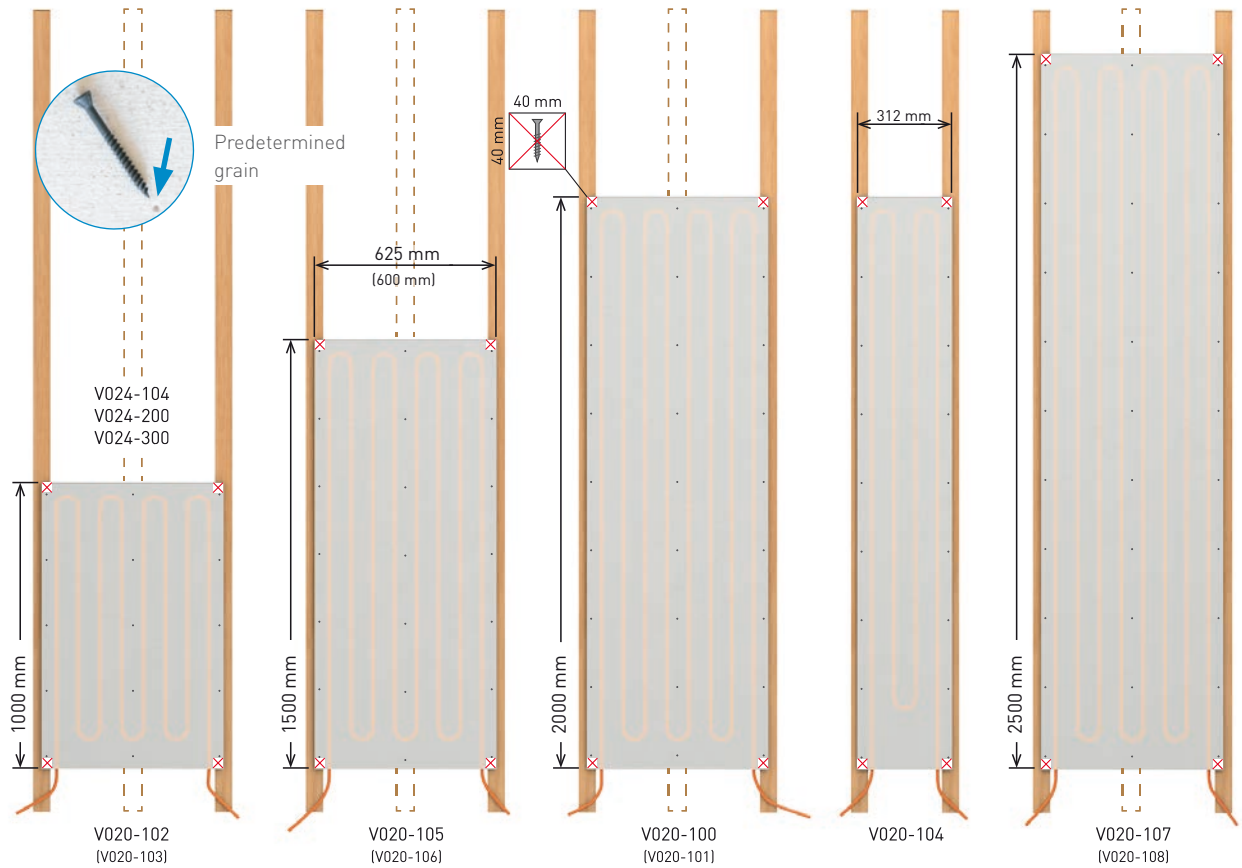

Fastening area of the ModularPanels - (pipe spacing 75 mm) batten crosswise

Spacing of the battens depends on the panel height (see Chapter 3).
Predetermined grain CANNOT be used.

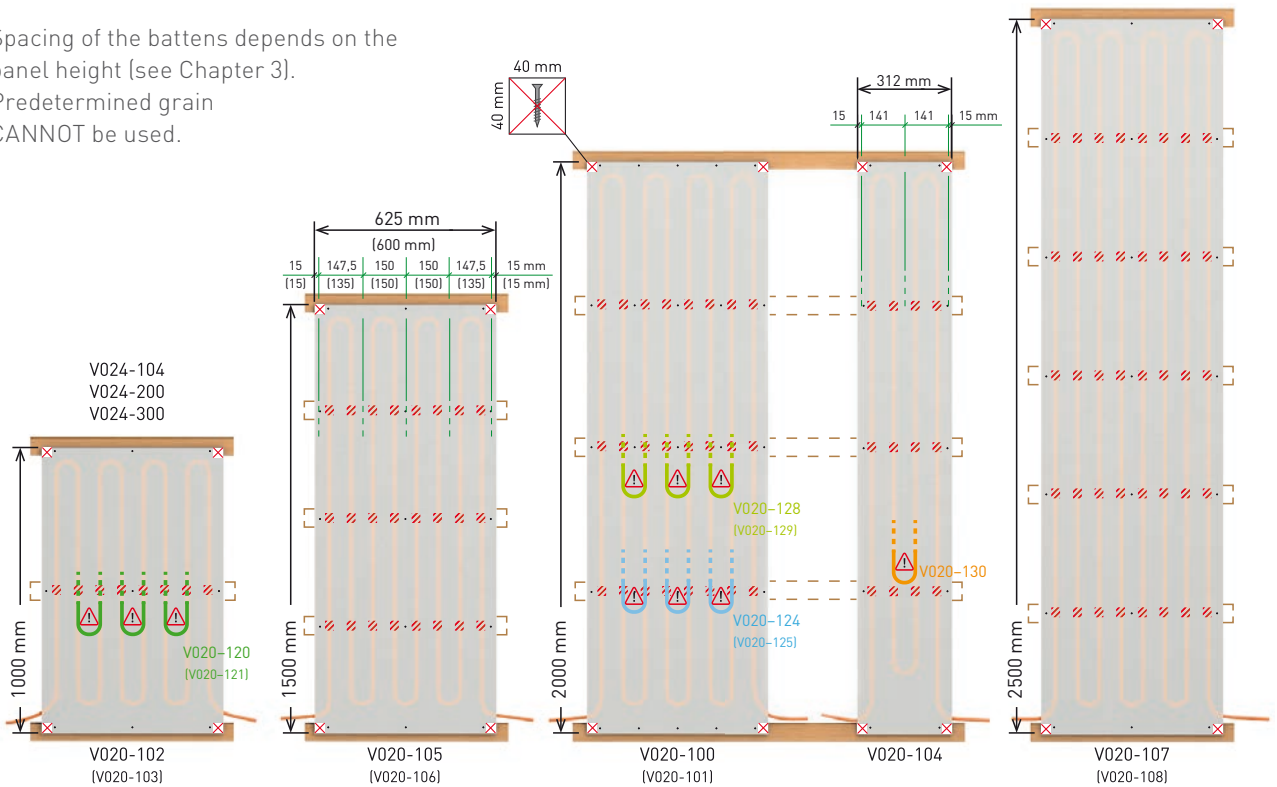

Fastening area of the ModularPanels - (pipe spacing 105 mm) batten lengthwise

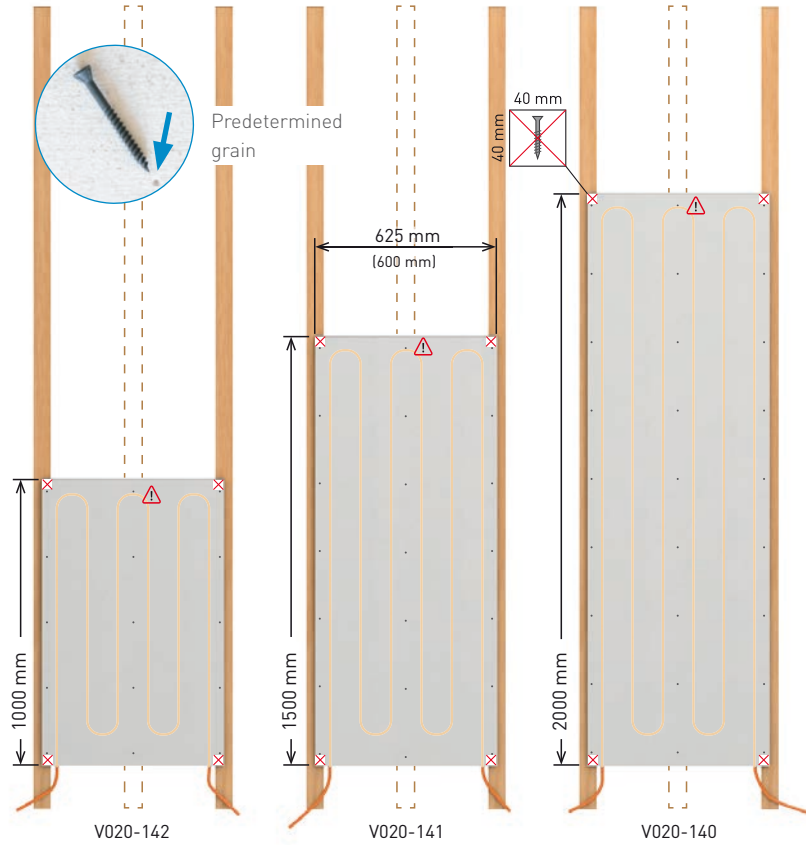

Fastening area of the ModularPanels - (pipe spacing 105 mm) batten crosswise

Spacing of the battens depends on the panel height (see Chapter 3).
Predetermined grain CANNOT be used.

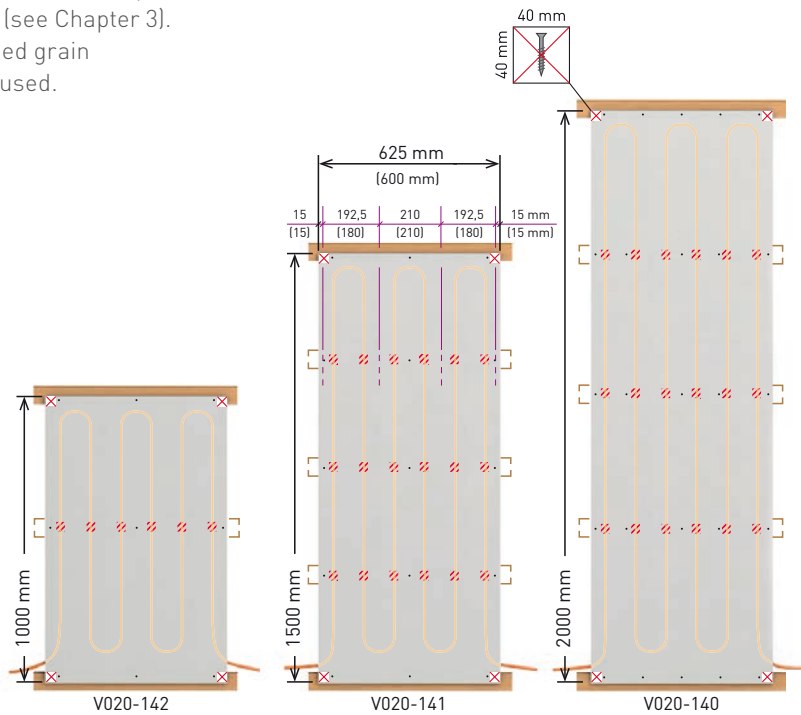

Panel connections

Connections to walls or pitched roofs are to be constructed as grouted joints (approx. 7 mm) with a separating layer (adhesive tape) or using termination angles (decoupled connections) **Caution:** Pay attention to the VarioModular pipes when fastening the ModularPanels in the connection areas (deviation from fastening area)! For further information on filling, see also Chapter 6.1!

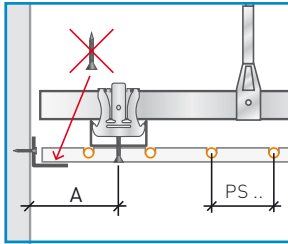

▲ Connection with termination angle

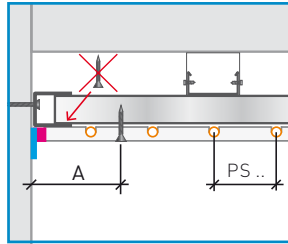

▲ Connection with UD profile – battens transverse to the panel

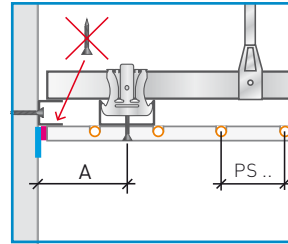

▲ Connection with UD profile – battens longitudinal to the panel

A = 85 mm at PS 75 mm, resp.
A = 105 mm at PS 105 mm.
PS ... Pipe Spacing
Separating layer (tape) ■
Grouted joint (approx. 7 mm) ■

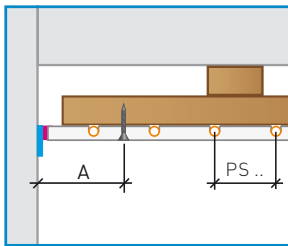

▲ Connection with separating strip

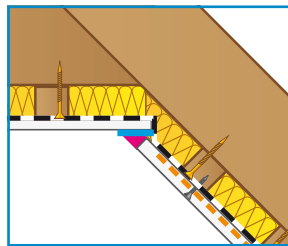

▲ ModularCeiling to roof pitch

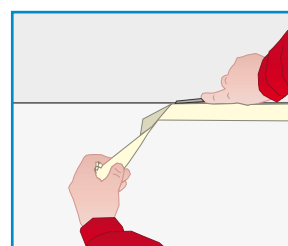

▲ The protruding separating layers (adhesive tape ■) are only removed after filling!

Movement joints

Movement joints are to be provided every 8 m in ceiling constructions.

Caution: Pay attention to the VarioModular pipes when fastening the ModularPanels in the area of the movement joints!

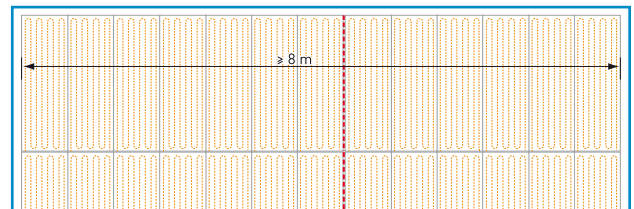

▲ Movement joint at e.g. 13xV020-100 (13x0.625 m = 8.13 m)

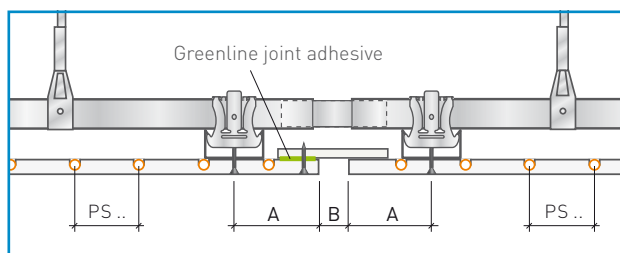

▲ Movement joint with panel strips,
B = 10–20 mm (movement dimension)

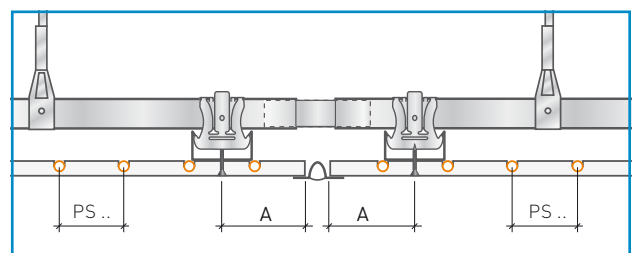

▲ Movement joint with additional profile

A = 85 mm at PS 75 mm, resp. A = 105 mm at PS 105 mm; PS ... Pipe Spacing

Panel installation between already installed ModularPanels

If "step-by-step" installation of the ModularPanels is not possible, proceed as follows:

- 1 Glue one side of the ModularBlankPanel using greenline joint adhesive.
- 2 Leave a 3 to 8 mm gap on the other side.
- 3 Completely fill the gap with **Variotherm Duo adhesive** (special **W048 manual applicator** required!).

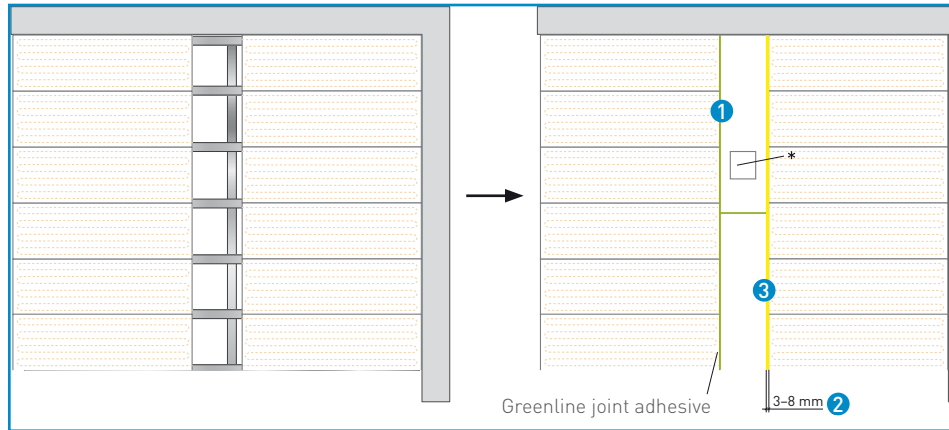

*e. g. inspection opening, from RUG Semin or UPMANN with 18 mm plasterboard insert. Please observe the installation instructions of the manufacturer!

Processing the Duo Adhesive:

- > The surfaces of the ModularPanels must be clean, dry, dust-free and grease-free.
- > Open the cartridge – screw on the static mixing tube.
- > Insert the cartridge into the Duo manual applicator.
- > For safety reasons, do not use the first amount of mixed adhesive for gluing (20 g, approx. walnut-sized).
- > Completely fill the joint from the top to the bottom using the static mixing tube.
- > For a better filling result, use a pointing trowel (or similar) to slightly hollow out the fresh joint.
- > Remove excess adhesive when still fresh. Hardened adhesive can only be removed with great effort.
- > The static mixing tube remains on the cartridge unit at the end of work/during breaks – the static mixing tube is then replaced the next time work begins again.
- > The joint can be covered with filler 4 hours after gluing the panels (working temperature > +15 °C).

Safety information:

Keep out of the reach of children! For further information see the product label or the safety data sheets according to Regulation 1907/2006/EC, Annex II, available at www.variotherm.com/en/service/info-centre/safety-data-sheets.html.

Wear suitable protective gloves. Protect your skin, eyes, clothing and tools from coming into contact with unhardened Duo adhesive. In the case of skin contact clean immediately with soap and water. Clean contaminated tools immediately with universal thinner. Hardened adhesive can only be removed mechanically.

Technical data:

Basis: 2-component PUR reaction adhesive

Colour when hard: beige

Viscosity at +20 °C: low-viscosity paste

Working time (at +10/+20/+30 °C): approx. 60/30/15 minutes

Hardening time (+20 °C, 50 % relative humidity): approx. 24 hours, final hardness after approx. 7 days

Working temperature: minimum of +7 °C to a maximum of +30 °C

Net weight: 900 g (2 x 310 ml tandem cartridge)

Consumption: 1 cartridge is sufficient for an approx. 7 m joint (4 mm width and 18 mm depth)

Storage: unopened, in a dry place at +15 °C to +25 °C approx. 15 months

- > Duo Adhesive
- > Part No.: F115
- > PKU: 1 Cartridge
Carton with 10 cartridges
- > Weight/PKU: 1 kg
- > Consumption: ~7 m joint
(4 mm width, 18 mm depth)
- > Special manual applicator W048 required!

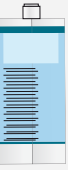

- > Static mixing tube
- > Part No.: F116
- > PKU: 1 pce.
Carton with 75 pcs.
- > Weight/PKU: 15 g
- > Consumption: ~3 pcs./cartridge



- > Duo manual applicator
- > Part No.: W048
- > PKU: 1 pce.
Weight/PKU: 1.4 kg
- > The matching manual applicator for applying the Duo adhesive.

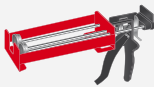



5.3 VarioModular pipes

- 1 Temperature-resistance polyethylene (PE)
- 2 Adhesive layer
- 3 Homogeneous and solid aluminium pipe
- 4 Adhesive layer
- 5 Raised-temperature-resistance polyethylene (PE-RT)

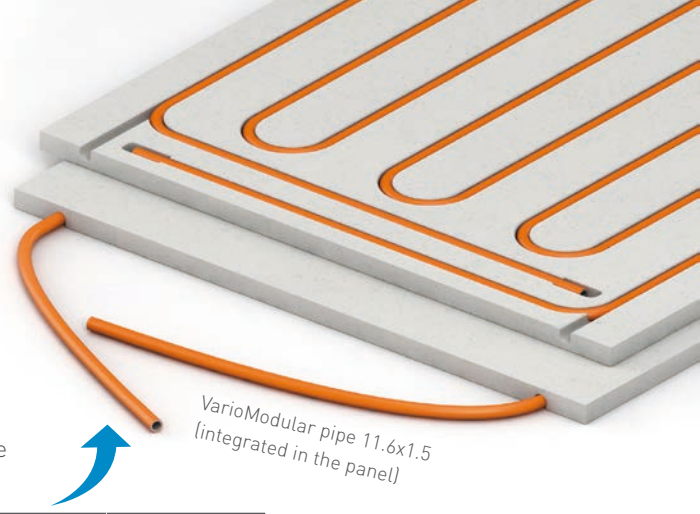

VarioModular pipe 11.6x1.5 (integrated in the panel)

Technical data	11.6x1.5	(pre-insulated) 16x2
Pipe diameter	11.6 mm	16.0 mm
Pipe wall thickness	1.5 mm	2.0 mm
Aluminium pipe thickness	0.15 mm	0.18 mm
Water content	0.058 l/m	0.113 l/m
Special narrow bending radius (use a suitable bending device)	30 mm	40 mm
Max. operating temperature [t _{max}]	70 °C	70 °C
Short-term resistant [t _{ma}]	95 °C	95 °C
Max. operating pressure [p _{max}]	6 bar	6 bar
Linear expansion coefficient	2.3 × 10 ⁻⁵ [K ⁻¹]	2.3 × 10 ⁻⁵ [K ⁻¹]
Mean heat conduction coefficient [λ]	0.44 W/mK	0.45* W/mK
Heat transmission resistance	0.0034 m ² K/W	0.0045* m ² K/W



Pre-insulated VarioModular pipe 16x2 (supply pipe), Insulation thickness 6 or 9 mm

<< * Values without insulation

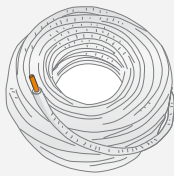

- > Pre-insulated 16x2 VarioModular pipe
- > Part No.: V1226 (6 mm Insulation)
- > V1227 (9 mm Insulation)
- > PKU: Roll with 100 m
- > Weight/PKU: 14.0 kg (6 mm Insulation) 14.9 kg (9 mm Insulation)
- > Insulation: Polyethylene soft foam
- > Fire resistance as per EN 13501-1: CL-s1,d0

- > Retaining clamp ø35
- > Part No.: V2802
- > PKU: 50 pcs.
- > Weight/PKU: 1 kg
- > for affixing the pre-insulated VarioModular pipes 16x2



- > Retaining clamp ø35
- > Part No.: V2803
- > PKU: 25 pcs.
- > Weight/PKU: 1 kg
- > for affixing the pre-insulated VarioModular pipes 16x2



Advantages

- > Fully corrosion-free
- > Optimum creep behaviour
- > Just as light as a plastic pipe
- > 10-year guarantee with certificate
- > Flexible, easy to bend, extremely stable form
- > Resistant to hot water additives (inhibitors, antifreeze)
- > Mirror-smooth inner surface – less pressure loss – no encrustation
- > High pressure and temperature resistance
- > 100 % oxygen diffusion-tight
- > Low linear coefficient of expansion, low heat expansion forces
- > Tested as per EN 21003

Creep behaviour

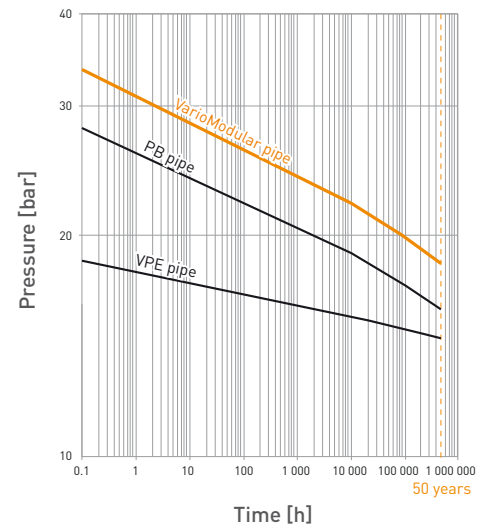

Elongation

with 10 m and temperature difference Δt 25 °C (e. g. 20 °C to 45 °C)

Pipe material	Elongation
Plastics	PEX (VPE) 50.00 mm
	PP 42.50 mm
	PB 32.50 mm
	PVC 20.00 mm
VarioModular pipe	5.75 mm
Metal	Cu 4.20 mm
	Stainless steel 3.50 mm
	Steel 2.88 mm

Homogeneous plastic pipes produce high stress levels in the device because of their expansion coefficient.

The VarioModular pipe combines the minor elongation and thermal expansion. So it is perfect for surface cooling/heating pipes.

5.4 Press-fit couplings / press tools

Connection options

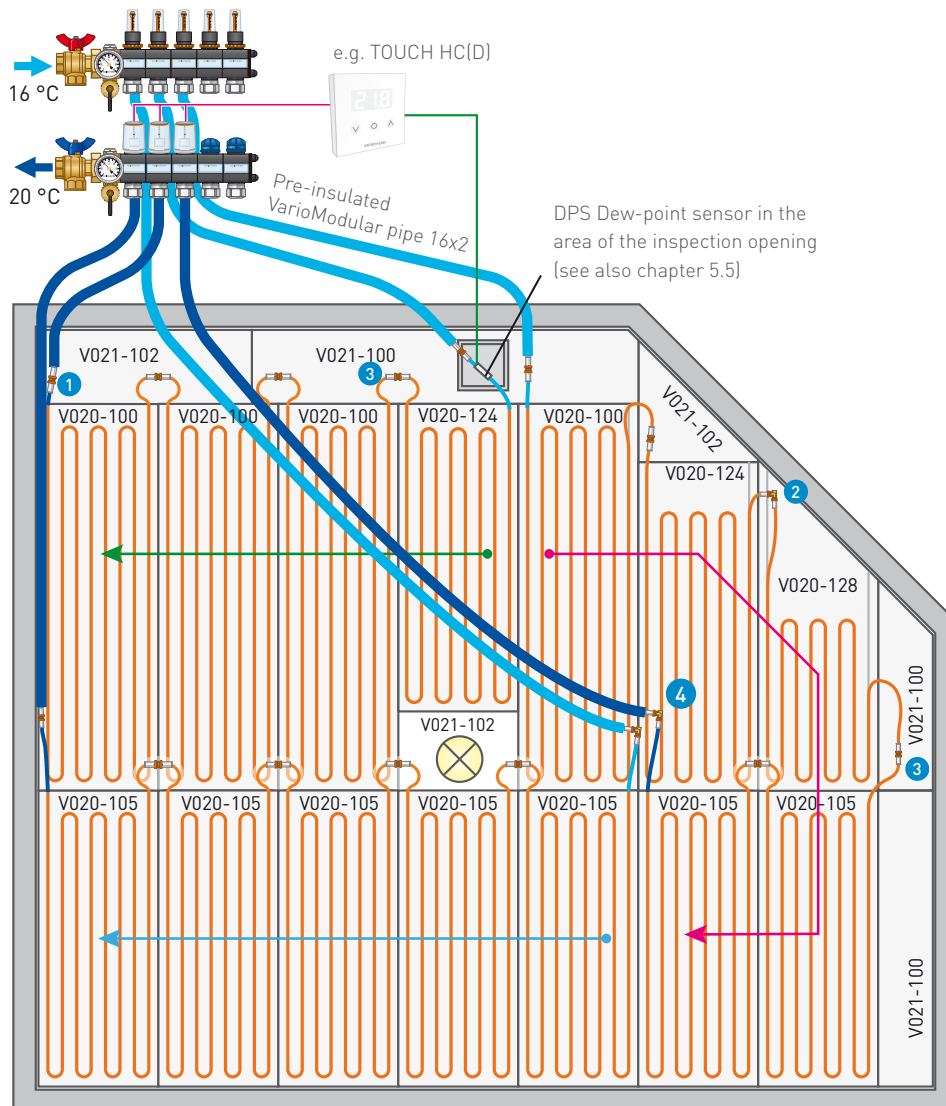

- › Press-fit coupling 16x11.6 **1**
- › Part No.: Z1610
- › PKU: 1 pce.
- › Weight/PKU: 45 g
- › Press contour: TH11.6 & TH16



- › Press-fit elbow 90° 11.6x11.6
- › Part No.: Z1630
- › PKU: 1 pce.
- › Weight/PKU: 45 g
- › Press contour: TH11.6

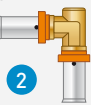

- › Press-fit coupling 11.6x11.6 **3**
- › Part No.: Z1600
- › PKU: 1 pce.
- › Weight/PKU: 30 g
- › Press contour: TH11.6



- › Press-fit elbow 90° 16x11.6
- › Part No.: Z1620
- › PKU: 1 pce.
- › Weight/PKU: 45 g
- › Press contour: TH11.6 / TH16

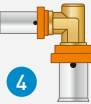

Maximum cooling/heating surface
per cooling/heating circuit

6.25 m²

[e.g. 5 x V020-100]

Observe pump dimensioning!

Pressure loss examples (t_i = 20 °C)

Flow/Return	6.25 m ² / circuit	5.0 m ² / circuit
🔥 35/28 °C	1.3 mWC	0.8 mWC
🔥 35/30 °C	2.7 mWC	1.6 mWC

Pressure loss examples (t_i = 26 °C)

* 16/20 °C	3.2 mWC	1.7 mWC
------------	---------	---------

- > Calibration and chamfering tool
- > Part No.: W042
- > PKU: 1 pce.
- > Weight/PKU: 140 g
- > For calibrating and chamfering the Variotherm pipes



- > Pipe cutting pliers
- > Part No.: W037
- > PKU: 1 pce.
- > Weight/PKU: 230 g
- > For trimming the Variotherm pipes
- > Replacement blade: W0371



- > AkkuPress Mini
- > Part No.: W019
- > PKU: 1 pce.
- > Weight/PKU: 9.9 kg
- > Incl. sheet steel box, press-fitting jaws TH16 Mini & TH11.6 Mini, battery charger, 2 batteries

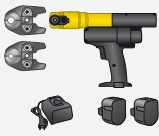

- > Mini press-fitting jaw TH11.6
- > Part No.: W031
- > PKU: 1 pce.
- > Weight/PKU: 1,5 kg



- > Mini press-fitting jaw TH16
- > Part No.: W032
- > PKU: 1 pce.
- > Weight/PKU: 1.6 kg



- > EcoPress
- > Part No.: W015
- > PKU: 1 pce.
- > Weight/PKU: 9.7 kg
- > Incl. sheet steel box, press-fitting jaws TH16 & TH11.6

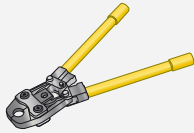

- > Press-fitting jaw TH11.6
- > Part No.: W025
- > PKU: 1 pce.
- > Weight/PKU: 2.0 kg



- > Press-fitting jaw TH16
- > Part No.: W024
- > PKU: 1 pce.
- > Weight/PKU: 2.1 kg



- > Cold shrinking tape
- > Part No.: Z1699
- > PKU: 1 pce. | Carton with 20 pcs.
- > Weight/PKU: 990 g
- > Roll: 50 mm x 15 m
- > 1 roll is sufficient for approx. 35 press-fit coupling connections (with a 50 % overlap)



Pipe connection / pressing

Once the panels and the heating/cooling manifolds are installed, the panels are connected to the desired circuits. The pre-insulated VarioModular pipe16x2 is used as the supply pipe. A lasting, secure connection is only guaranteed if original Variotherm system components are used:

- > VarioModular pipes
- > Variotherm calibration and chamfering tools
- > Variotherm press-fit couplings and Variotherm pressing tools

The relevant operating instructions for the pressing tools are included with the appliances.

The press-fitting pliers and drive unit must be checked at least once a year for correct operation by REMS or an authorised REMS customer service workshop.

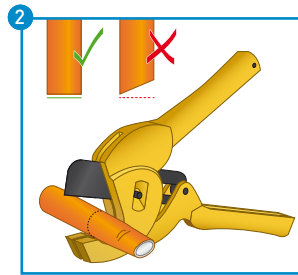
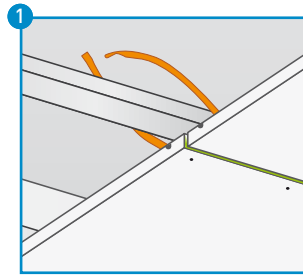

▲ Cut the pressed pipe ends at a right angle

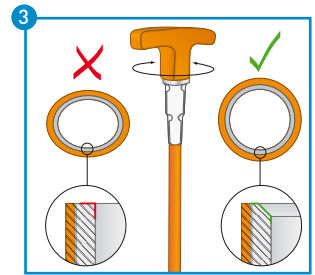

▲ Calibration and chamfering the pipe ends

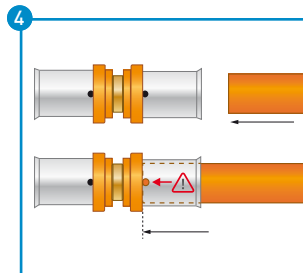

▲ Slide the press-fit coupling on as far as it goes

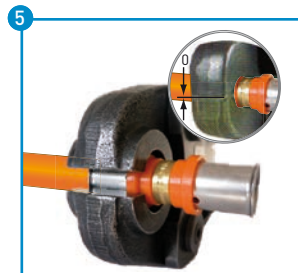

▲ Pressing. Press-fitting pliers must close completely.

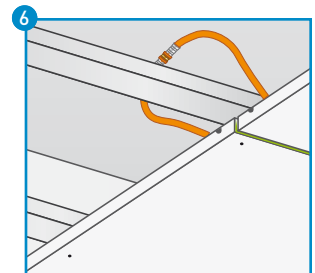

▲ Connected Modular Panels

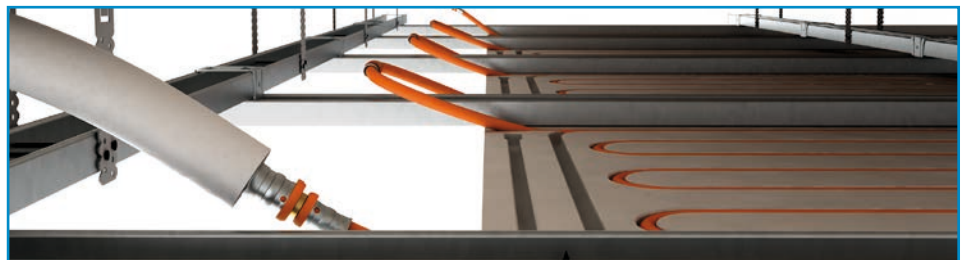

Corrosion prevention measures/ dew-point monitoring

The connecting elements are to be protected (after the pressure test) in accordance with EN 1264 and compliance with ÖN H 5155 (e.g. with Z1699 cold shrink tape). This measure is also a prerequisite for effective dew-point monitoring in the case of cooling (see also Chapter 5.5)

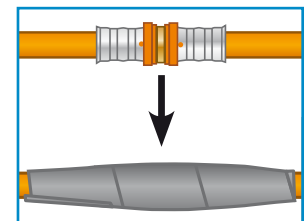

5.5 Dew-point monitoring/sensor DPS

The dew-point sensor is mounted e. g. with cable ties to the part of the pipe where condensation is expected to form first. This is normally the case on the supply inlet. Care must be taken that there is a good thermal transfer between the pipe and the sensor (use thermal paste!) and that there is a stream of ambient around area of the dew point sensor. For this reason an ambient air connection must be created in the area of the dew-point sensor in the case of closed ceilings. The supply must be fixed adequately.

Dew point monitoring is possible with optional DPS dew point sensor (RT495) in combination with the TOUCH HC(D) (RT49) room thermostat!

For further information on the dew point, see also Chapter 8.3.

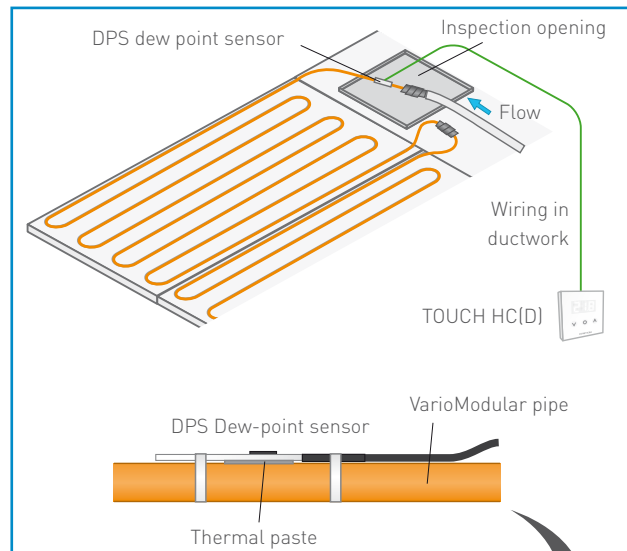

▲ Example Dew-point monitoring (cooling)

5.6 VarioManifold

Advantages

- › Plastic manifold with internal air chambers for thermal insulation
- › Flexible conversion to thermostat operation
- › Pre-settable flow indicator in the flow (10-160 l/h) according to EN 1264-4, viewing glass can be cleaned
- › Optimised for **low-temperature** surface heating/cooling
- › Detachable 3-way ball valves on the flow and return
- › Venting option, flushing option via rotatable fill and drain cocks
- › Modular construction
- › Absolutely oxygen-tight
- › Designation labels
- › All parts self-sealing, manifold pressure-tested
- › Variable distance between flow and return bars

Pressure test

Once all circuits have been connected to the heating/cooling manifold, the system can be filled downstream of the manifold and pressurised. The pipes must be kept under water pressure prior to completion work (screeding, filling, painting, wallpapering, tiling), so that any damage becomes immediately visible. (Please see Chapter 9.1 for the protocol Leak-tightness test).

For details regarding the system and cooling/heating circuit pipes and the room temperature control please refer to the "DISTRIBUTION and CONTROL" planning and installation instructions



PDF

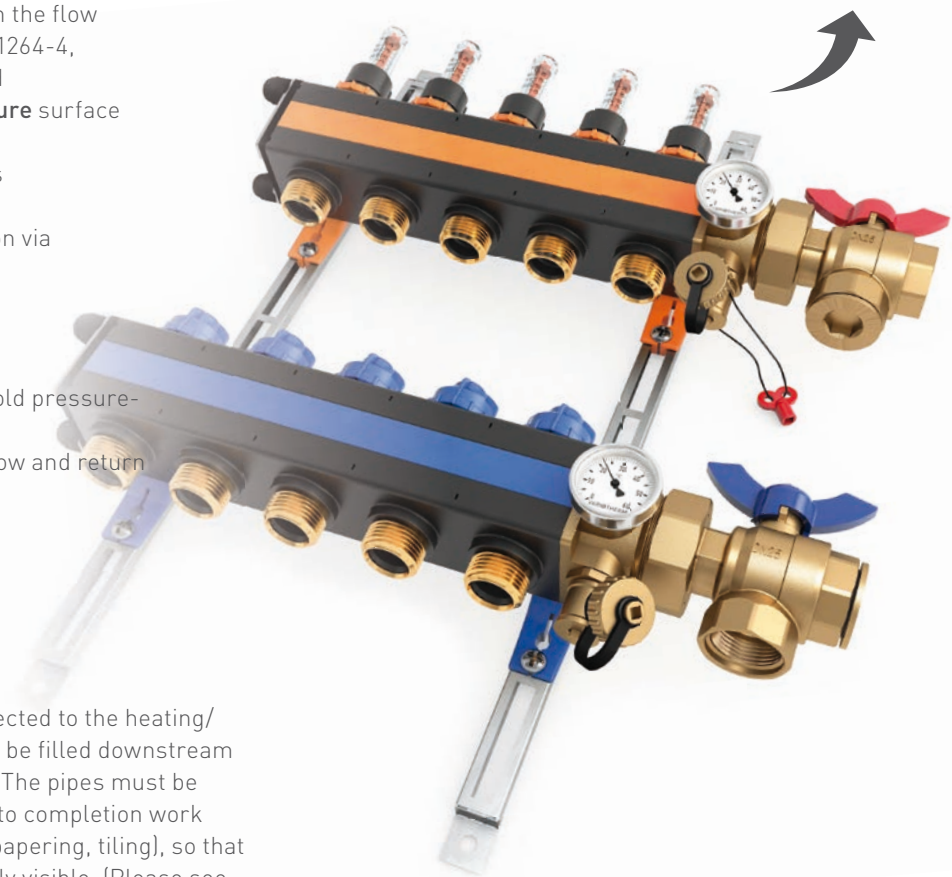

6 FINISHED SURFACE

6.1 Filling

After installation, the ModularPanels and ModularBlankPanels are filled with FERMACELL Joint Filler or Fine Surface Filler (or equivalent products). However, before this the joint adhesive that has already hardened must be completely scraped off (depending on the room temperature, the joint adhesive has hardened after approx. 18 to 36 hours). Joint adhesive that is still soft smears when you try to remove it.

Caution: Filling may only be carried out after all wet work (wet screed, plastering, etc.) has dried!

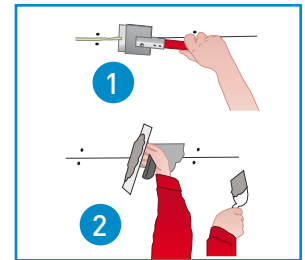

Depending on the required surface quality, the following work must be carried out:

Q1 – Minimum requirement	Q2 – Standard requirement	Q3 – High requirement	Q4 – Highest requirement
<u>Necessary for:</u> - Sealing layers and tiling	<u>Necessary for:</u> - Wallpaper and woodchip (medium or coarse grain) - Matt fillers (dispersion coating, thin plaster)	<u>Necessary for:</u> - Fine-textured wall coverings - Matt, non-textured wall coverings	<u>Necessary for:</u> - Smooth or fine-textured wall coatings - Metal or thin vinyl wallpapers - High-quality finishing technologies
<u>Required work:</u> - Scrapping off excess joint adhesive after hardening ① - Filling of visible fixings and adhesive joints with Fermacell Joint Filler or Fine Surface Treatment ②	<u>Required work:</u> - Q1 - Smooth and continuous filling of joints and fixings. No processing marks or filler burrs must remain visible. If necessary, the smoothed surfaces should be sanded	<u>Required work:</u> - Q2 - If necessary broad filling of joints - Full-surface coating and sharp pulling-off of entire surface with Fermacell Fine Surface Treatment or other suitable filling materials. If necessary, the smoothed surfaces should be sanded	<u>Required work:</u> - Q2 - If necessary broad filling of joints - Full-surface coating and smoothing (e.g. with abrasive grid) of entire surface with Fermacell Fine Surface Treatment or other suitable filling materials.
	Settling of joints can't be ruled out, particularly under grazing light	Unevenness visible under grazing light, such as application marks on joints, cannot be excluded, but the unevenness is less than for Q2.	Unevenness at the joints must not be visible.

6.2 Painting

After filling, commercially available paints, such as latex, dispersion or gloss paints, can be applied to the ModularPanels. Mineral paints such as lime and silicate paints must be approved by the manufacturer for use on gypsum fibreboards. The paint is usually applied in two steps.

6.3 Load attachment of the ModularCeiling

Small "static" loads can be attached directly to the ModularCeiling according to the following table. **Caution:** Do not damage the VarioModular pipes!

Fixing material - observe the fitting instructions of the dowel manufacturer!	Permissible single loads for individual hanging on ModularPanel (dowel spacing \geq 300 mm)	Max. permissible area load per m ² ModularPanel (dowel spacing \geq 300 mm)
	2 kg	6 kg

Heavier suspended elements must only be attached to the substructure and not to the ModularPanel. When installing the substructure these loads must be taken into account (see maximum permissible support span, Chapter 3).

7 ACOUSTICS

Variotherm also offers ModularPanels with sound absorbent properties that significantly reduce the sound levels in living areas and offices. The holes in the gypsum fibre boards channel the impinging sound waves through the panel, where the sound energy is then "broken" and dispersed in the ceiling structure.

A special detail: With the Variotherm ceiling cooling/heating system, the holes of the acoustic panels are not covered by cooling/heating elements and thus remain 100 % active. This allows a tested and guaranteed sound reduction to be achieved.

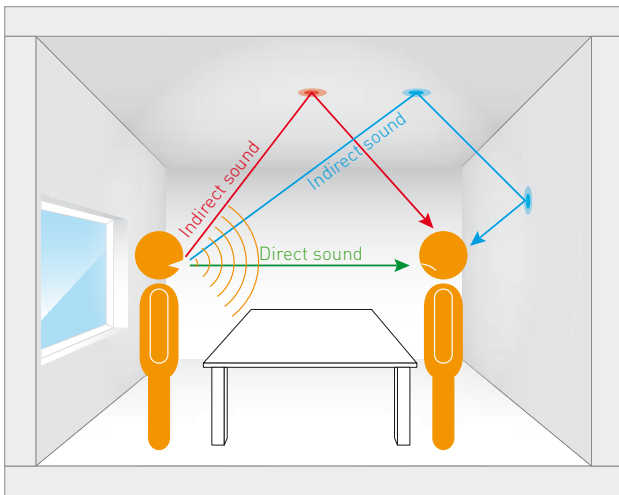

▲ Acoustic reflection

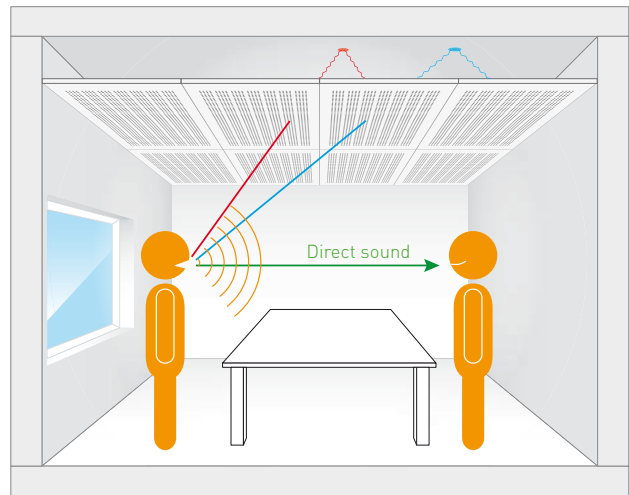

▲ Acoustic reflection with ModularPanel-Acoustic

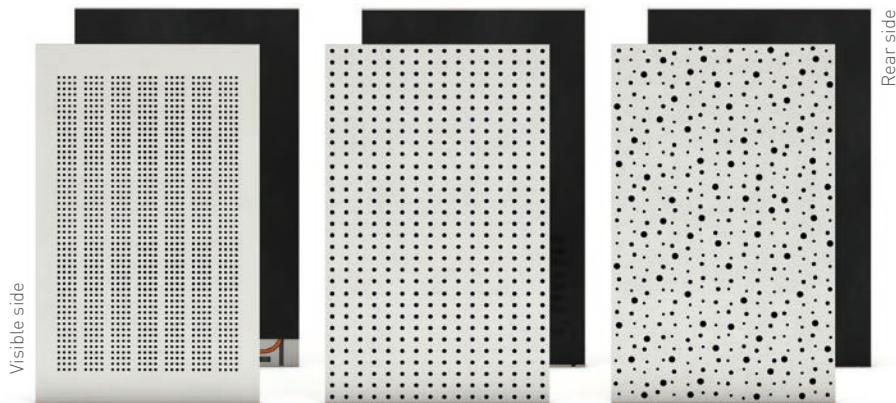
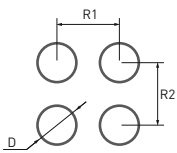

	B08	V1212	S081218
Part No.	V024-104	V024-200	V024-300
Hole diameter [D]:	8 mm	12 mm	8 12 18 mm
Hole spacing [R1]:	15.0 mm	39.0 mm	-
Hole spacing [R2]:	16.0 mm	32.0 mm	-
Hole percentage:	12.4 %	9.0 %	7.8 %
Hole pattern:	Block-Perforation	Full-Perforation	Random-Perforation
Tested by:	TÜV Rheinland according to DIN EN ISO 354 ¹	Testing follows ...	Testing follows ...
Panel material:	Gypsum fibreboard which has been tested for their healthy building properties, 18 mm		
Panel size:	1000 x 625 mm		
Pipe:	VarioModular pipe 11.6x1.5		
Acoustic fleece (Rear side):	Colour: Black Air permeability: ~750 L/m ² /s at 2 mbar pressure difference (EN ISO 9237) Air flow resistivity ~192 Ns/m ³ (DIN EN 29053)		



¹ Test values on request or as download:



8 HEATING/COOLING PRACTICE

8.1 Calculation of the heating and cooling load

Variotherm also conducts cooling load calculations (subject to a fee) according to the new VDI 2078 guideline. For calculation purposes, precise information must be provided on the building and the rooms to be cooled (U-values with layer composition, shading, internal loads). This is the precondition for useful, accurate results.

The EN 12831 standard with the respective national annex applies to the heating load calculations for the heated rooms.

Every room is considered individually. For the outside temperature, the locally acquired and standardised outdoor temperature T_{ne} is used.

8.2 Variotherm Dimensioning software

Key values for individual heating/cooling circuits (the amount of water, pressure loss, number of circuits, allocation of the manifolds etc.) can be quickly and easily calculated by inputting the cooling or heating load into the Variotherm dimensioning software. It can be found in our Professional Area at: www.variotherm.com/professional.

Bezeichnung	Fläche m ²	Kühllast W	Kühllast W/m ²	t _{Raum} °C	t _{op, Raum} °C
Schlafzimmer	21.70	-1601	-73.76	24.0	23.9
Wohnen, Kochen, Essen	84.50	-2906	-34.39	24.0	24.8
Wirtschaftsraum	13.00	-455	-35.01	24.0	24.6
WC	4.60	-73	-15.89	24.0	24.1
Corridor + Stiege	29.40	-1822	-61.96	24.0	25.4
Lounge + Stiege	22.00	-459	-20.85	24.0	24.3
Küche II (Pantry)	30.50	-956	-31.35	24.0	24.8
Vorraum	10.00	-239	-23.94	24.0	24.5
Küche II (Pantry)	14.00	-414	-29.55	24.0	24.6
Gästezimmer 1	23.50	-613	-26.08	24.0	24.6
Flur + Stiege	12.40	-342	-27.59	24.0	24.6
Gästezimmer 2	28.70	-746	-25.98	24.0	24.5
	294.30	-10625	-36.10		

▲ Excerpt of a cooling load calculation (German)

Übersicht der Bauteile

Code	Bezeichnung	U-Wert W/m ² K	Rges m ² K/W	Rsi m ² K/W	Rse m ² K/W	R-Baut m ² K/W
AF01	Außenfenster	1,100	0,909	0,130	0,040	0,739
AT01	Außentür	1,700	0,588	0,130	0,040	0,418
AW01	Außenwand	0,220	4,545	0,130	0,040	4,375

Raum	Nr.	Bezeichnung	Φ _{ext}	A _{ext}	Φ _{ext}	Φ _{int}	Φ _{ext}	Φ _{int}	Φ _{ext}	Φ _{int}	Φ _{ext}	Φ _{int}
			°C	m ²	W	W	W	W	W	W	W	W
Haus, EG			180.88	5427		3396				9160		0 9160
00.001.001	Eltern		20.0	29.10	833	833	501	46	15	1335	0	1335
00.001.002	Kinder		20.0	20.49	762	762	343	54	19	1106	0	1106
00.001.003	Vorraum		20.0	24.40	571	571	409	40	14	980	0	980

▲ Excerpt of a cooling load calculation (German)

Dimensioning of Variotherm Cooling Systems																				
Building project: _____ ZIP: _____ City: _____ Date: _____ Processed by: as																				
No. Room name	Floor space A [m ²]	Cooling load Q [W]	Supplement cooling load Suppl. [%]	Cooling load incl. Supplement Q+Suppl. [W]	Room temp. t _R [°C]	Cooling system	Floor covering [m ²] or pipe covering [mm]	Dimensioning temperature t _R [°C]	Mathematical			Practical			Supply pipe per circuit [m]	Supply line length per circuit [m]	Pressure loss per circuit [mWC]	Flow quantity per circuit [l/h]	Distribution manifold number	Calculation of pressure loss and flow rate 2 systems at 4 cooling circuit (see manual)
									Dim.	Unit	Type	No. of circuits	Dim.	Unit						
Room 1	21,16	1021		1021	26	ModuleWall MWHK	16/20	16/20	19,26 m ²	MWHK	3	5,80 m ²	MWHK	-99	-		2,30	67	•1	
Cloakroom	10,15	564		564	26	ModuleCeiling MDKH	16/20	16/20	9,40 m ²	MDKH	2	4,50 m ²	MDKH	-24	-		1,47	59	•1	
Room 2	23,04	1032		1032	26	ModuleWall MWHK	16/20	16/20	19,47 m ²	MWHK	3	5,80 m ²	MWHK	-110	-		2,30	67	•1	
Kitchen-living room	33,14	1543		1543	26	ModuleWall MWHK	16/20	16/20	29,11 m ²	MWHK	5	5,00 m ²	MWHK	-218	-		1,59	58	•1	
Auntenroom	6,00	335		335	26	ModuleWall MWHK	16/20	16/20	6,32 m ²	MWHK	1	4,50 m ²	MWHK	-97	-		1,25	52	•2	
Room 3	26,04	1245		1245	26	ModuleCeiling MDKH	16/20	16/20	20,75 m ²	MDKH	4	5,00 m ²	MDKH	-45	-		1,93	65	•2	
Room 4	17,08	654		654	26	ModuleCeiling MDKH	16/20	16/20	10,90 m ²	MDKH	3	5,00 m ²	MDKH	246	-		1,93	65	•2	

▲ Variotherm dimensioning software example for cooling

Dimensioning of Variotherm Heating Systems																					
Building project: _____ ZIP: _____ City: _____ Date: _____ Processed by: as																					
No. Room name	Floor space A [m ²]	Maximum length L [m]	Heating load Q [W]	Supplement heating load Suppl. [%]	Heating load incl. Supplement Q+Suppl. [W]	Room temp. t _R [°C]	Heating system	Floor covering [m ²] or pipe covering [mm]	Dimensioning temperature t _R [°C]	Mathematical			Practical			Supply pipe per circuit [m]	Supply line length per circuit [m]	Pressure loss per circuit [mWC]	Flow quantity per circuit [l/h]	Distribution manifold number	Calculation of pressure loss and flow rate 2 systems at 4 heating circuit (see manual)
										Dim.	Unit	Type	No. of circuits	Dim.	Unit						
Room 1	21,16		846		846	20	ModuleWall MWHK	35/28	35/28	10,08 m ²	MWHK	3	5,80 m ²	MWHK	615	-		1,95	60	•1	
Cloakroom	10,15		406		406	20	ModuleCeiling MDKH	35/28	35/28	6,95 m ²	MDKH	2	4,50 m ²	MDKH	152	-		0,77	35	•1	
Room 2	23,04		922		922	20	ModuleWall MWHK	35/28	35/28	10,97 m ²	MWHK	3	5,80 m ²	MWHK	540	-		1,95	60	•1	
Kitchen-living room	33,14		994		994	22	ModuleWall MWHK	35/28	35/28	15,30 m ²	MWHK	5	5,00 m ²	MWHK	631	-		1,02	41	•1	
Auntenroom	6,00		240		240	20	ModuleWall MWHK	35/28	35/28	2,86 m ²	MWHK	1	4,50 m ²	MWHK	138	-		1,06	47	•2	
Room 3	26,04		1042		1042	20	ModuleCeiling MDKH	35/28	35/28	16,80 m ²	MDKH	4	5,00 m ²	MDKH	198	-		0,95	39	•2	
Room 4	17,08		683		683	20	ModuleCeiling MDKH	35/28	35/28	11,02 m ²	MDKH	3	5,00 m ²	MDKH	247	-		0,95	39	•2	

▲ Variotherm dimensioning software example for heating

8.3 Cooling capacity and dew point

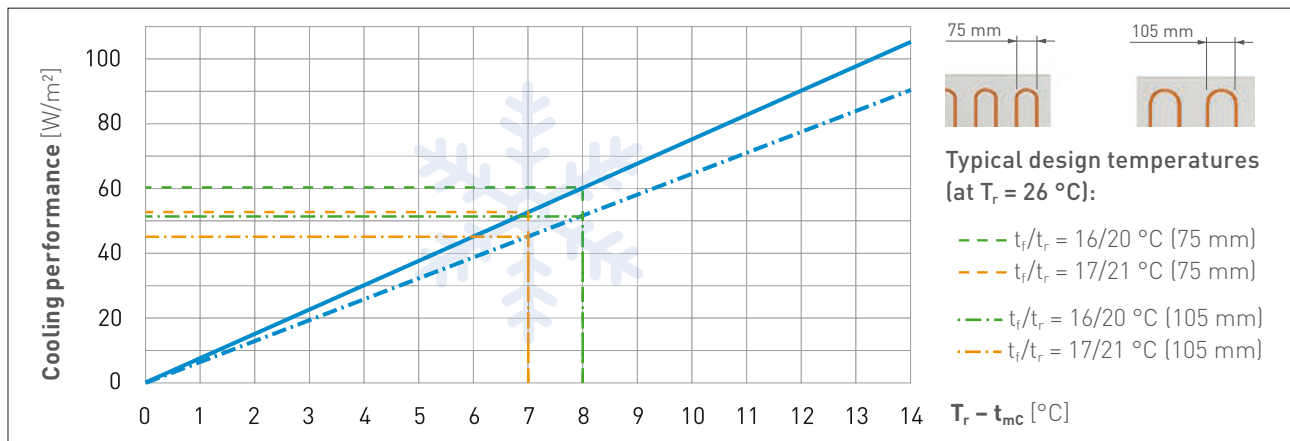

$$t_{mc} = \text{Mean cooling water temperature} = \frac{t_i + t_r}{2} \text{ [°C]}$$

$T_r = \text{Room temperature [°C]}$

$t_i/t_r = \text{Flow temperature / Return temperature [°C]}$

The flow temperature must be selected in such a way or it must be ensured that the surface temperature of the surface cooling (room-side and cavity) and the pipe never reaches or falls below the dew-point temperature at any point. Whereby the mean surface temperature T_0 corresponds approximately to the return flow temperature t_r .

Relative humidity [%rF]	Room temperature T_r [°C]				
	24	25	26	27	28
80 %	20.3	21.3	22.3	23.3	24.2
70 %	18.2	19.1	20.1	21.1	22.0
60 %	15.8	16.7	17.6	18.6	19.5
50 %	12.9	13.9	14.8	15.7	16.6
40 %	9.6	10.5	11.4	12.2	13.1

Dew-point temperature [°C]

Condensation can form on the pipes and surfaces if the flow temperature selected is too low. Control measures must be taken to prevent this (e.g. dew-point monitor, see also chapter 5.5).

8.4 Heat emission

Table valid for room heights of 2.5–3.5 m.

For reasons of comfort do not exceed $t_{mH} = 35\text{ °C}$!

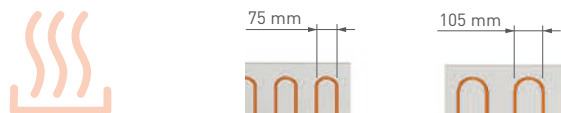

t_i/t_r [°C]	t_{mH} [°C]	Heat output [W/m²] at room temperature T_r ...										T_0 [°C]	
		... 15 °C		... 18 °C		... 20 °C		... 22 °C		... 24 °C		(at $T_r = 20\text{ °C}$)	
		75 mm	105 mm	75 mm	105 mm	75 mm	105 mm	75 mm	105 mm	75 mm	105 mm	75 mm	105 mm
30/20	25.0	55	46	39	33	27	22	15	12	-	-	27	27
30/25	27.5	68	57	54	45	41	34	28	23	15	12	28	28
35/25	30.0	82	69	67	56	55	46	42	35	28	23	29	28
35/28	31.5	90	76	75	63	62	52	49	41	36	30	30	29
35/30	32.5	96	81	81	68	68	57	55	46	42	35	31	30
37.5/32.5	35.0	110	93	95	80	82	69	69	58	55	46	32	31
40/30	35.0	110	93	95	80	82	69	69	58	55	46	32	31

$$t_{mH} = \text{mean hot water temperature} = \frac{t_i + t_r}{2} \text{ [°C]}$$

$T_r = \text{room temperature [°C]}$

$T_0 = \text{mean surface temperature [°C]}$

$t_i/t_r = \text{flow temperature / return temperature [°C]}$

8.5 Pressure loss

Example: The pressure loss of a 6.25 m² Modular ceiling cooling (5 pcs. V020-100 at 1 cooling circuit) is to be calculated. The desired flow/return temperature is 16/20 °C resulting in a cooling output of 60 W/m² at a room temperature of 26 °C.

Supply: pre-insulated VarioModular pipe 16x2.

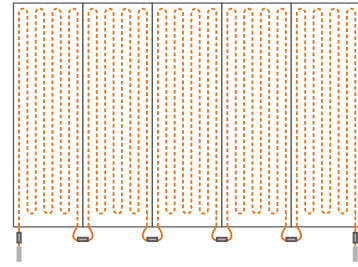

Calculation of the flow rate ω from the pressure loss diagram:

$$Q = 375 \text{ W (60 W/m}^2 \times 6.25 \text{ m}^2)$$

$$\Delta T = 4 \text{ K (20 K - 16 K)}$$

$$c = 1.163 \text{ Wh/kgK (Specific heat capacity of water)}$$

$$m = Q \div c \div \Delta T$$

$$= 375 \text{ W} \div 1.163 \text{ Wh/kgK} \div 4 \text{ K} = 80.6 \text{ kg/h (l/h)}$$

80.6 l/h results, according to the diagram, in:

Flow rate $\omega = 0.4 \text{ m/s}$

Pressure loss (Variotherm pipe 11.6x1,5) = 340 Pa/m

Pressure loss (Variotherm pipe 16x2) = 60 Pa/m

Pipe length for 6.25 m² cooling surface = 81 m

(1 pce. V020-100 = 16.2 m pipe, see table on page 16/17)

$$Q = m \times c \times \Delta T$$

Maximum flow rate per cooling/heating circuit of the VarioManifold:

160 l/h

Press-fit coupling	Coefficient of resistance ζ (Zeta)
11.6 x 11.6	7.2
16 x 11.6	6.9

- Δp for 6,25 m² ModularWall: 340 Pa/m \times 81 m = **27540 Pa**
- Δp for 15 m pre-insulated VarioModular pipe 16x2: 60 Pa/m \times 15 m = **900 Pa**
- Δp for 4 pcs. press-fit couplings 11.6x11.6: $\zeta \times \rho/2 \times \omega^2 = 7.2 \times 500 \text{ kg/m}^3 \times (0.4 \text{ m/s})^2 = 576 \text{ Pa} \times 4 \text{ pcs.} =$ **2304 Pa**
- Δp for 2 pcs. press-fit couplings 16x11.6: $\zeta \times \rho/2 \times \omega^2 = 6.9 \times 500 \text{ kg/m}^3 \times (0.4 \text{ m/s})^2 = 552 \text{ Pa} \times 2 \text{ pcs.} =$ **1104 Pa**

$$\Delta p_{\text{Total}} = 27540 \text{ Pa} + 900 \text{ Pa} + 2304 \text{ Pa} + 1104 \text{ Pa} = \mathbf{31848 \text{ Pa} = 3.18 \text{ mWC}}$$

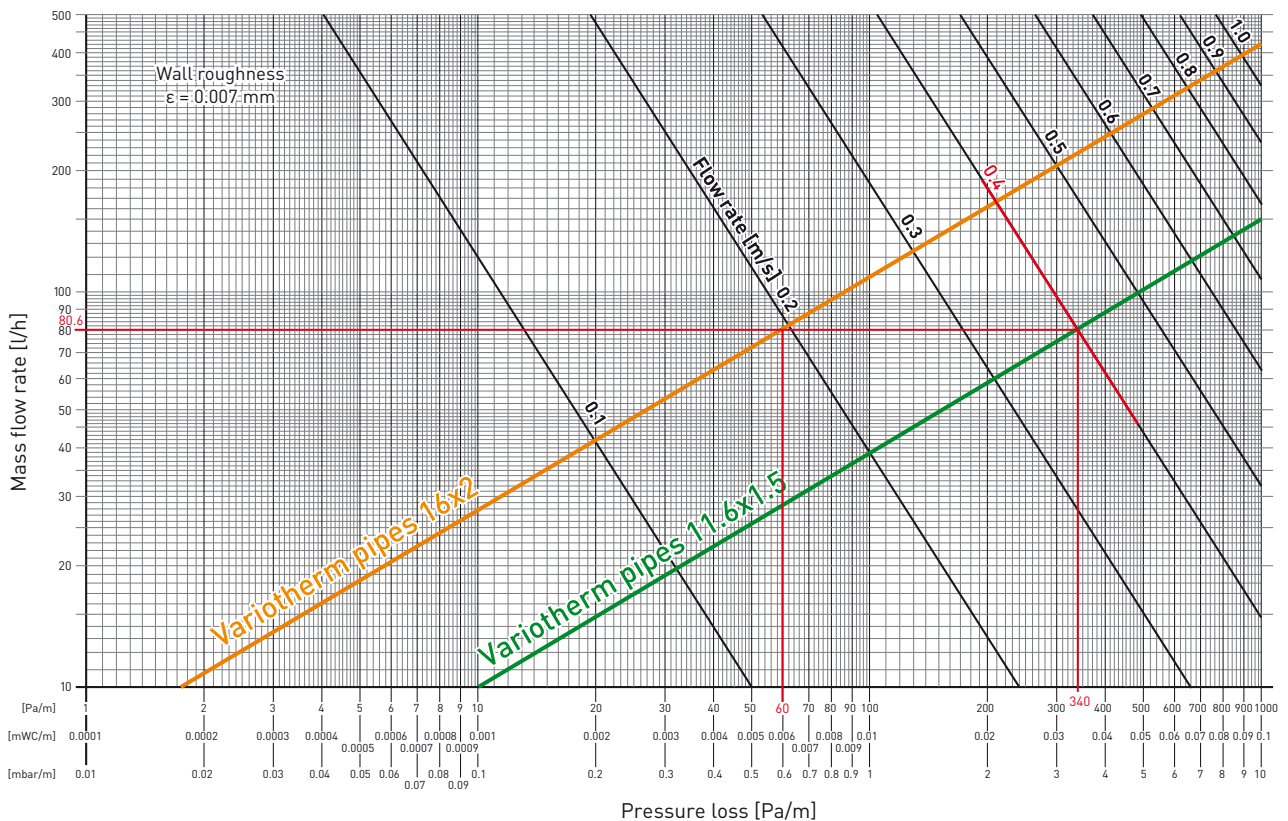

8.6 Arrangement of the cooling/heating surfaces

Ceilings and roof slopes are ideally suited as cooling and heating surfaces, as the radiation surfaces are not obstructed by furnishings.

Experience shows that the comfort effect is perceived up to 3.5 m away from the thermally active ceiling. As the radiation effect on the body declines in proportion to the square of the distance, it is advantageous to suspend the ceiling in higher rooms, or alternatively to combine it with wall heating/wall cooling or floor heating.

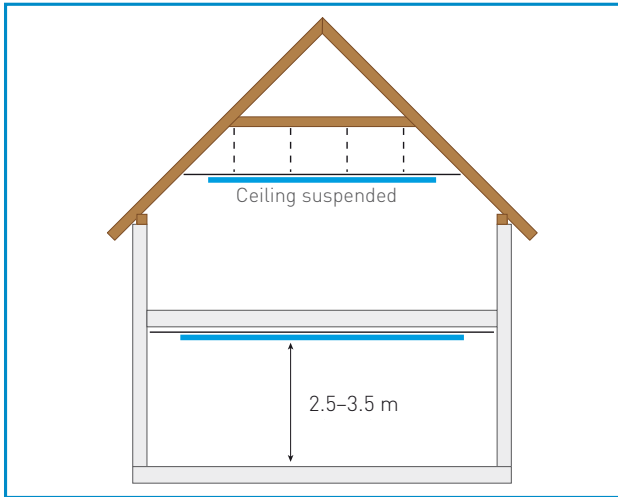

Guide values for dimensioning¹ the ModularCeiling:

50 to 60 % of the room floor area	70 to 80 % of the room floor area
+ Heating o Cosy cooling effect	+ Cooling + Heating + Energy saving due to lower flow temperature
Example, 20 m ² area:	Example, 20 m ² area:

If the ceiling is dimensioned for heating, experience has shown that it still achieves a good cooling effect if this surface is used for cooling in summer. Conversely, the flow temperature can be reduced in winter when heating if the ceiling area is dimensioned for cooling. This saves energy!

¹ Observe the heating/cooling load calculation for precise dimensioning of the area required!

ModularCeiling as a "ceiling sail"

Pay attention to the VarioModular pipes when fastening the ModularPanels in the edge areas (deviation from fastening area)!



▲ Example of a "ceiling sail"

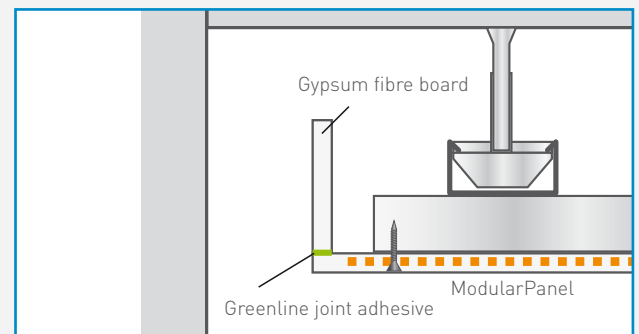

▲ Example: Execution of the edges

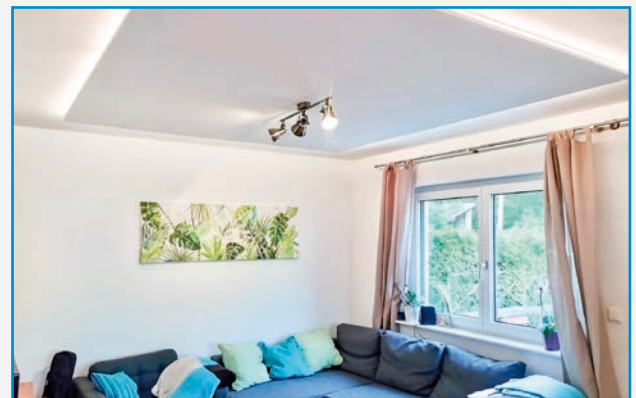

▲ Example of a "ceiling sail" with indirect lighting

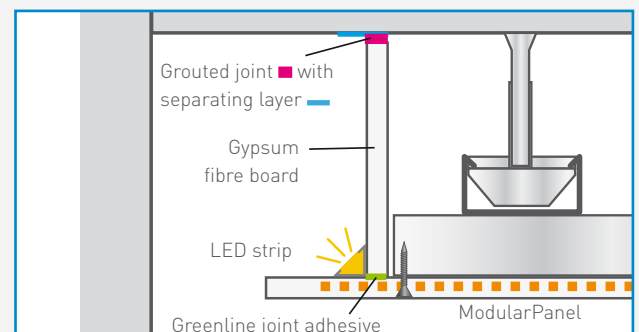

▲ Example: Execution of the edges with LED strip

9 PROTOCOLS

9.1 Leak-tightness test (in accordance with EN 1264-4)

After installation and before completion work (screeding, filling, painting, wallpapering), the circuits of the Variotherm ModularCeiling must be checked for leak-tightness by means of a water pressure test. The test pressure should be min. 4 bar and max. 6 bar. Due to the initial pipe expansion, it may be necessary to re-pump the test pressure. If there is a risk of freezing, appropriate measures should be taken, e.g. use of antifreeze and controlling the building's temperature.

The Leak-tightness test can also be carried out with compressed air as an alternative. The test pressure in this case is max. 3 bar.

Construction project: _____

Building owner/occupant: _____

Client: _____

Heating installer: _____

Architect: _____

Others: _____

- › Installation of ModularPanels finished on: _____
- › Installation of pipe connections finished on: _____
- › Leak-tightness is carried out with water compressed air
- › Pressure test started on: _____ with test pressure ____ bar
- › Pressure test finished on: _____ with test pressure ____ bar
- › Start of completion work (screeding, filling, painting, wallpapering etc.) on: _____
- › System pressure during the completion work was ____ bar
- › The system water was treated (e.g. per ÖNORM H 5195-1, VDI 2035) Yes No
- › Antifreeze was added to the system water Yes No
- › The system was checked for leak-tightness: _____ and approved

Approval:

Building owner/Occupant/Client

Construction management/Architect

Heating installer

9.2 Functional heating (in compliance with EN 1264-4 or BVF¹)

The functional heating serves as verification and proof of the creation of a defect-free installation for the heating installer and/or drywall builder.

The functional heating is only carried out after the filling or gluing work has been completed. The filler or joint adhesive must have hardened.

Manufacturer's instructions must be observed.

The maximum calculated flow temperature must be maintained for at least 1 day.

Construction project: _____

Building owner/occupant: _____

Client: _____

Heating installer: _____

Architect: _____

Others: _____

Preheating of the Variotherm ModularCeiling

- › Completion work finished: _____
- › Preheating started with constant max. calculated flow temperature: _____ | $t_f =$ _____ °C
- › End of functional heating : _____
If there is a risk of freezing, appropriate measures should be taken, (e. g. frost protection mode).
- › The rooms were ventilated without draughts and all windows and external doors closed after switching off the surface heating and cooling system: Yes No
- › Operating state and outdoor temperature on handover:

When switched off after the preheating phase, the ModularCeiling must be protected against draughts and from cooling down too quickly until it has cooled down completely.

Approval:

Building owner/Occupant/Client

Construction management/Architect

Heating installer

9.3 Commissioning

The flow temperature (heating water) of the ModularCeiling must not exceed $t_f = 50$ °C. The main stop valves at the distribution station and the heating circuit shut-offs must be opened. The entire system must be well vented. The circulation pump can be switched on after venting. After commissioning a Variotherm surface heating/cooling system can be considered maintenance-free.

(Subject to technical changes.)

¹ BVF = Bundesverband Flächenheizungen und Flächenkühlungen e.V.

ENJOY THE COMFORT & SAVE ENERGY

That's why our customers love us:
Heating and cooling optimised for COMFORT in all rooms!
Fast and friendly service, ANSWERS backed up with expertise!
Always in tune with the latest technology, INNOVATION guaranteed!
Everything CLEAR and SIMPLE, in writing of course!
PROFESSIONALISM at all times, from the first contact to the reference list!

VARIO THERM SINCE 1979

Variotherm is an Austrian model plant with hundreds of partners in Austria, Europe and around the world.



VBOOK4_EN | 11/2025

Your Variotherm Partner

VARIO THERM HEIZSYSTEME GMBH

GÜNSELSDORFER STRASSE 3A
2544 LEOBERSDORF
AUSTRIA

Phone: +43 [0] 22 56 - 648 70-0

office@variotherm.com www.variotherm.com

All rights pertaining to distribution and translation, in whole or in part, including film, radio, television, video recording, Internet, photocopying and reprinting, are reserved. Subject to mistakes and printing errors. Misprints and errors excepted.