

DESIGN & INSTALLATION

Manifold DISTRIBUTION AND CONTROL

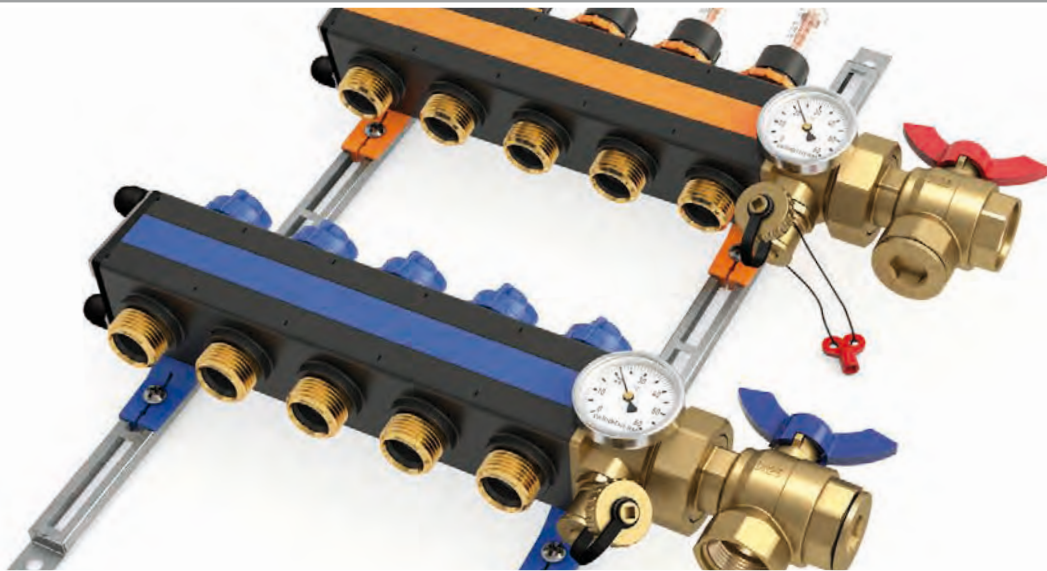

VBOOK9_EN | 8/2025

PDF



www.variotherm.com

VARIOTHERM

TABLE OF CONTENTS

1 GENERAL.....	3	5 CONTROLLERS	20
1.1 Safety information	3	5.1 Overview	20
1.2 Warranty conditions	3	5.2 Dew-point monitoring/sensor DPS.....	21
1.3 Standards.....	3		
1.4 System layouts.....	3	6 PUMPED VARIOMANIFOLD	22
2 MANIFOLD CABINETS.....	6	6.1 Description	22
2.1 Manifold cabinet on-wall.....	6	6.2 Examples for power and volume flow.....	23
2.2 Manifold cabinet UF in-wall	7	6.3 Pump PVS (TacoFlow3 15–60)	23
2.3 Direct wall/ceiling mounting.....	9	6.4 Regulating valve – Pressure loss in the primary circuit ...	23
2.4 Installation depth of the manifold systems.....	9	6.5 WHR36 – weather-guided controller	24
2.5 Installation on C-rails/fixing bars	9	6.6 Mounting positions	25
		6.7 Troubleshooting.....	25
3 VARIOMANIFOLD 5.0	10	7 PUMP MICROSTATION	26
3.1 Description	10	7.1 Description	26
3.2 3 port valve.....	11	7.2 Examples for power and volume flow.....	27
3.3 Completion of the connecting block.....	11	7.3 Pump PMS (TacoFlow3 15–60)	27
3.4 Examples for dimensioning the supply pipes	11	7.4 Regulating valve – Pressure loss in the primary circuit ...	27
3.5 Spacer for bracket set.....	12	7.5 WHR36 – weather-guided controller	28
3.6 Flow characteristic curve	12	7.6 Mounting positions	29
3.7 Possible variations	13	7.7 Troubleshooting.....	29
3.8 Connecting the Variotherm pipes.....	14		
3.9 Filling/flushing/venting the system	14	8 RETURN TEMPERATURE LIMITER	30
3.10 Leak-tightness test.....	15		
3.11 Hydronic balancing	16		
3.12 Clean/replace sight glass.....	17		
3.13 Replacing the valve with the Duo tool	17		
4 ACTUATOR	18		
4.1 Actuator	18		
4.2 Actuator with limit switch	18		
4.3 Installing the actuators	19		
4.4 Functionality description with limit switch	19		

1 GENERAL

1.1 Safety information

- › The electrical and hydraulic connection and service work on the device may only be provided by authorised specialist personnel.
- › The devices are designed for use in dry, closed rooms.
- › The electrical installation standards and regulations specified by the local energy supply companies should be observed, together with the locally applicable regulations and standards for heating installations.
- › Faults in the connection can cause damage to the device! We bear no liability for damage caused by incorrect connection and/or inappropriate handling of the device.

This brochure (version dated 8/2025) is intended for authorised qualified personnel and constitutes part of our warranty!

All previous versions become invalid upon release of a new version! For the latest version please refer to the QR Code on the title page or www.variotherm.com. Local, geographic and climatic regulations/standards for cooling, heating and electrical installations must be observed!

1.3 Standards

The validity of the standards specified in these installation instructions was last verified on 2 July 2025. If necessary, amendments to standards must be checked!

1.2 Warranty conditions

If installed or commissioned incorrectly, all claims on the basis of the manufacturer's warranty and guarantee become void.

1.4 System layouts

The following system layouts serve as examples, but are by no means exhaustive!

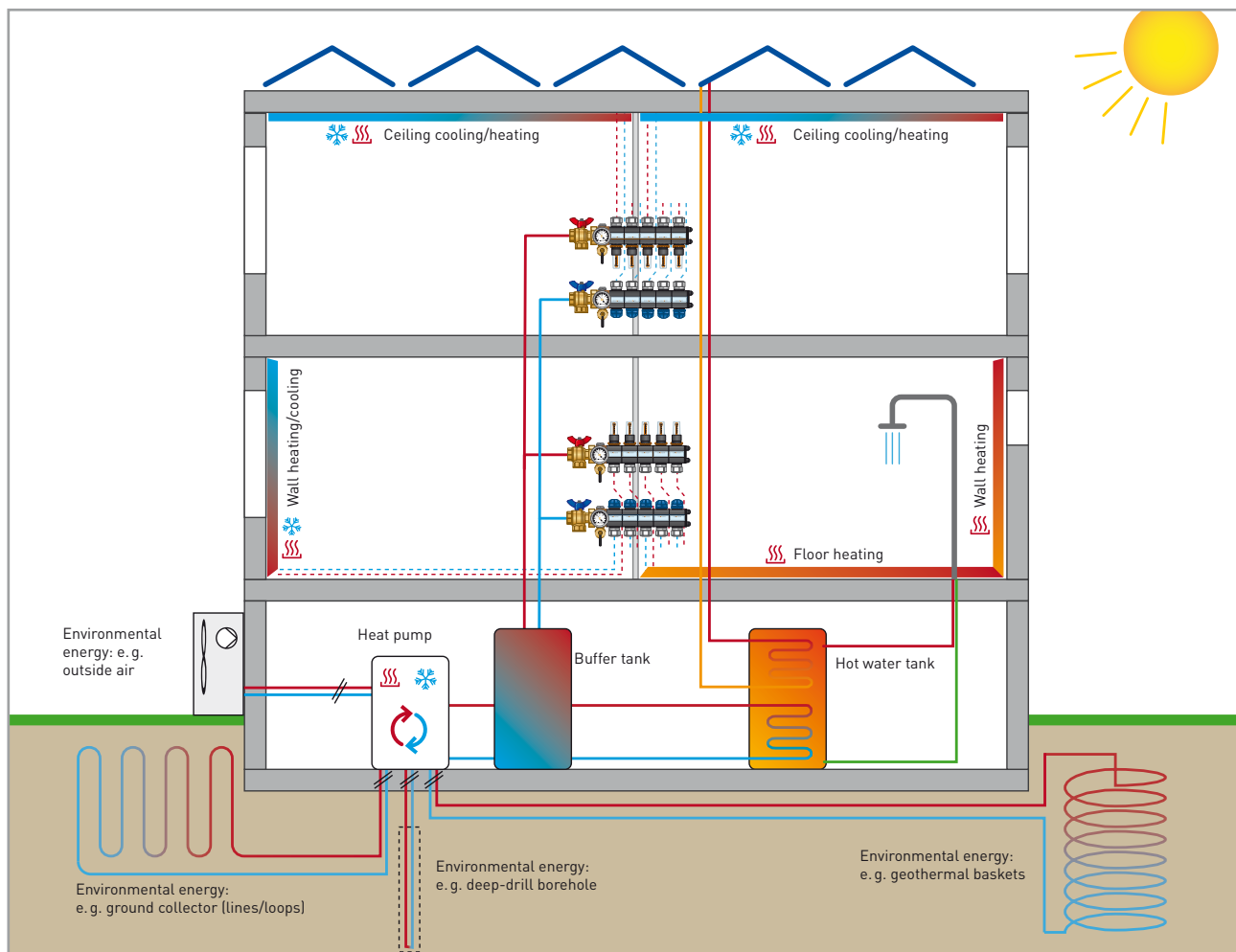

▲ Example scheme in combination with heat pump variants

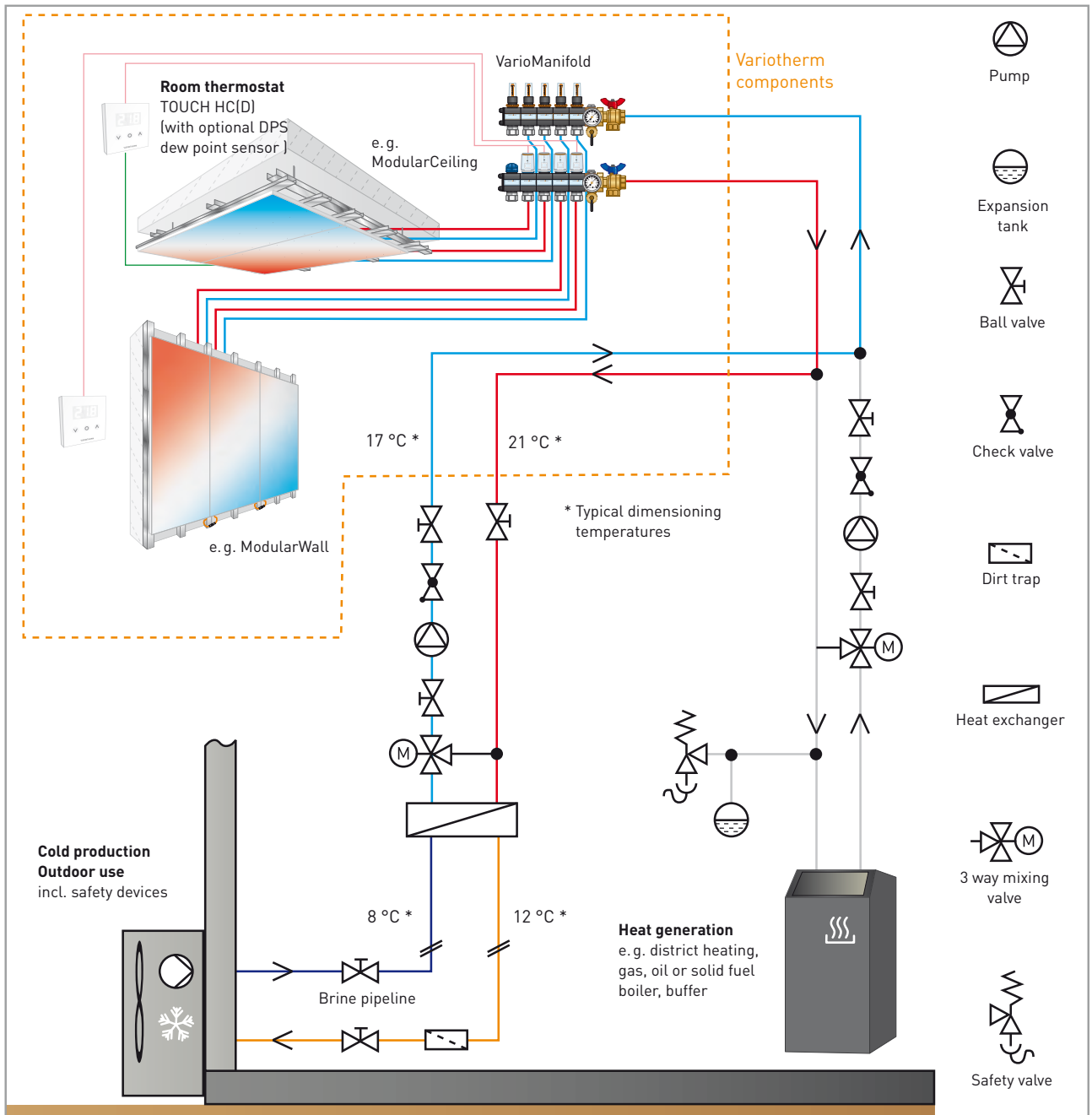

▲ Example of active cooling (not intended to be exhaustive!)

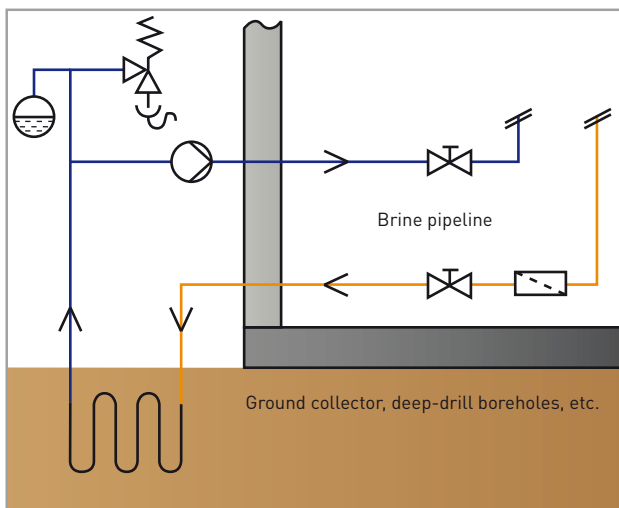

▲ Example of passive cooling (not intended to be exhaustive!)

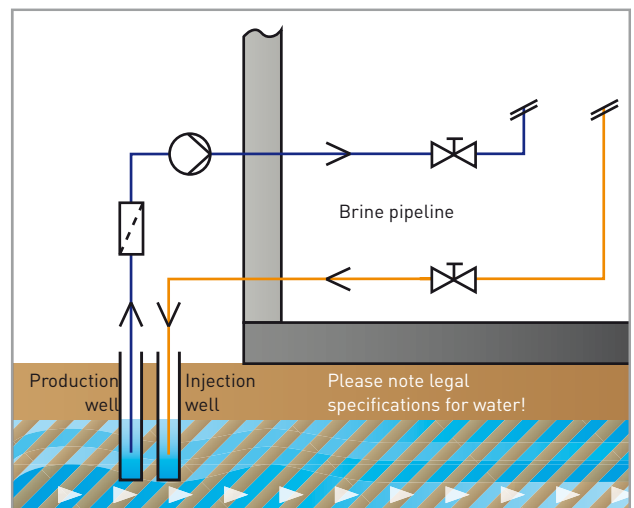

▲ Example of passive cooling (not intended to be exhaustive!)

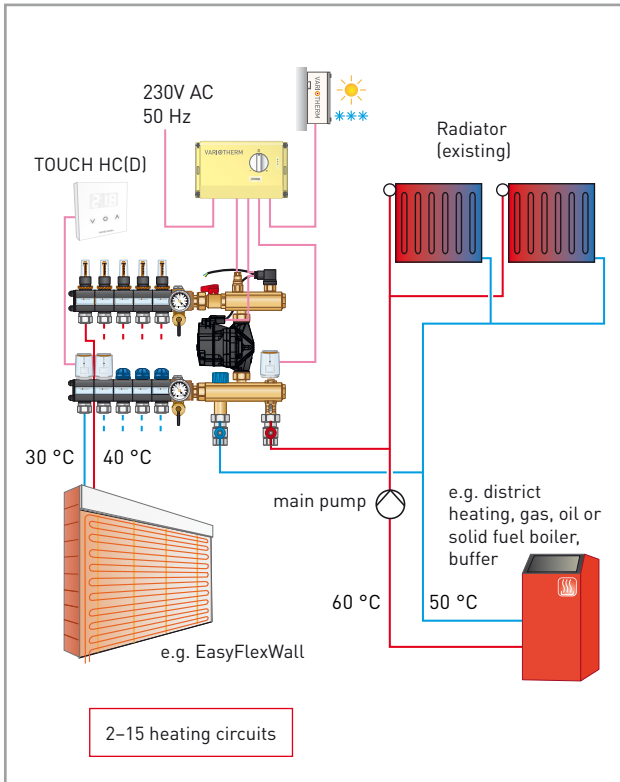

▲ Pumped VarioManifold (weather-guided)

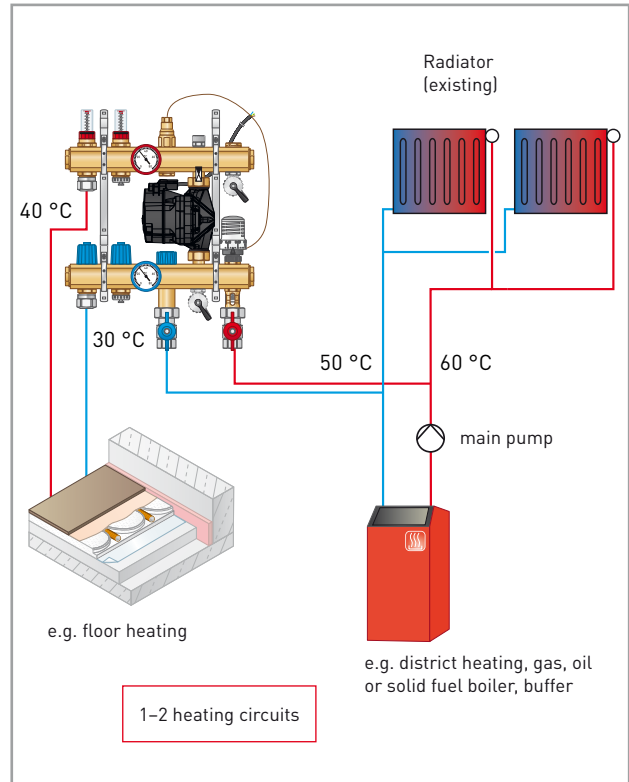

▲ Pump Microstation and fixed-value regulator

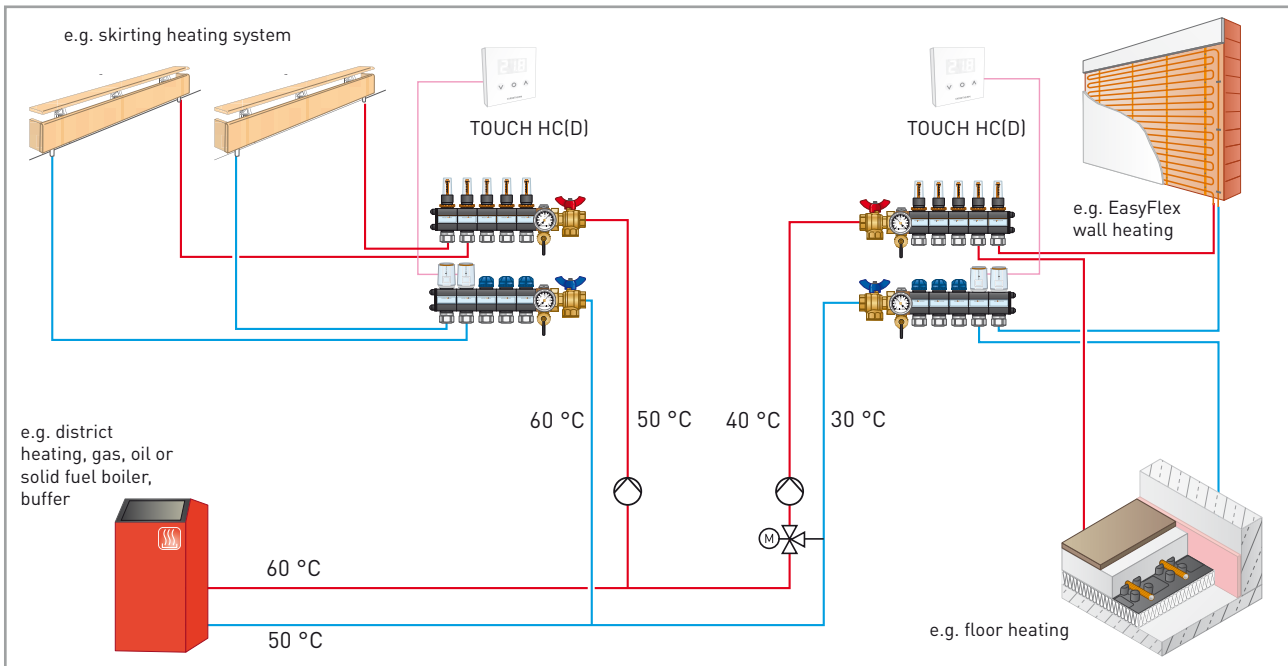

▲ System with 2 temperature circuits (heating)

2 MANIFOLD CABINETS

2.1 Manifold cabinet on-wall

The manifold cabinet is placed on the wall and screwed tight. For the bracket installation, see section 2.5.

Technical drawing showing manifold cabinet types (VSA1, VSA2, VSA3, VSA4) with dimensions and labels. Labels include: Slot for cable entry, Fixed back panel, C-rails, Front door, Screed facing, and Dimension B. Dimensions shown: 125 mm, 19 mm, 565 mm, 465 mm, 100 mm, and 0 - 180 mm.

Manifold cabinet types (Part. No.)	VSA1	VSA2	VSA3	VSA4
Dimension B (mm)	452	652	952	1252
Weight	5.7 kg	7.4 kg	13.0 kg	15.8 kg
VarioManifold circuits	2-3	1, 4-7	8-13	14-17
Pumped VarioManifold circuits	-	2-6	7-12	13-15
Pump Microstation circuits	1-2	-	-	-

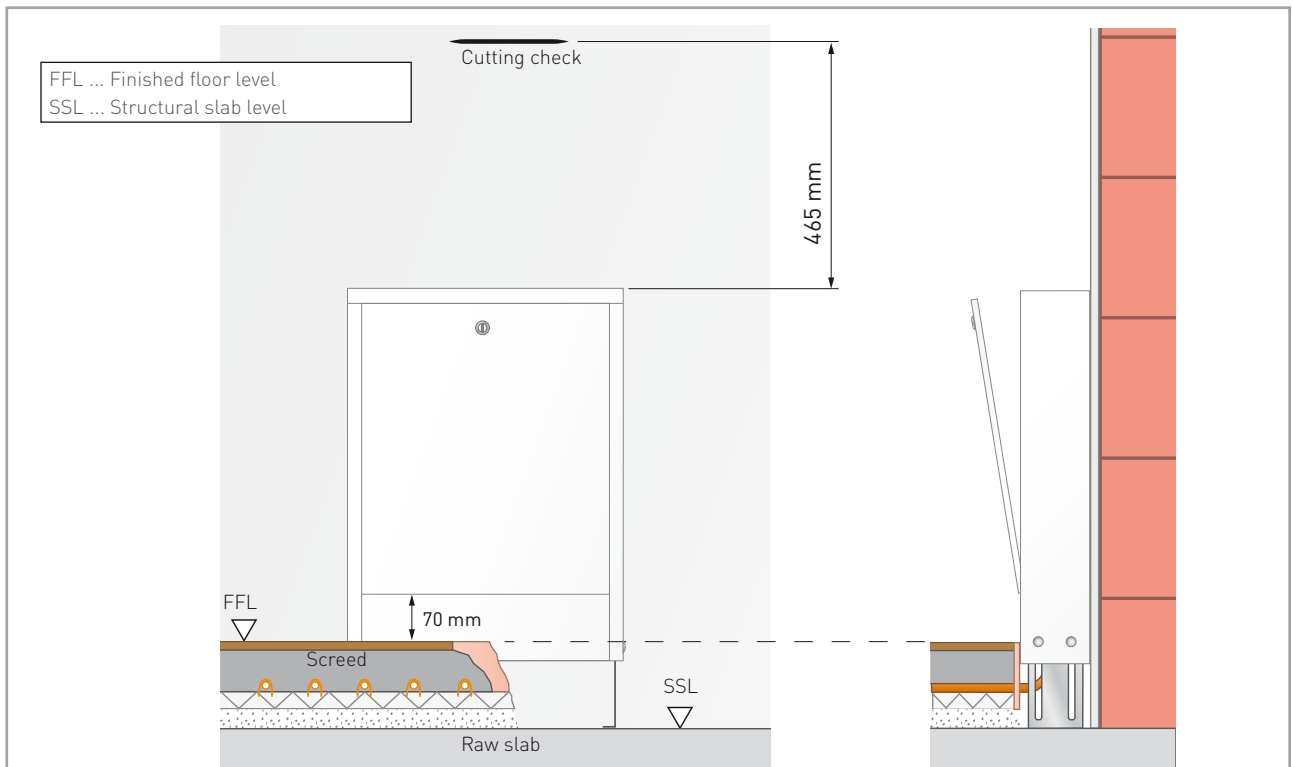

▲ Example for on-wall installation

2.2 Manifold cabinet UF in-wall

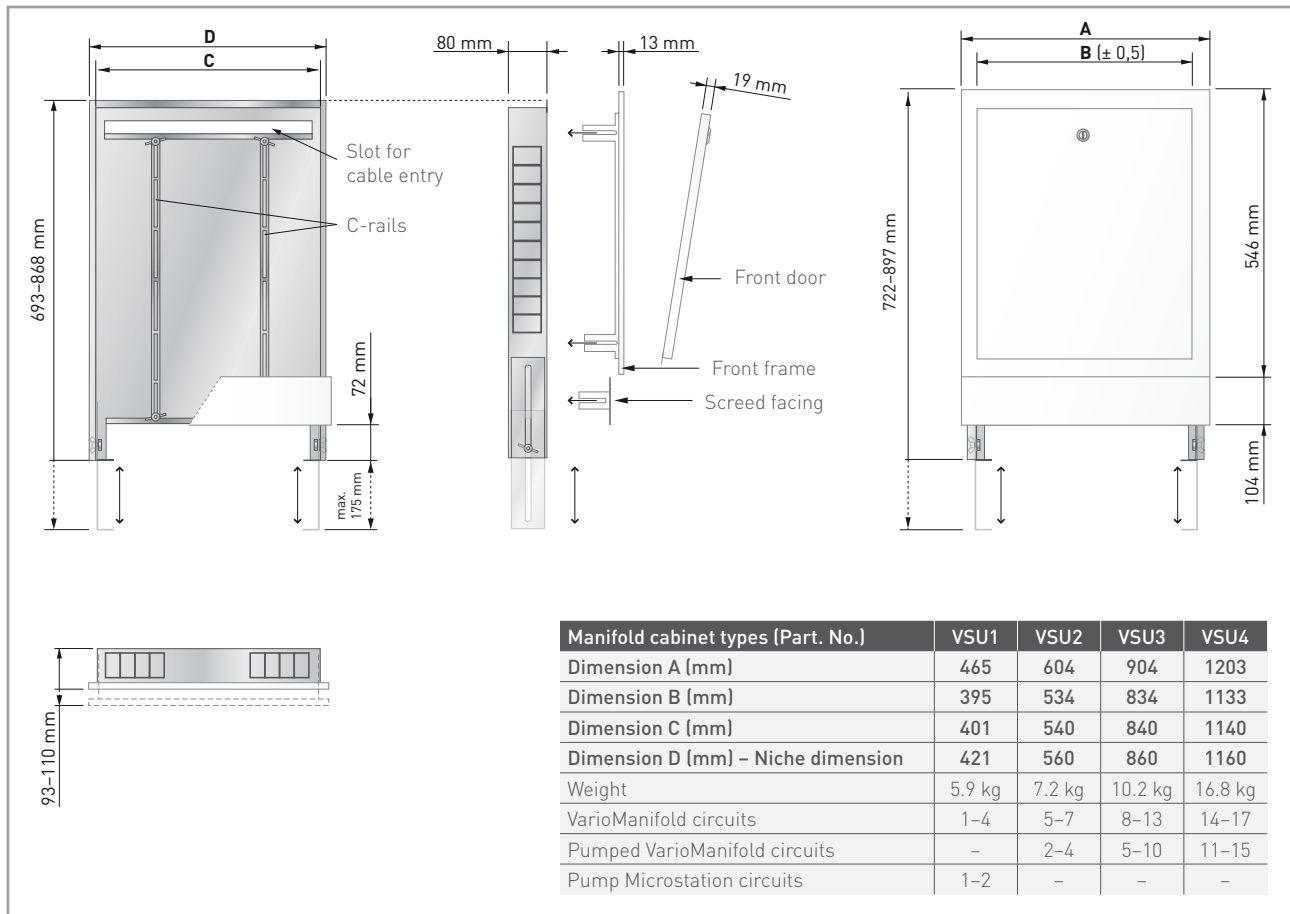

Installation

1. Remove the front frame and the base cover from the cabinet.
2. Place the cabinet in the recess in the wall, straighten it using the adjustable feet and fix it to the unfinished floor.
3. Mount the bracket set to the rear side of the manifold.
4. Snap the VarioManifold into the C-rails and affix with the screws.
5. Connect the connection pipes. Pre-cut opening plates at the sides or top can also be removed if required for this purpose.
6. Fix the wall cabinet in the wall with e.g. polyurethane foam (low curing pressure). Screw it to the supporting structure in the drywall.
7. Lay out the heating/cooling distribution circuits.

In-wall mounted front frame:

- 8a. Insert the enclosed plaster protection (cardboard) into the wall cabinet. Cover all visible parts well (e.g. with painter's tape).
- 9a. After completing the wall, remove the protective coverings or adhesive tapes and attach the doors.

Wall-mounted front frame:

- 8b. Insert the enclosed plaster protection (cardboard) into the wall cabinet. Align the front box edge to the finished plaster edge or finished wall edge. Cover all visible parts well (e.g. with painter's tape).
- 9b. After completing the wall, remove the protective coverings or adhesive tapes and attach the front frames and doors.

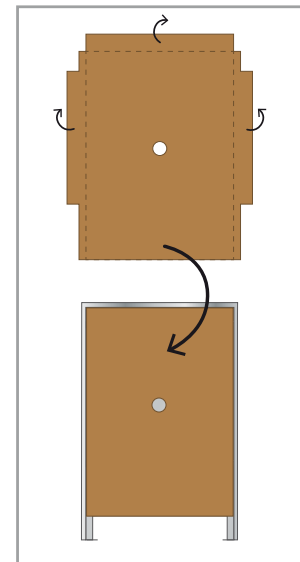

▲ Plaster protection for cabinet

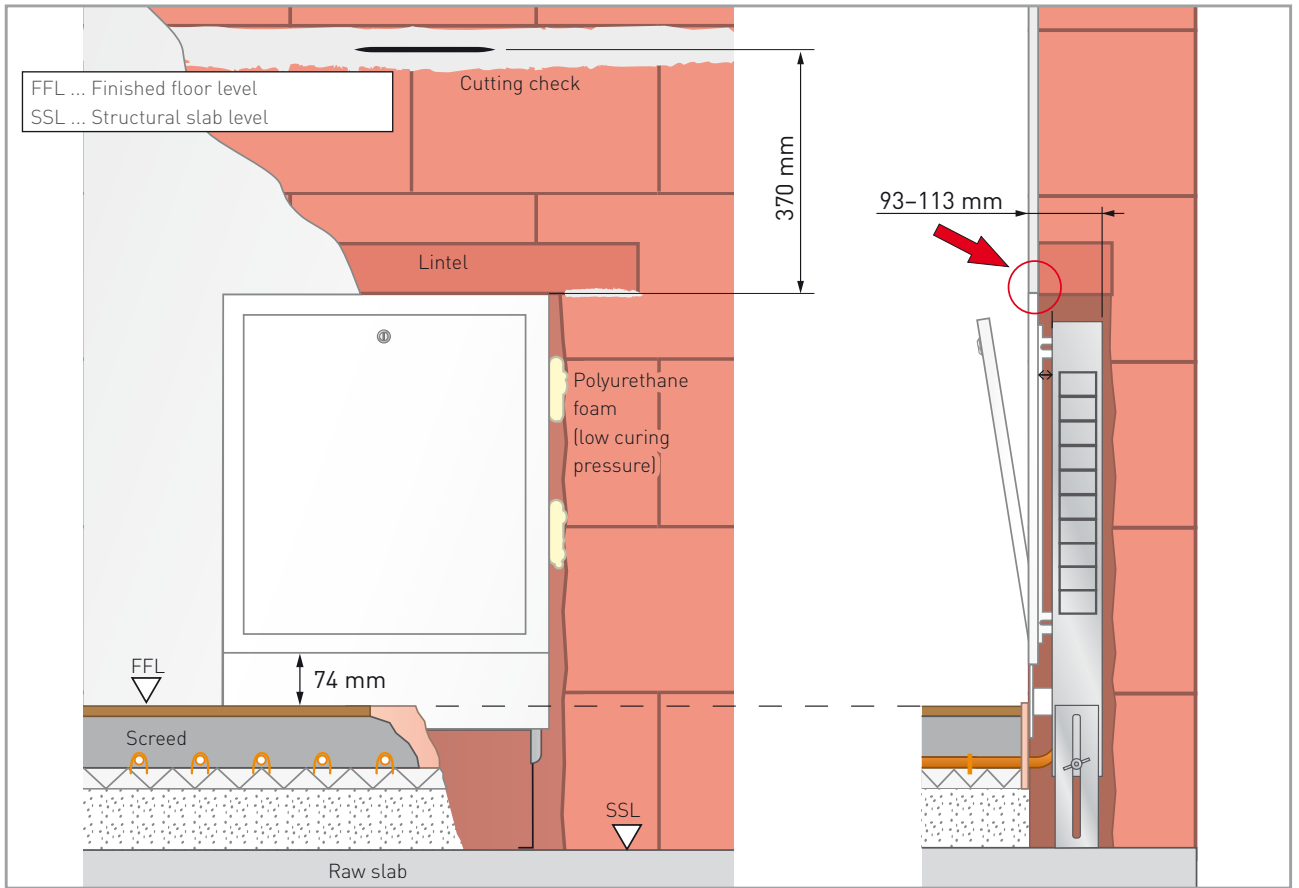

▲ Example for in-wall mounted front frame

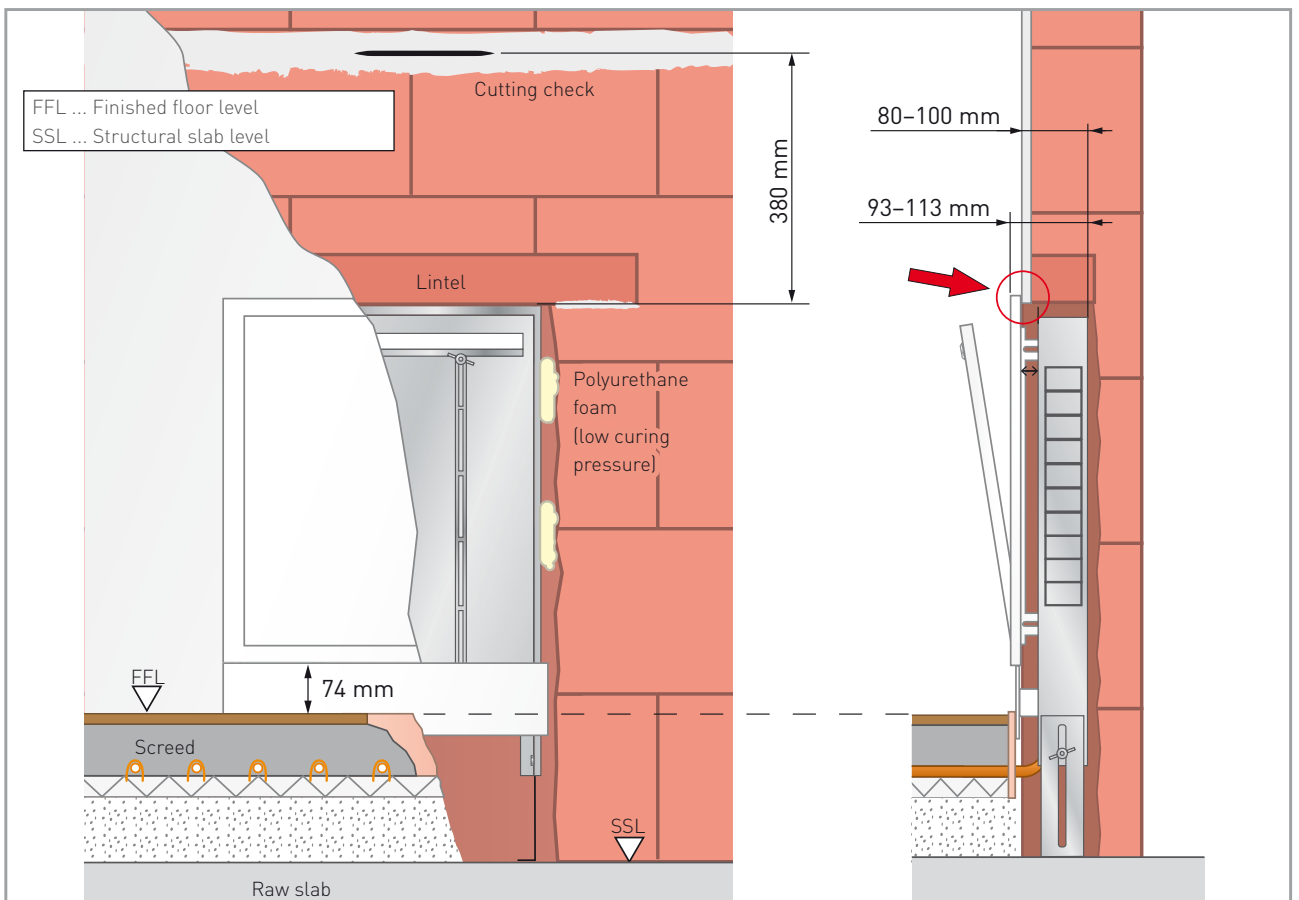

▲ Example for wall-mounted front frame

2.3 Direct wall/ceiling mounting

The fixing bars are mounted with the screws provided leaving a suitable space to the wall or ceiling depending on the size of the manifold. The VarioManifold 5.0 or Pumped VarioManifold 5.0 can then be fixed to this.

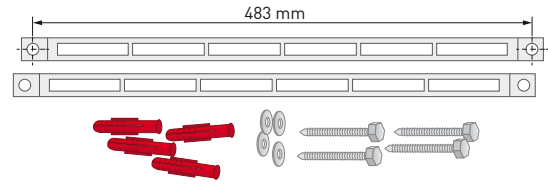

▲ Part No.: VT545

2.4 Installation depth of the manifold systems

VarioManifold 5.0

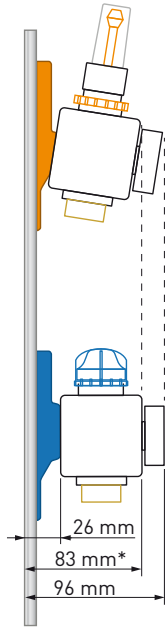

* without thermometer

Pumped VarioManifold



Pump Microstation

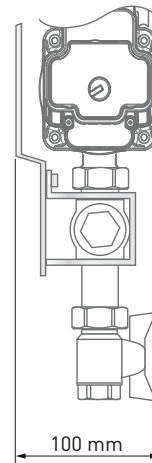

▲ see also spacer, chapter 3.5

2.5 Installation on C-rails/fixing bars

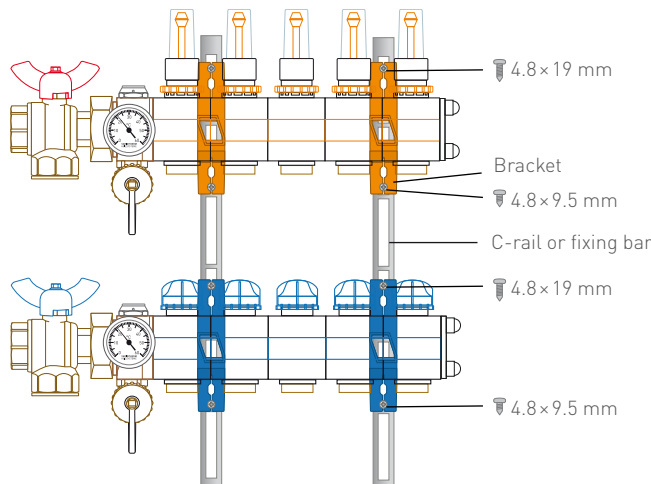
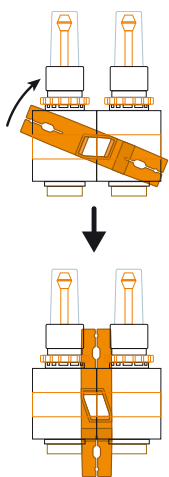

Demounting:

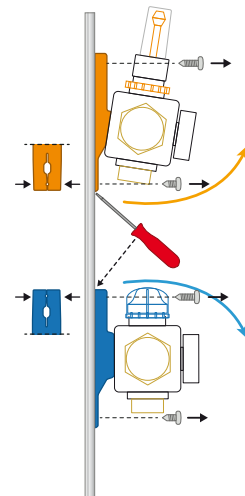

3 VARIOMANIFOLD 5.0

3.1 Description

The VarioManifold 5.0 is made of plastic modules which are fitted together according to the number of heating/cooling circuits required.

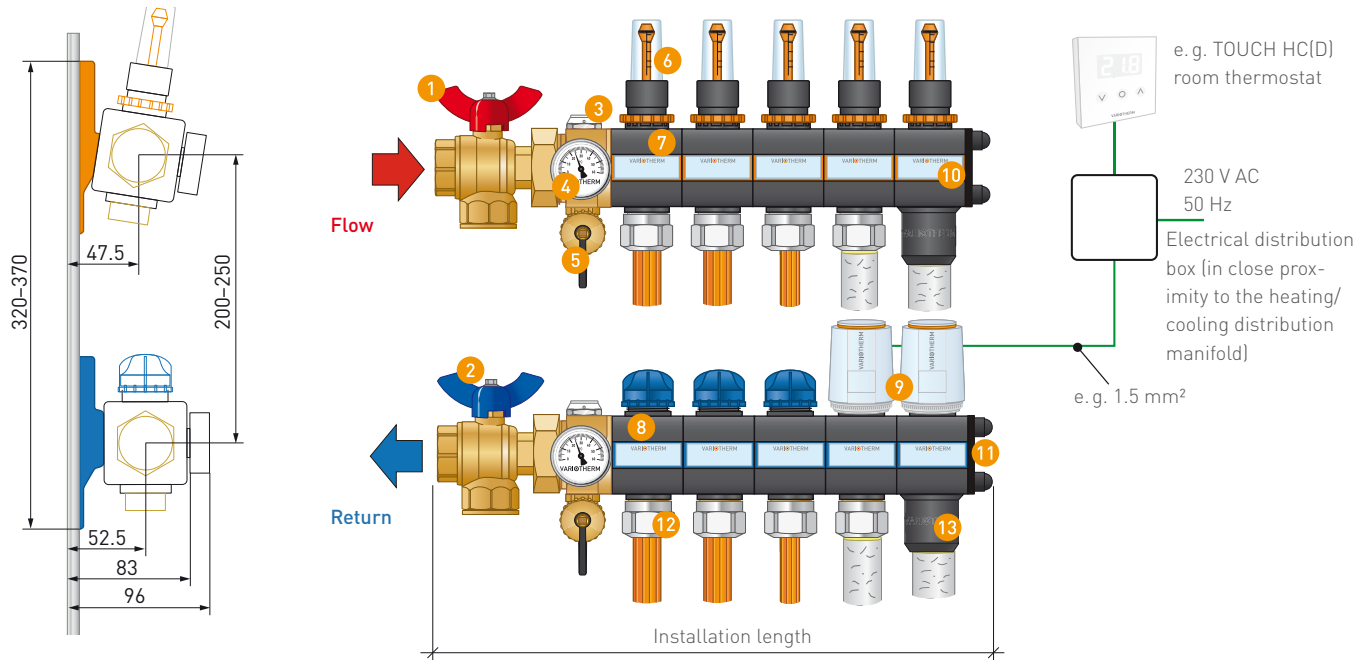

Manifold circuits	Installation length	Fitting manifold	Remaining space VSU/VSA
1 circuit*	345 mm	VSU1/VSA2	50/305 mm
2 circuits	245 mm	VSU1/VSA1	150/205 mm
3 circuits	295 mm	VSU1/VSA1	100/155 mm
4 circuits	345 mm	VSU1/VSA2	50/305 mm
5 circuits	395 mm	VSU2/VSA2	139/255 mm
6 circuits	445 mm	VSU2/VSA2	89/205 mm
7 circuits	495 mm	VSU2/VSA2	39/155 mm
8 circuits	545 mm	VSU3/VSA3	289/405 mm
9 circuits	595 mm	VSU3/VSA3	239/355 mm
10 circuits	645 mm	VSU3/VSA3	189/305 mm
11 circuits	695 mm	VSU3/VSA3	139/255 mm
12 circuits	745 mm	VSU3/VSA3	89/205 mm
13 circuits	795 mm	VSU3/VSA3	39/155 mm
14 circuits	845 mm	VSU4/VSA4	289/405 mm
15 circuits	895 mm	VSU4/VSA4	239/355 mm
16 circuits	945 mm	VSU4/VSA4	189/305 mm
17 circuits	995 mm	VSU4/VSA4	139/255 mm

* 1-block variant

Technical data

Max. test pressure: 10 bar (only with water)

Max. operating overload pressure: 6 bar

Operating temperatures: -20 bis +90 °C (anti-freeze filling)

Installation depth of manifold:

96 mm or 83 mm with removed thermometers

Max. flow rate of the manifold: 3500 l/h (3.5 m³/h)

- 1 Flow 3 port valve incl. blank fitting (Connections: 1" female thread)
- 2 Return 3 port valve incl. blank fitting (Connections: 1" female thread)
- 3 Manual air vent 4 Thermometer 5 Fill & drain cock 1/2", twistable
- 6 Flow indicator, viewing glass can be unscrewed under pressure
- 7 Flow segment with flow indicator which can be pre-set (10-160 l/h)
- 8 Return segment with shut-off valve
- 9 Thermoelectric actuator (for individual room regulation)
- 10 Identification labels 11 End panel (insulated)
- 12 Variotherm clamping screw fitting 3/4" Eurocone (For Variotherm pipes \varnothing 11.6, \varnothing 16 and \varnothing 20 mm)
- 13 Insulating grommet (optional for cooling)

Advantages

- Plastic manifold with internal air chambers for heat insulation
- Flexible to convert to thermostat operation
- Pre-set flow indicator in the flow (10-160 l/h) according to EN 1264-4, viewing glass can be cleaned
- Optimised for **low temperature** surface heating/cooling
- Detachable 3 port valves on the flow and return
- Ventilation and flushing option via the twistable fill & drain cock
- Modular structure
- Completely oxygen-tight
- Identification labels
- All parts self-sealing, manifolds pressure-tested
- Adjustable spacing between the flow and return pipes

3.2 3 port valve

The VarioManifold is delivered ex-factory with a 3 port valve. This offers a number of possibilities for connecting the supply. The connection not used is closed with the blank plugs provided.

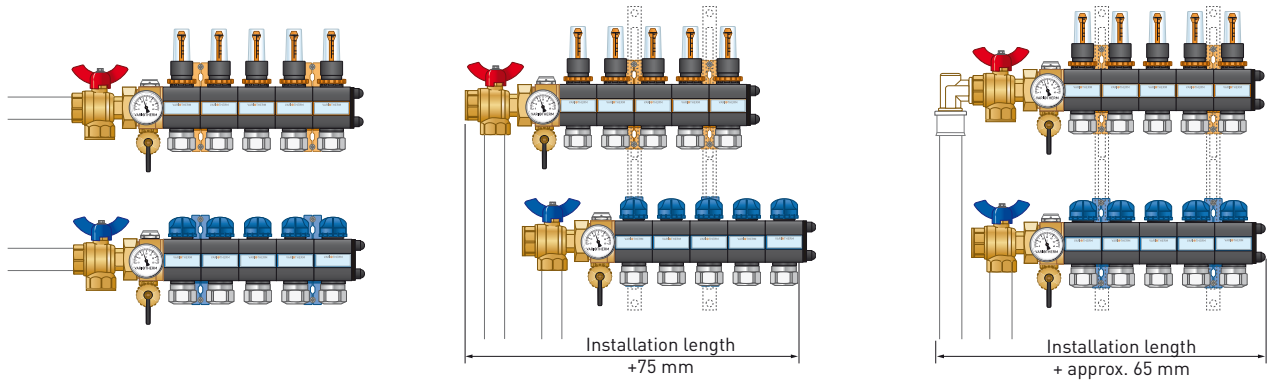

3.3 Completion of the connecting block

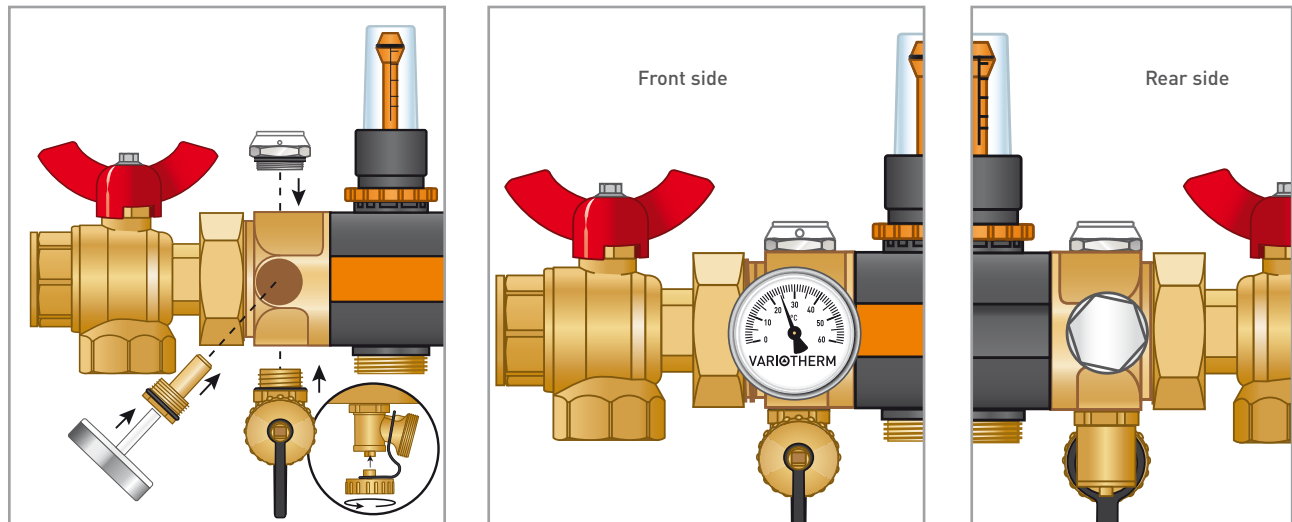

3.4 Examples for dimensioning the supply pipes

Dimensioning example for supply pipe to heating distribution manifold $\Delta t (t_f - t_r) = 10 \text{ K}$		
Heating circuit	Heat load	multi-layer supply pipes / copper / steel
≤ 6	≤ 7.5 kW	For example 26×3 / Cu22×1.0 / DN 20 (¾")
7-11	7.5-13 kW	For example 32×3 / Cu28×1.5 / DN 25 (1")
12-17	13-20 kW	For example 40×4 / Cu35×1.5 / DN 32 (1 ¼")
Dimensioning example for supply pipe to cooling distribution manifold $\Delta t (t_f - t_r) = 4 \text{ K}$		
Cooling circuit	Cooling load	multi-layer supply pipes / copper / steel
≤ 6	≤ 3.0 kW	For example 26×3 / Cu22×1.0 / DN 20 (¾")
7-11	3.0-5.5 kW	For example 32×3 / Cu28×1.5 / DN 25 (1")
12-17	5.5-9.5 kW	For example 40×4 / Cu35×1.5 / DN 32 (1 ¼")

3.5 Spacer for bracket set

For increasing the space between wall and manifold beam of the VarioManifold.
 +10 mm with one spacer (recommended for a pipe diameter of 16 mm)
 +20 mm with two spacers (recommended for a pipe diameter of 20 mm)



▲ Part No.: VT542

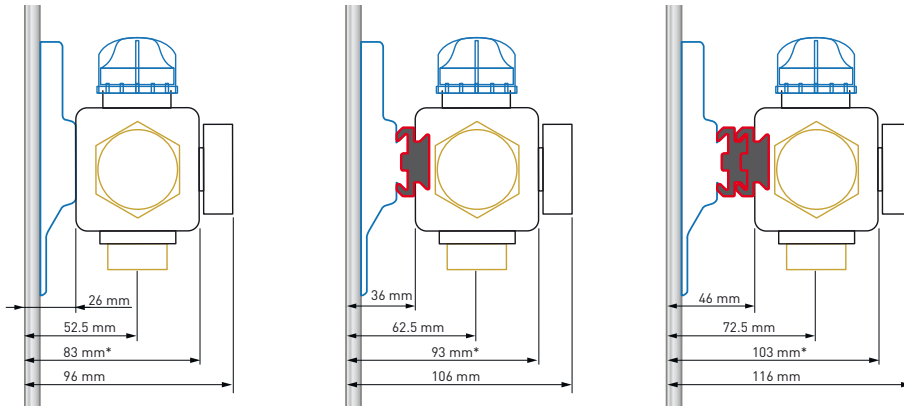

* without thermometer

3.6 Flow characteristic curve

To ascertain the pressure loss of the heating/cooling distribution manifold for the respective heating/cooling circuits (without pressure loss of pipes).

Max. opened return valve.

- With clamping screw fitting for VarioProFile pipe 11.6x1.5
- With clamping screw fitting for VarioProFile pipe 16x2

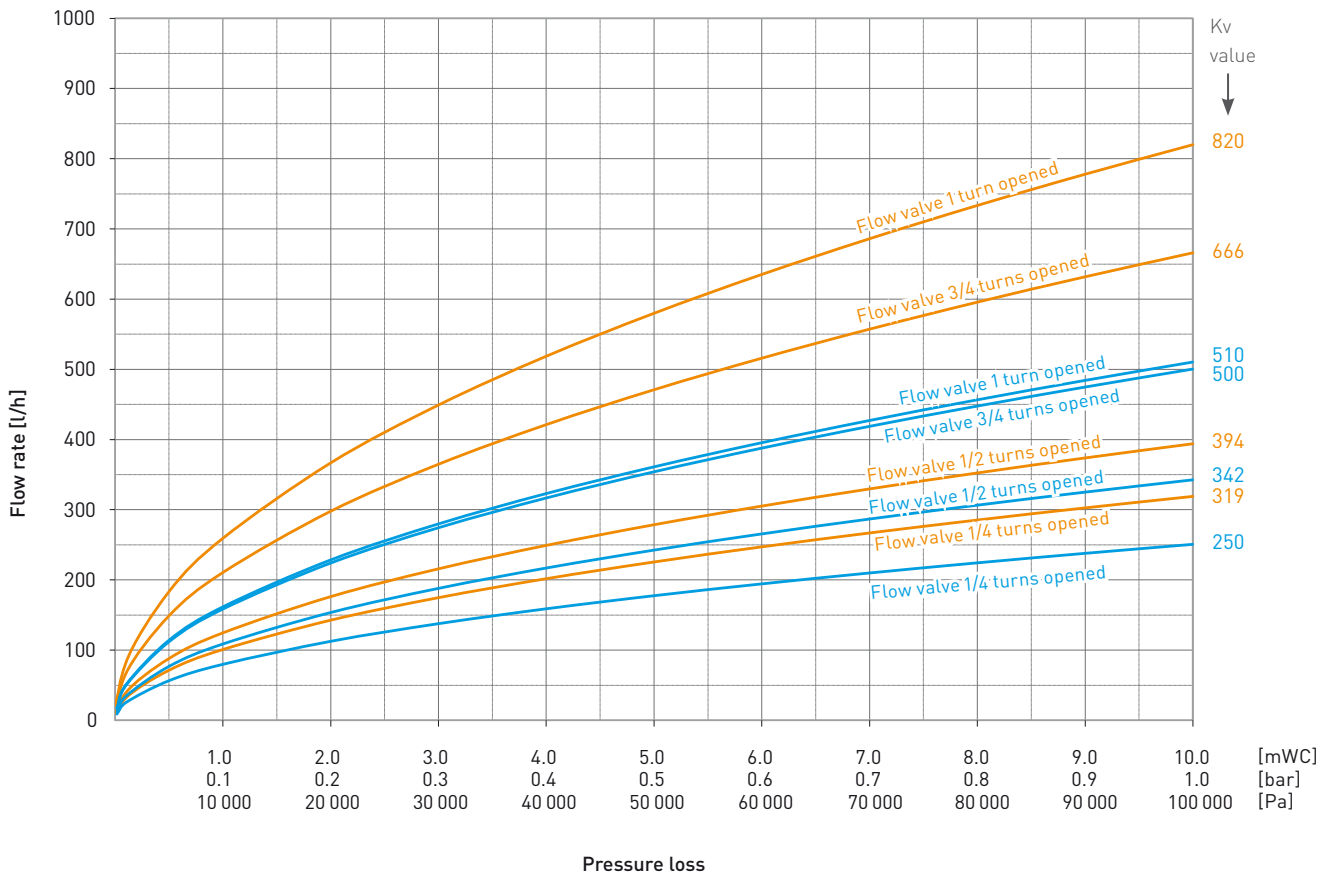
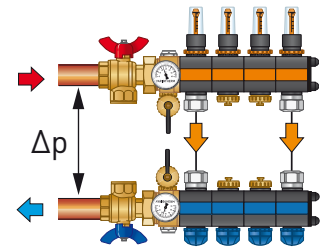

3.7 Possible variations

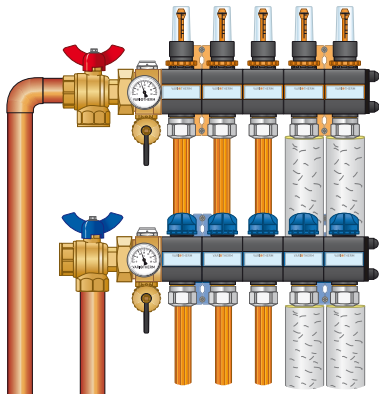

Basic Version

Example:
5 low-temperature circuits with floor heating system and wall heating system

Combination – two different temperature circuits

Example: 6 low-temperature circuits with wall and floor heating, 2 high-temperature circuits for trench heating and cosy corner bench

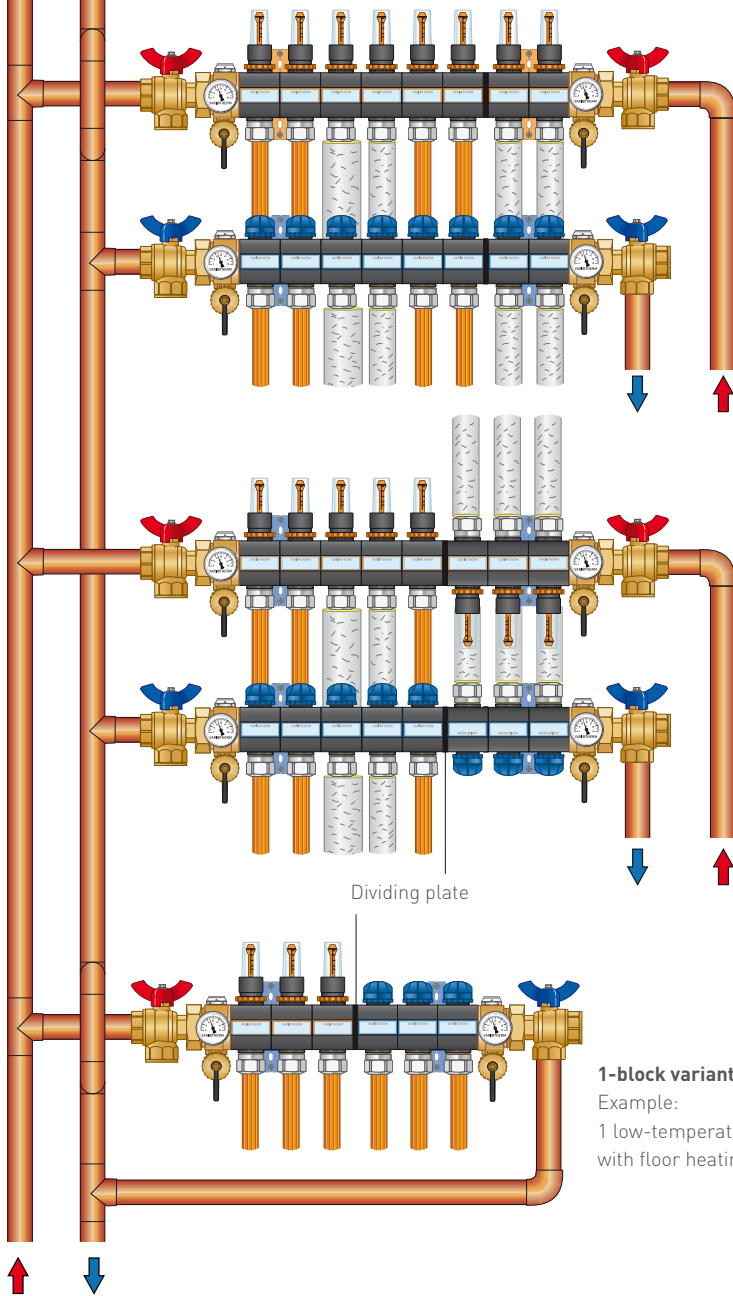

Example diagram:

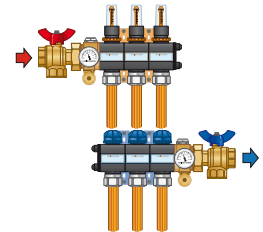
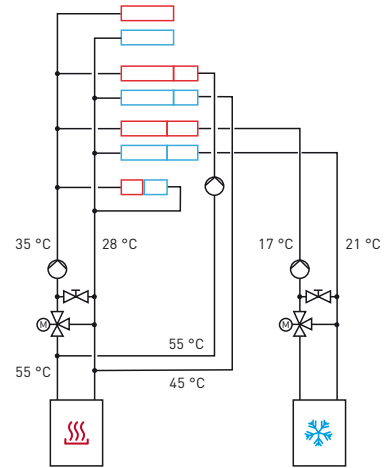

Flow connected to the left, return to the right

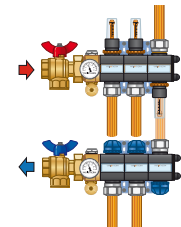

One circuit facing upwards

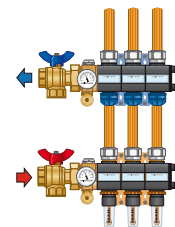

All circuits facing upwards

Combination – two different temperature circuits

Example: 5 heating circuits for floor heating, 3 cooling circuits for ceiling cooling

1-block variant

Example:
1 low-temperature circuit with floor heating system

- > Calibration and chamfering tool
- > Part No.: W042
- > PKU: 1 pce.
- > Weight/PKU: 140 g
- > For calibrating and chamfering the Variotherm pipes

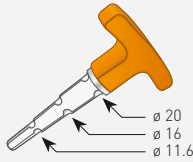

- > Pipe cutting pliers
- > Part No.: W037
- > PKU: 1 pce.
- > Weight/PKU: 230 g
- > For trimming the Variotherm pipes
- > Replacement blade: W0371



- > Clamping screw fitting 3/4"EUROx11.6
- > Part No.: Z1300
- > PKU: 1 pce.
- > Weight/PKU: 90 g
- > for VarioProFile pipe 11.6x1.5

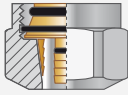

- > Clamping screw fitting 3/4"EUROx16
- > Part No.: Z1400
- > PKU: 1 pce.
- > Weight/PKU: 80 g
- > for VarioProFile pipe 16x2 and pre-insulated VarioModular pipe 16x2

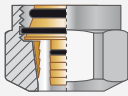

- > Clamping screw fitting 3/4"EUROx20
- > Part No.: Z1500
- > PKU: 1 pce.
- > Weight/PKU: 70 g
- > for VarioModular pipe 20x2

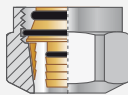

Clamping screw fitting: Especially developed for Variotherm pipes, nickel plated, single-piece, with metal clamping ring and galvanic isolation, tested according to EN 21 003

- > Insulating grommet
- > Part No.: VT68
- > PKU: 1 pce.
- > Weight/PKU: 15 g
- > protection against condensation at the clamping screw fitting in case of cooling



3.8 Connecting the Variotherm pipes

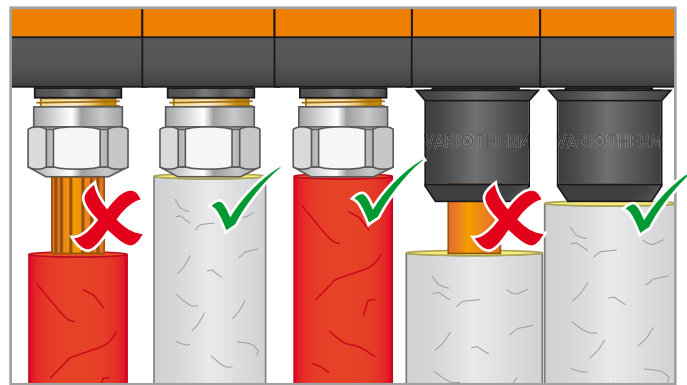
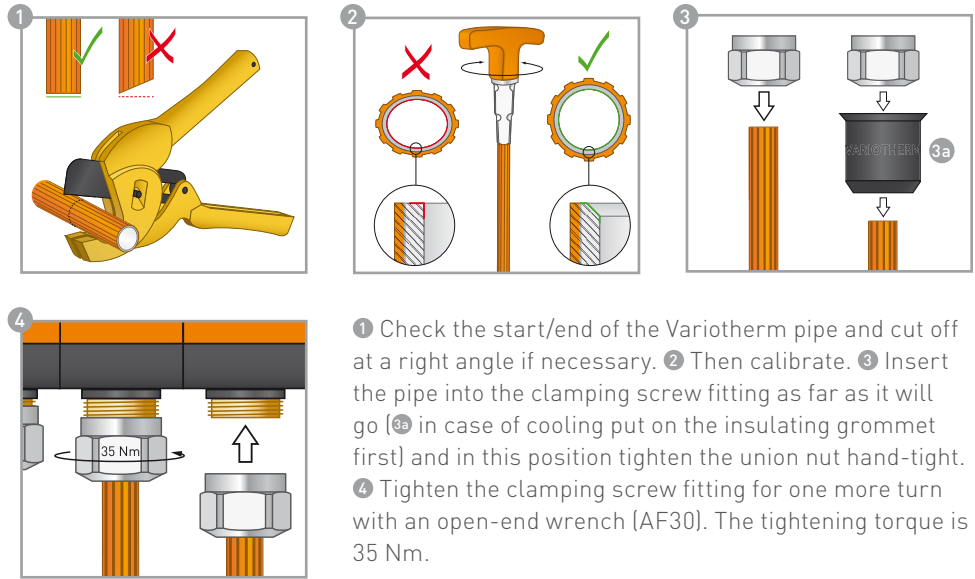

▲ Correct connection with pre-insulated pipe or insulating hose

3.9 Filling/flushing/venting the system

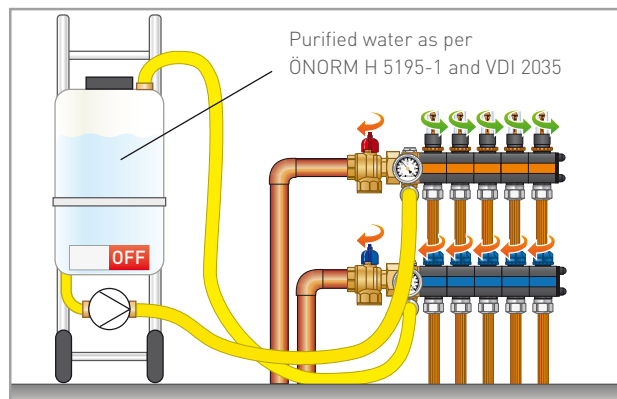

1. Main locking ball valves and all return modules are closed
2. All flow valves are opened
3. Then connect the filling and flushing station to both fill & drain cocks on the supply and return pipes.

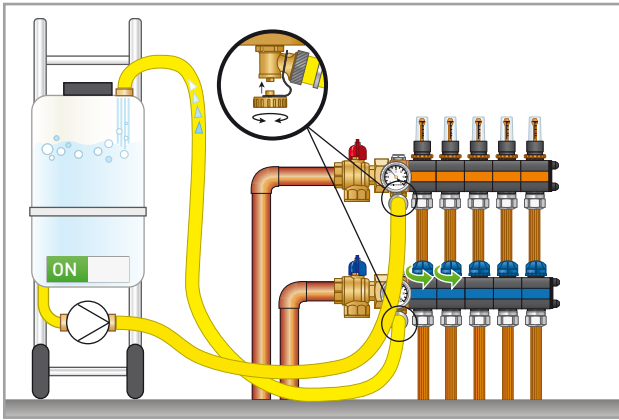

4. Switch on the flushing and filling station. Then open the fill & drain cock, the flow pipe is pressurised and the return segments of the first two heating/cooling circuits will open. This thoroughly flushes water through the flow into the heating/cooling circuits.

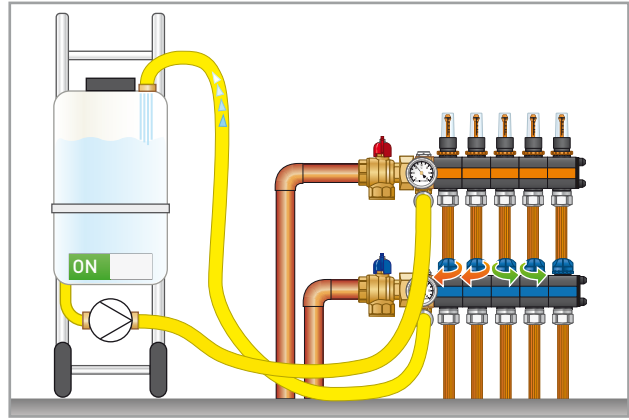

5. Once the water comes out with no air bubbles, the opened return modules are to be closed.

6. Immediately afterwards, the next two return modules are to be opened.

The same procedure is followed for the other circuits in sequential order, until the entire system is filled.

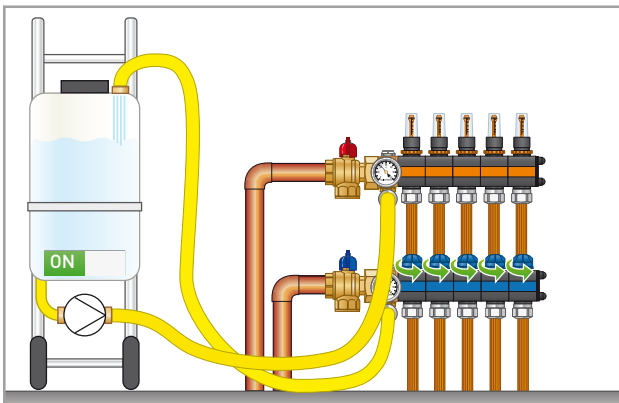

7. Finally, this "flushing procedure" is repeated upon opening of all flow and return modules.

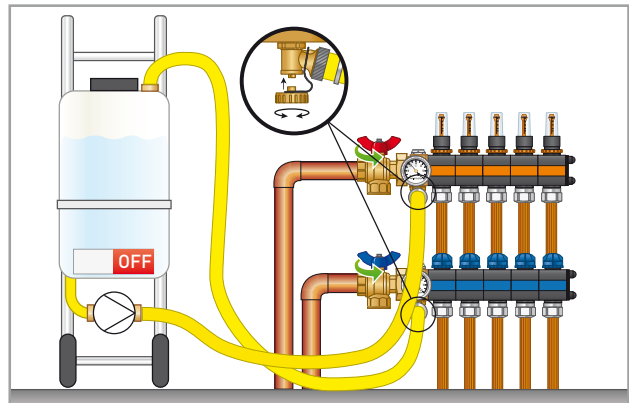

8. First turn off the fill & drain cock on the return pipe, then immediately turn off the fill & drain cock on the flow pipe. Turn off the flushing and filling station. Open the main locking ball valves.

3.10 Leak-tightness test

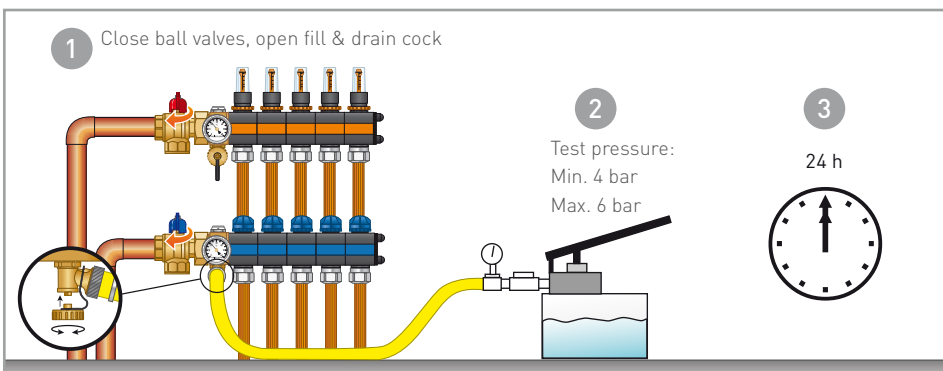

3. Maintain test pressure for 24 hours. Then tighten the screwed fittings and reduce pressure to 2-3 bar. Maintain this pressure until completion of the object in order to identify any possible damage.

3.11 Hydronic balancing

The length of the Variotherm pipe (heating surface + supply pipes), possible connection parts (e.g. press-fit couplings) and the distribution manifold determine the pressure loss in the individual heating/cooling circuits. For hydronic balancing, the relevant circulation pump must be running. A water flow rate is assigned to each heating/cooling circuit.

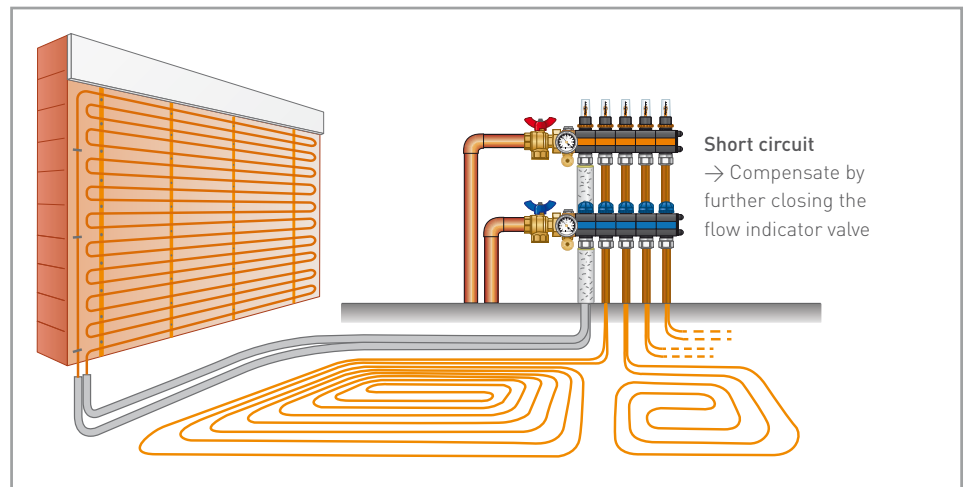

Hydronic balancing is performed by means of the flow rate valve in the flow (orange segment).

The fixing ring

According to EN 1264-4, it must be possible to use the shut-off and balancing functions independently of each other.

The orange fixing ring can be used to "memorize" the set flow rate. If the valve needs to be closed, the previously set value can be quickly restored.

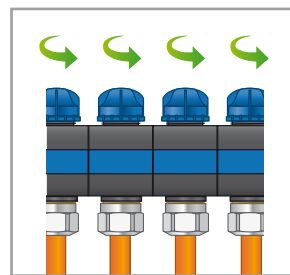

1. Fully open all return valves.

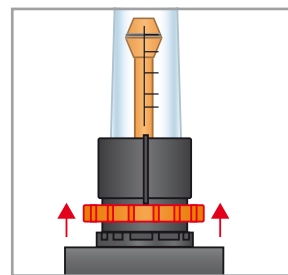

2. Pull up the fixing ring.

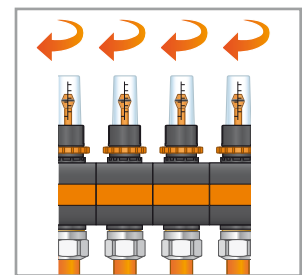

3. Close all flow valves.

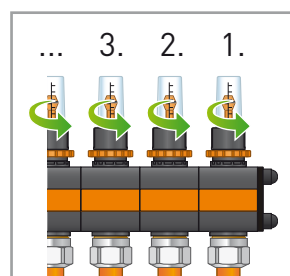

4. Slowly open the flow indicators in sequential order until the display has reached the required flow rate.

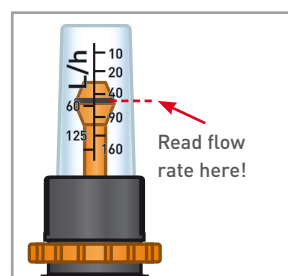

5. Because the flow rates of the individual heating/cooling circuits affect one another, it may be necessary to make corrections to the values in a second run.

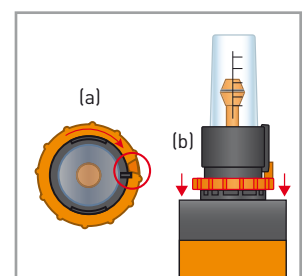

6. (a) Turn the fixing ring clockwise to the stop. (b) Then press the fixing ring down. Consequently, the set value is "saved".



3.12 Clean/replace sight glass

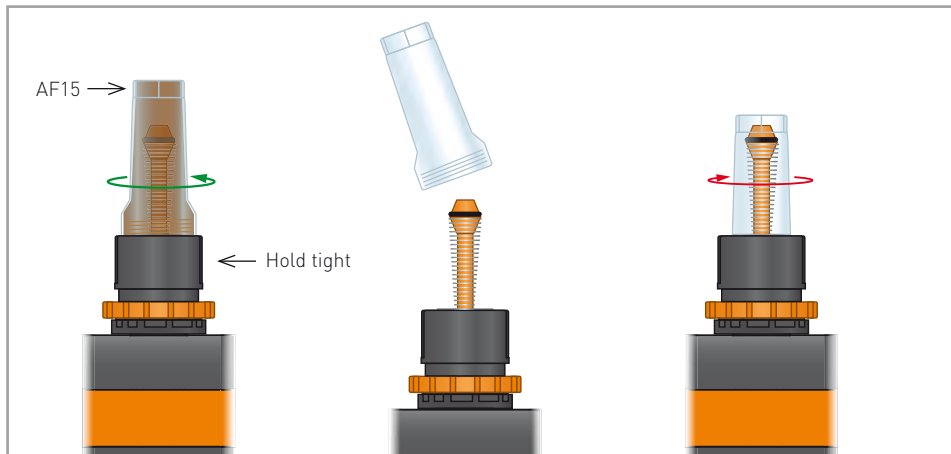

- Hold the black screw cap tight and unscrew the sight glass by hand or with a fork wrench (AF15). Small amount of water from sight glass leaks!
- Clean/replace the sight glass and screw it on again.

- > Sight glass
- > Part No.: VT621
- > PKU: 1 pce.
- > Weight/PKU: 5 g



- > Flow indicator (Flow valve)
- > Part No.: VT620
- > PKU: 1 pce.
- > Weight/PKU: 40 g
- > 10-160 l/h



- > Stop valve (Return valve)
- > Part No.: VT630
- > PKU: 1 pce.
- > Weight/PKU: 20 g

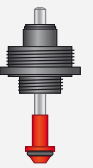

3.13 Replacing the valve with the Duo tool

The VarioManifold must be pressure-less before replacing the valve.

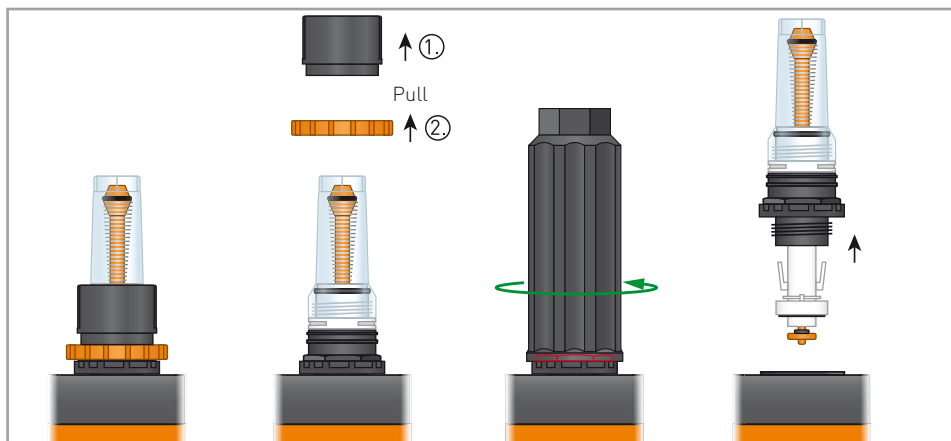

▲ Flow valve replacement

- > Duo tool
- > Part No.: W046
- > PKU: 1 pce.
- > Weight/PKU: 30 g

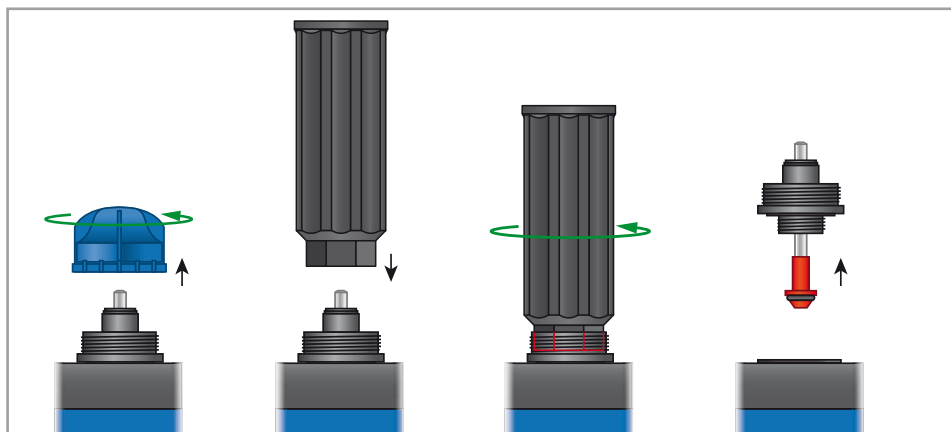

▲ Return valve replacement

4 ACTUATOR

4.1 Actuator

The actuator of the heating/cooling distribution manifold opens or closes the circuit depending on the requirements of the room thermostat.

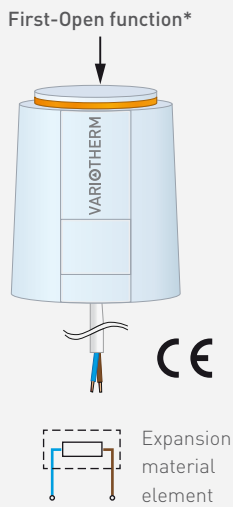

Technical data		
Part No.	VT30	VT31
Type (voltage)	230 V AC 50/60 Hz	24 V AC/DC 0–60 Hz
Activation current	< 550 mA (max. 100 ms)	< 300 mA (max. 2 min.)
Operating current	4.3 mA	42 mA
Operating power	1 W	
Design	Closed when power off (NC)	
Closing and opening times	approx. 3.5 min.	
Adjustment travel	4 mm	
Adjustment force	100 N ± 5 %	
Media temperature	0–100 °C	
Storage temperature	–25 ... +60 °C	
Ambient temperature	0 ... +60 °C	
Protection degree/protection class	IP 54 / II	IP 54 / III
CE conformity as per	EN 60 730	
Housing/housing colour	Polyamide / light blue	
Weight	100 g	
Connection line	2 × 0.75 mm ² PVC grey / 1 m	
Overvoltage resistance as per EN 60 730-1	min. 2.5 kV	

4.2 Actuator with limit switch

This variant of the thermoelectric actuator is also fitted with an internal micro-switch (normally open) with potential-free contact, which closes as soon as voltage is applied to the actuator.

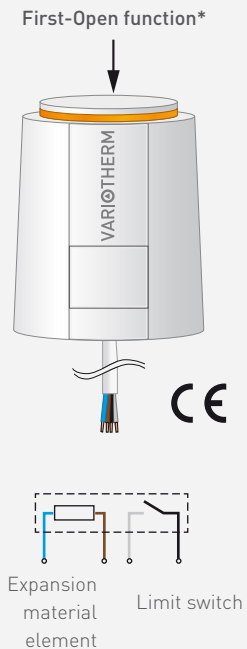

Technical data		
Part No.	VT33	VT35
Type (voltage)	230 V AC 50/60 Hz	24 V AC/DC 0–60 Hz
Activation current	< 550 mA (max. 100 ms)	< 300 mA (max. 2 min.)
Operating current	4.3 mA	42 mA
Operating power	1 W	
Design	Closed when power off (NC)	
Closing and opening times	approx. 3 min.	
Adjustment travel	4 mm	
Adjustment force	100 N ± 5 %	
Limit switch – Switching current	230 V AC: 5 A ohmic load, 1 A inductive load	24 V DC: 3 A ohmic load, 1 A inductive load
Switching point	ca. 2 mm	
Media temperature	0–100 °C	
Storage temperature	–25 ... +60 °C	
Ambient temperature	0 ... +60 °C	
Protection degree/protection class	IP 54 / II	IP 54 / III
CE conformity as per	EN 60 730	
Housing/housing colour	Polyamide / light grey	
Weight	150 g	
Connection line	4 × 0.75 mm ² PVC grey / 1 m	
Overvoltage resistance as per EN 60 730-1	2.5 kV	1 kV

***First-Open function:** The actuator is switched to open when power off by default so that the installer can immediately start the system with installed thermoelectric actuators. If the thermoelectric actuator is energised for more than 6 minutes, it will be switched to closed when power off.

4.3 Installing the actuators

It is not necessary to drain the system!

- 1 Remove the valve's protective cap
- 2 Screw on the grey adapter ring
- 3 Click thermoelectric actuator into place

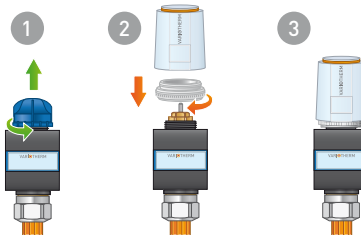

4.4 Functionality description with limit switch

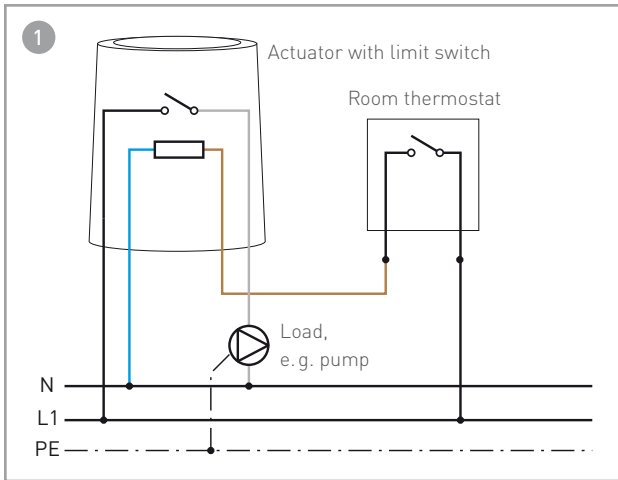

- 1 No heating/cooling requirement:
Room thermostat relay output open → limit switch open, as the actuator is powered off → pump off

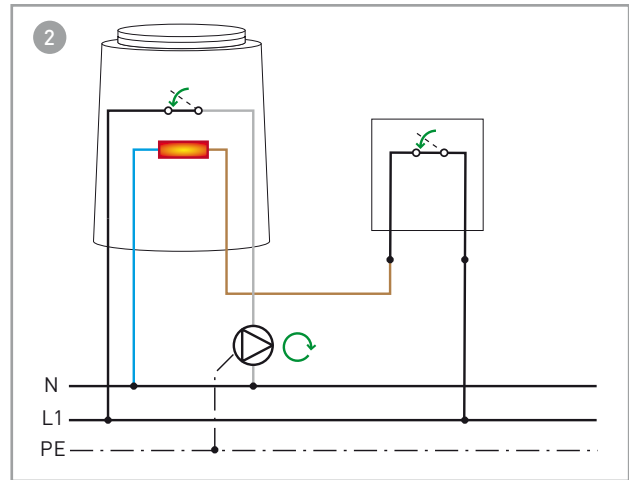

- 2 Heating/cooling requirement present:
Relay output of the room thermostat closed → limit switch closed, as voltage is applied to the actuator → pump running

Wiring examples with several actuators and Pumped VarioManifold

The pump operates if at least one actuator with limit switch is under voltage.

The pump is off if all actuators with limit switches are current-less.

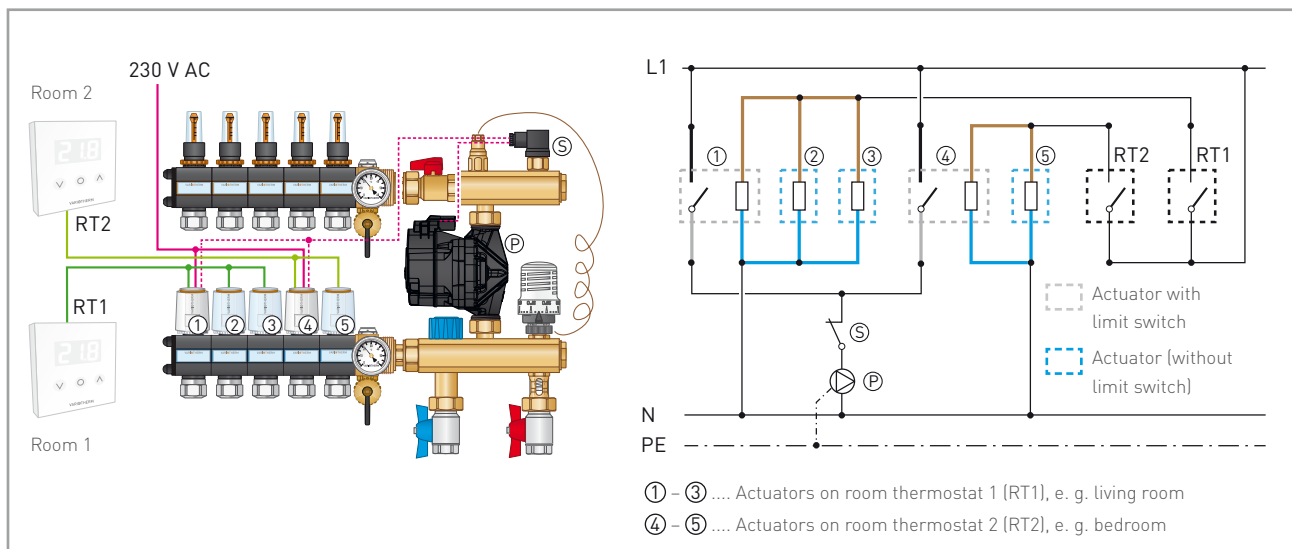

5 CONTROLLERS

5.1 Overview

Central heating systems are to be equipped with state-of-the-art automatic devices for room-specific temperature control. Also see respective operating manual enclosed with the device for installation instructions.

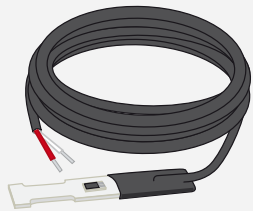

DPS dew point sensor (optional - part no. RT495)

Room thermostat	TOUCH HC(D)
Part No.:	RT49
Operating mode:	Room temperature: Heating, Cooling Dew point monitoring (optional)
Operating voltage:	230 V AC, 50 Hz
Output:	Triac output, non-floating (NO contact), 0.8 A, 230 V AC (max. 8 thermoelectric actuators VT30/VT33 or one piece PVS/PMS pump)
Temperature range:	+5 bis +35 °C
Switching difference:	±0.1 bis ±1.0 K settable
Protection degree:	IP 30
Features:	<ul style="list-style-type: none"> - LED digitally display, dimmable - 3 sensor buttons (touch) - Change-over inlet* for external switching heating/cooling - Internal semiconducting sensor - Push-in connections - Sensor adjustment - Selectable control mode: 2-point or PWM - Dew point monitoring: external dew point sensor DPS required
Status display:	LED red (heating) and LED blue (cooling)
Protection class:	II
Size (H x W x D):	81 x 81 x 16 (36*) mm; * incl. electronics
Attachment:	to in-wall box
Colour:	White

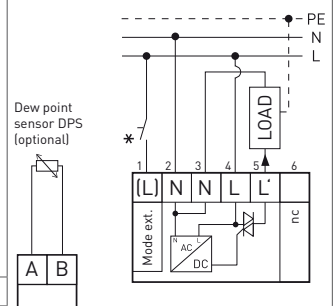

* Optional connection (L)/Mode ext.:

With configuration "temperature setback" (Ab)
 Contact open → set-point temperature
 Contact closed → lowered set-point temperature

With configuration "heating/cooling" (HC)
 Contact open → mode for heating
 Contact closed → mode for cooling
 (= Change-over)

5.2 Dew-point monitoring/sensor DPS

The flow temperature must be selected in such a way or it must be ensured that the surface temperature of the surface cooling (room-side and cavity) and the pipe never reaches or falls below the dew-point temperature at any place. If the flow temperature selected is too low, condensation can form on the pipes and surfaces.

Dew point monitoring is possible with optional DPS dew point sensor (RT495) in combination with the TOUCH HC(D) (RT49) room thermostat!

The dew-point sensor is mounted e. g. with cable ties to the part of the pipe where condensation is expected to form first. This is normally the case on the supply inlet. Care must be taken that there is a good thermal transfer between the pipe and the sensor (use thermal paste!) and that there is a stream of ambient around area of the dew point sensor. For this reason an ambient air connection must be created in the area of the dew-point sensor in the case of closed ceilings. Sensors in flush-mounted junction boxes must not be sealed airtight. The supply must be fixed adequately.

Corrosion protection measures:

According to ÖNORM H 5155, the joints should be protected after the pressure test (e. g. using cold shrink tape or corrosion protection tape). This measure is also a prerequisite for effective dew-point monitoring.



The surface temperature of the surface cooling (room-side and cavity) and the pipe must not reach or fall below the dew-point temperature (see table >>)! The mean surface temperature corresponds approximately to the return temperature.

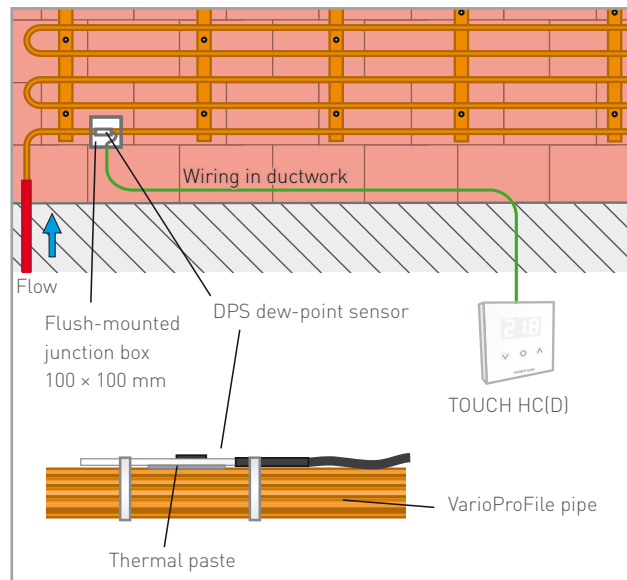

▲ Example EasyFlex wall cooling (plastered)

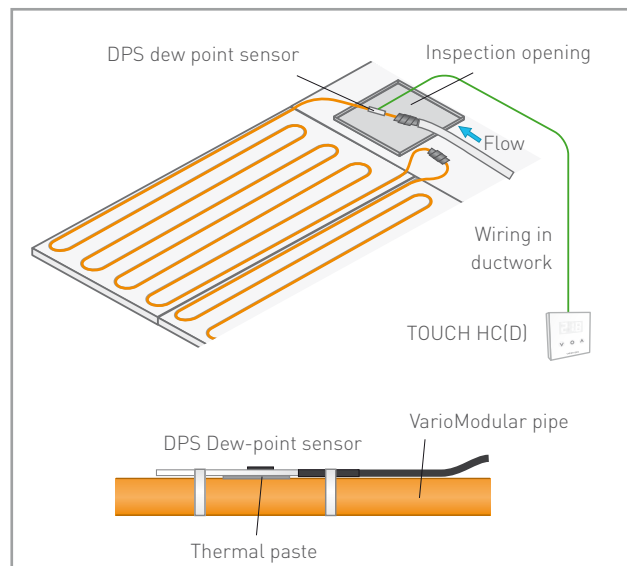

▲ Example Modular ceiling cooling (drywall)

Relative humidity [%RH]	Room temperature T_r [°C]				
	24	25	26	27	28
80 %	20.3	21.3	22.3	23.3	24.2
70 %	18.2	19.1	20.1	21.1	22.0
60 %	15.8	16.7	17.6	18.6	19.5
50 %	12.9	13.9	14.8	15.7	16.6
40 %	9.6	10.5	11.4	12.2	13.1

Dew-point temperature [°C]

6 PUMPED VARIOMANIFOLD

6.1 Description

The Pumped VarioManifold allows the integration of a low-temperature surface heating system (2 to 15 heating circuits) in a high-temperature heating system (2-pipe system) with existing circulation pump. The flow temperature of the primary circuit must be at least 10 K higher

than the set flow temperature of the surface heating circuit.

Observe the required pipe diameter (capacity) to the Pumped VarioManifold. Primary pressure required!

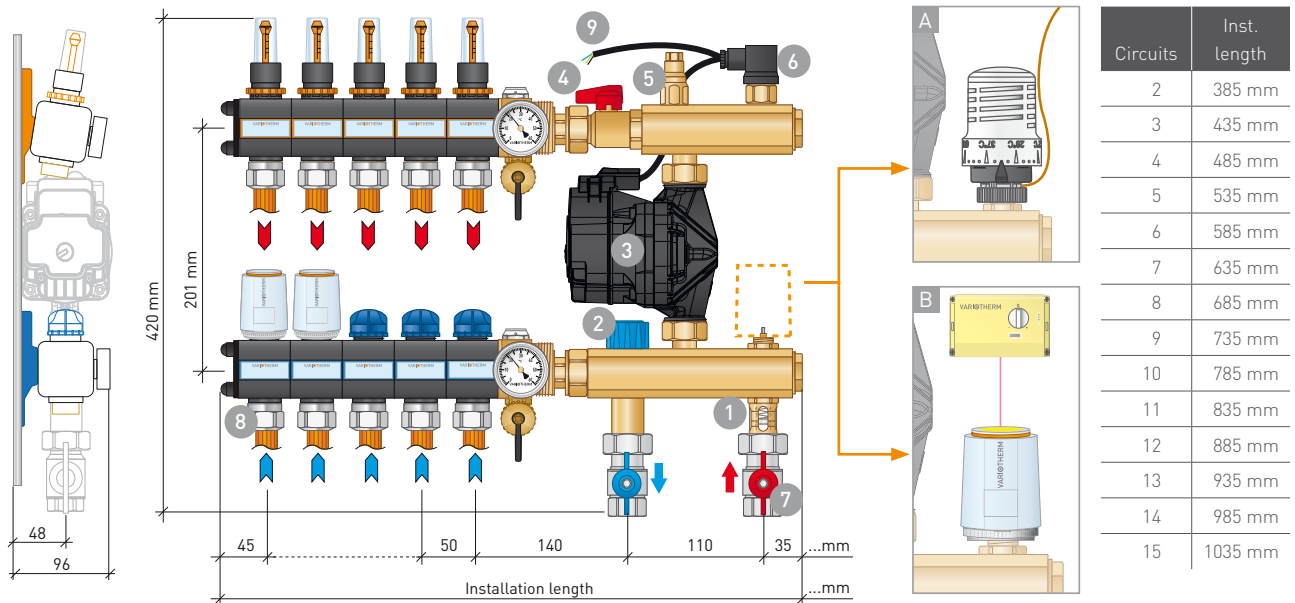

- 1 Flow indicator 2 Regulating valve 3 Pump PVS 4 Flushing ball valve (close when flushing)
- 5 Immersion sleeve for flow temperature sensor; contains heat transfer paste (Safety data sheet: www.variotherm.com)
- 6 Temperature limiter (60 °C) 7 Locking ball valve (3/4" female thread) 8 Variotherm clamping screw fittings 3/4" Eurocone
- 9 230V AC, 50 Hz (provided connection cable: 3 × 0.5 mm² [max. 3 A], please note the electrical protection!)

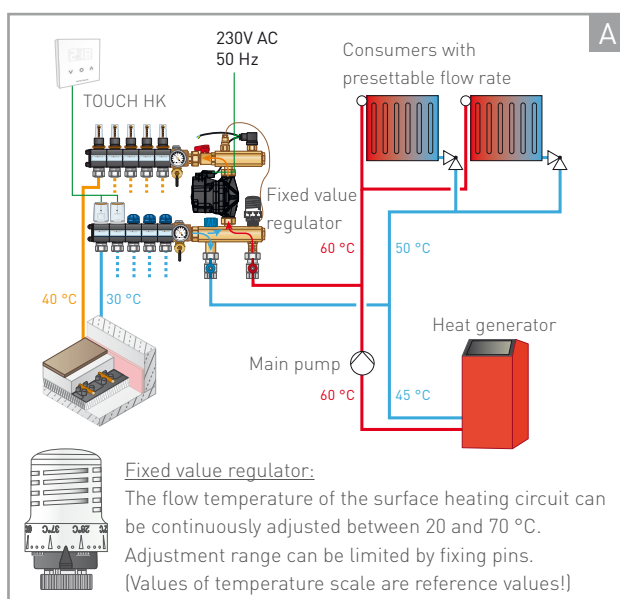

▲ Fixed value control station

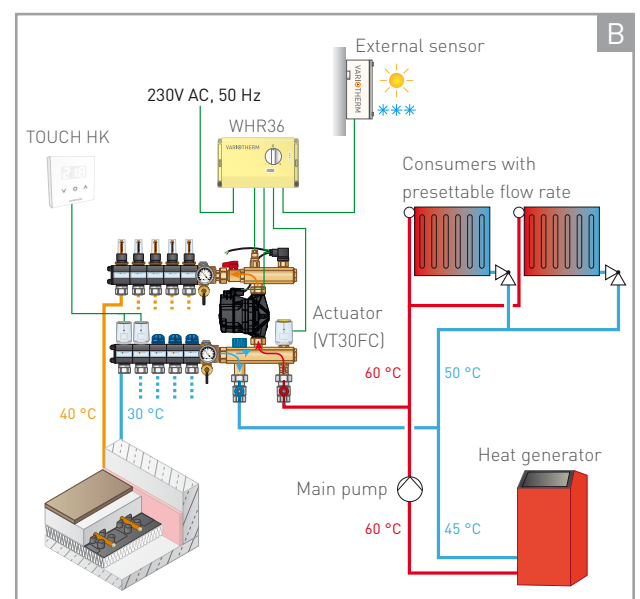

▲ Weather-guided control station

6.2 Examples for power and volume flow

Volume flow in primary circuit	Temp. surface circuit	Flow temp. primary circuit	Power
50 l/h	40/30 °C	50 °C	1163 W
		60 °C	1745 W
		70 °C	2326 W
100 l/h	40/30 °C	50 °C	2326 W
		60 °C	3489 W
		70 °C	5234 W
150 l/h	40/30 °C	50 °C	3489 W
		60 °C	5234 W
		70 °C	6978 W

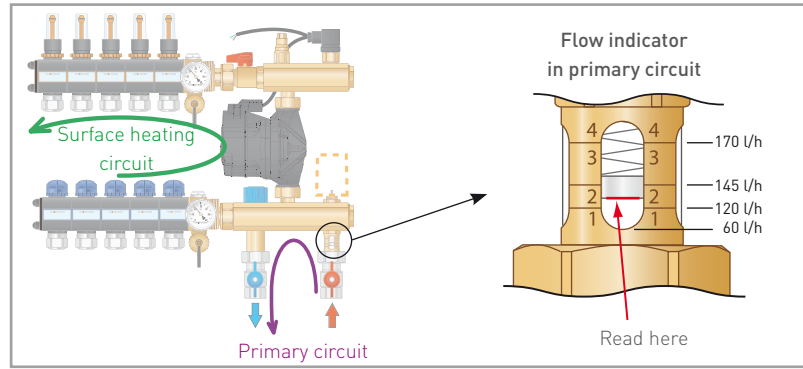

6.3 Pump PVS (TacoFlow3 15–60)

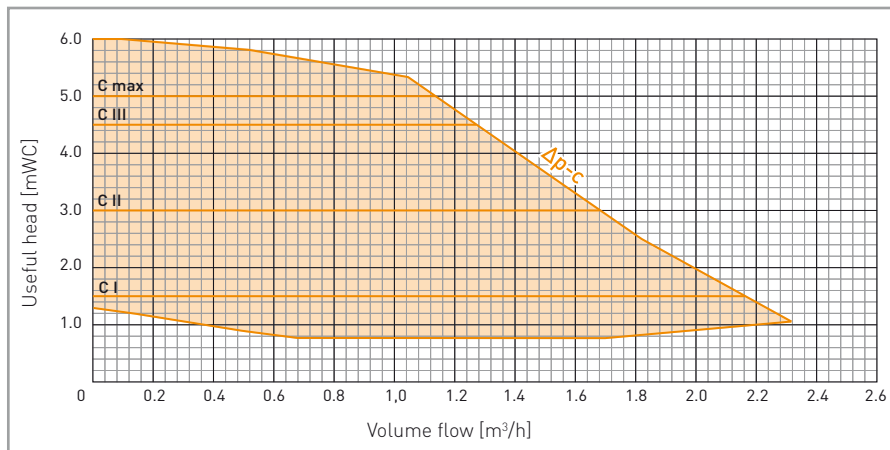

- C, Constant differential pressure for surface heating, (Δp-c)
- min-max, constant rotation speed
- P, Proportional differential pressure
- Malfunction
- Air detected - vent the system

6.4 Regulating valve – Pressure loss in the primary circuit

The flow rate in the primary circuit is adjusted using the regulating valve when the fixed-value regulator or actuator is fully opened (🔴).

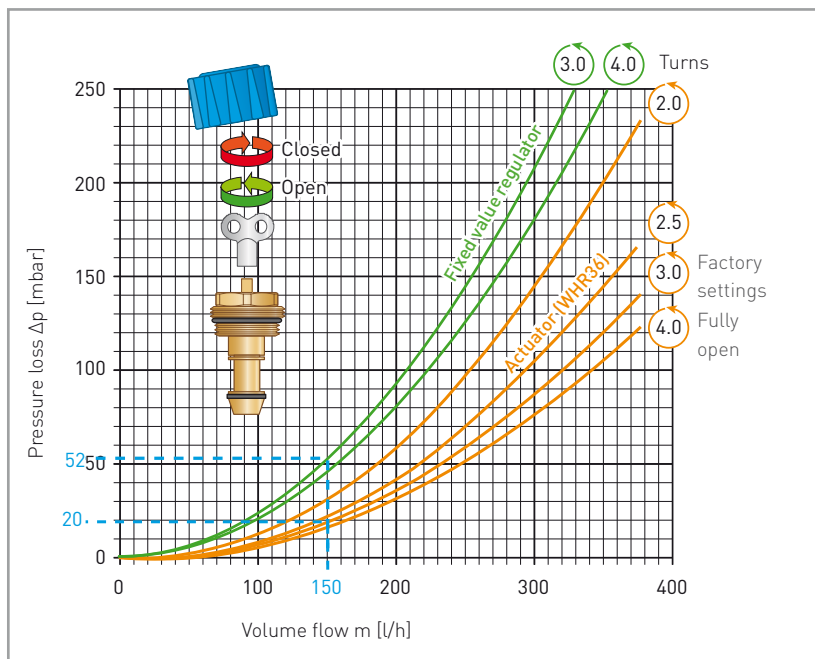

Example 5 heating circuits:

Required for surface heating circuit:
5 × 75 l/h, 40/30 °C.

$$Q = m_1 \times c \times \Delta t_1 = 375 \times 1.163 \times 10 = 4360 \text{ W}$$

Desired for primary circuit:

Pressure loss and volume flow in primary circuit, if regulating valve is 3 turns open.

Primary flow temperature: 55 °C

$$m_2 = Q \div (c \times \Delta t_2) = 4360 \div (1.163 \times 25) = 150 \text{ l/h}$$

Δp with fixed value regulator: 52 mbar (0.52 mWC)

Δp with actuator (WHR36): 20 mbar (0.2 mWC)

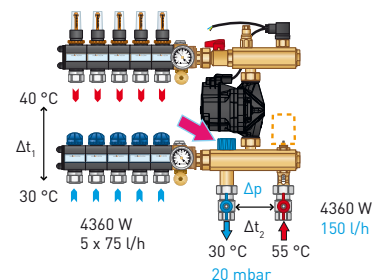

6.5 WHR36 – weather-guided controller

Electrical connection

Terminal block A, 230 V AC	
1	Power supply phase
2	Power supply neutral conductor
3-4	Bridge
5-6	PVS pump incl. safety thermostat relay switching current max. 0.8 A
7-8	Thermoelectric actuator (only item no. VT30FC permissible)
9-0	Boiler demand, with contact 5-6 switched (floating input, max. 0.8 A)

Terminal block B, safety-low voltage	
1-2	Bridge, or optionally: Room thermostat/timer/limit switch with potential-free contact
3-4	External sensor ¹ (cable for example $2 \times 0.75 \text{ mm}^2$, max. 50 m)
5-6	Flow sensor ¹ (cable for example $2 \times 0.75 \text{ mm}^2$, max. 50 m)
7-8	Bridge, or switching contact for pump & actuator On/Off

¹ Use original sensor!

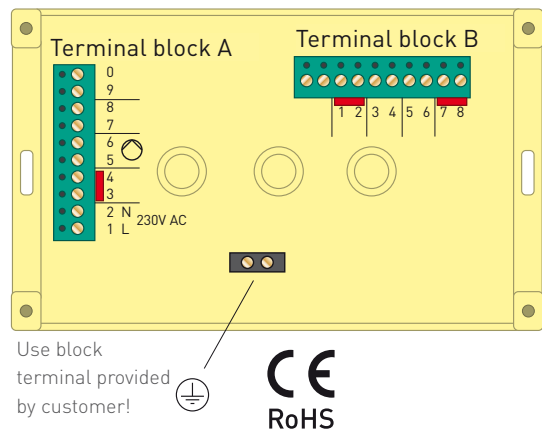

Commissioning

Self-diagnosis is performed when starting for the first time. The red LED flashes for about 5 seconds and goes out. After about 5 minutes the controller begins to adjust the flow temperature to the heating curve. If the red LED is continuously illuminated an alarm is present. In this

case the wiring must be checked. An alarm occurs if the flow temperature in the surface heating circuits exceeds $55 \text{ }^\circ\text{C}$. The controller returns to normal operation when the flow temperature cools to below $52 \text{ }^\circ\text{C}$.

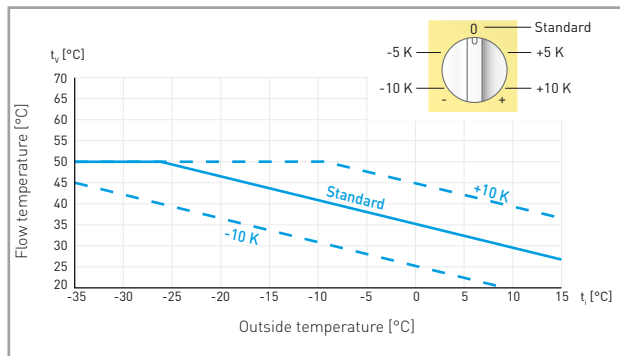

▲ Heating curve

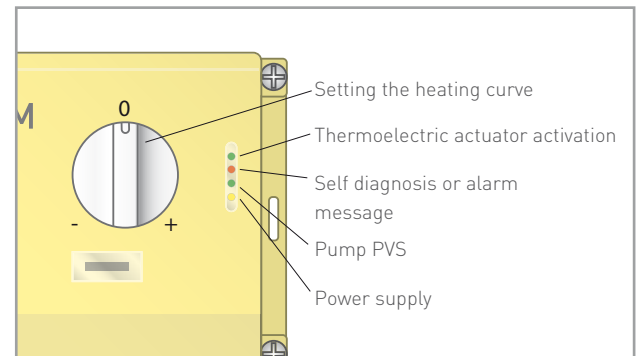

▲ Control panel

Attachment

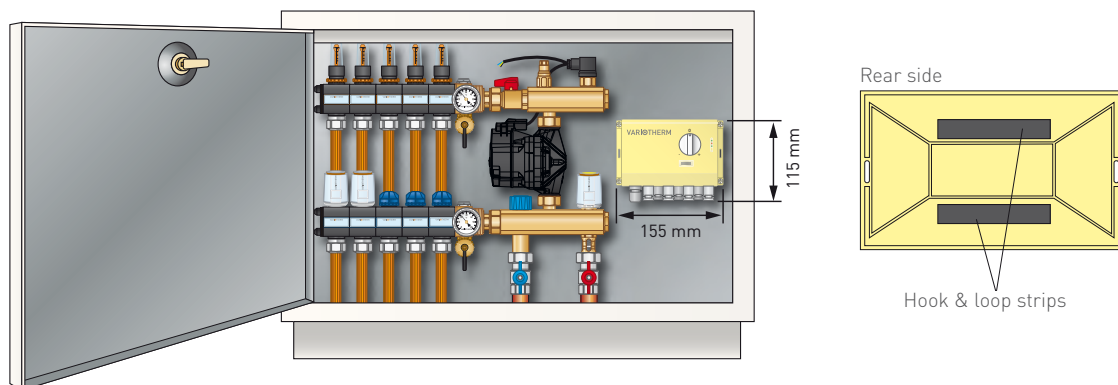

Dry heating

During the heating-up process the outdoor sensor is disconnected (terminal block B, 3-4). The controller works as a fixed value regulator from 25 °C (knob turned fully counter-clockwise to -) to 45 °C (knob turned fully clockwise to +). The temperature is adjusted manually every day.

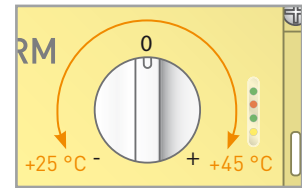

Sensor resistance values

Flow temperature sensor (NTC resistor)					
+15 °C	+20 °C	+25 °C	+30 °C	+35 °C	+40 °C
18.0 kΩ	14.0 kΩ	10.0 kΩ	7.5 kΩ	5.5 kΩ	4.1 kΩ

Outdoor sensor (NTC resistor)					
-20 °C	-10 °C	0 °C	+10 °C	+20 °C	+25 °C
8.23 kΩ	4.90 kΩ	3.00 kΩ	1.90 kΩ	1.25 kΩ	1.00 kΩ

6.6 Mounting positions

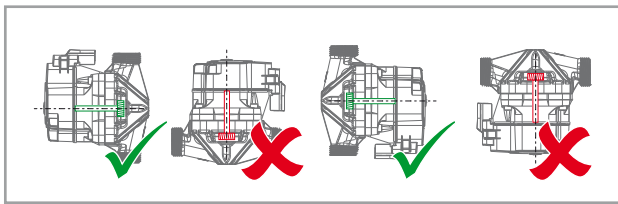

▲ Pump shaft always has to be horizontal (side view)

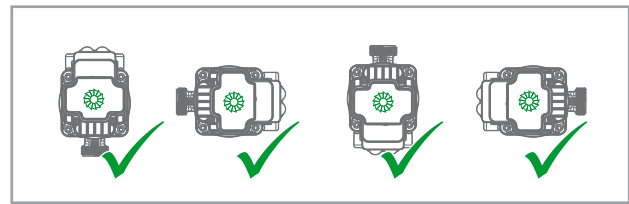

▲ Pump shaft always has to be horizontal (front view)

6.7 Troubleshooting

Fault	Troubleshooting
Surface heating circuit temperature too low	<ul style="list-style-type: none"> • Main pump must be available and running • Fixed value control station: Switch on the pump PVS • Weather-guided control station: <ul style="list-style-type: none"> - Switch on the controller WHR36, orange LED (power on) and green LED (pump on) should glow - Check the heating curve setting • Adjust the surface heating circuit flow • Check and regulate the flow in the primary circuit (regulating valve) • Regulate the existing heating system (e. g. radiators) • Switch main pump to a higher setting level • Check if the flow/return in the primary circuit has been reversed • Air in system, flush again if necessary • Fully open the flushing ball valve • Consider the time for baking out, moisture in surface heating system (wet plaster, screed ...)
Surface heating circuit temperature too high	<p><u>Fixed-value control station:</u></p> <ul style="list-style-type: none"> • Fixed value regulator is not screwed all the way to the end stop <p><u>Weather-guided control station:</u></p> <ul style="list-style-type: none"> • Actuator adapter is not screwed all the way to the end stop • Check the heating curve setting

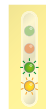

7 PUMP MICROSTATION

7.1 Description

The Pump Microstation allows the integration of a low-temperature surface heating system (1 to 2 heating circuits) in a high-temperature heating system (2-pipe system) with existing circulation pump. The flow temperature of the primary circuit must be at least 10 K higher

than the set flow temperature of the surface heating circuit.

Observe the required pipe diameter (capacity) to the Pump Microstation. Primary pressure required!

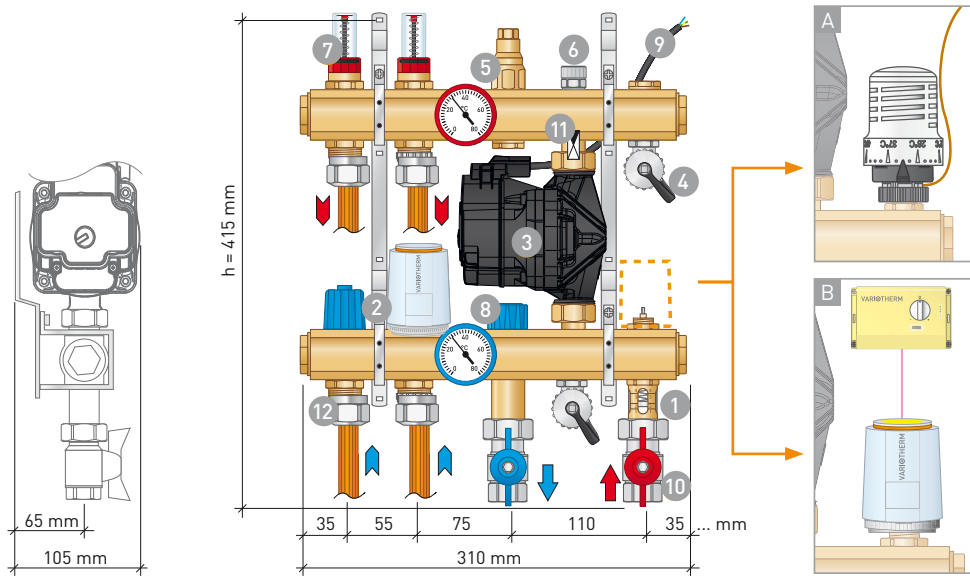

- ① Flow indicator ② Shut-off valve with covering cap (actuator optionally) ③ Pump PMS
- ④ Fill & drain cock ⑤ Immersion sleeve for flow temperature sensor; contains heat transfer paste (Safety data sheet: www.variotherm.com)
- ⑥ Manual air-vent ⑦ Control valve with flow indicator (0–200 l/h) ⑧ Regulating valve
- ⑨ 230V AC, 50 Hz (provided connection cable: 3 x 0.5 mm², max. 3 A, please note the electrical protection!)
- ⑩ Locking ball valve (3/4" female thread) ⑪ Check valve ⑫ Variotherm clamping screw fitting 3/4" Eurocone

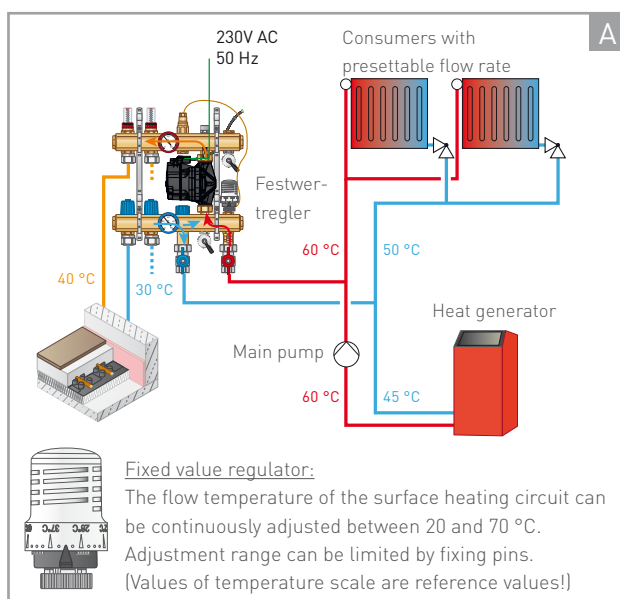

▲ Fixed value control station

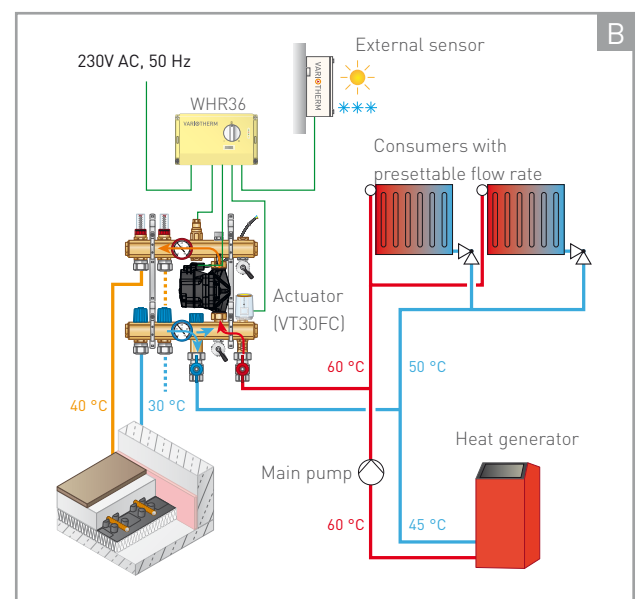

▲ Weather-guided control station

7.2 Examples for power and volume flow

Volume flow in primary circuit	Temp. surface circuit	Flow temp. primary circuit	Power
50 l/h	40/30 °C	50 °C	1163 W
		60 °C	1745 W
		70 °C	2326 W
100 l/h	40/30 °C	50 °C	2326 W
		60 °C	3489 W
		70 °C	5234 W
150 l/h	40/30 °C	50 °C	3489 W
		60 °C	5234 W
		70 °C	6978 W

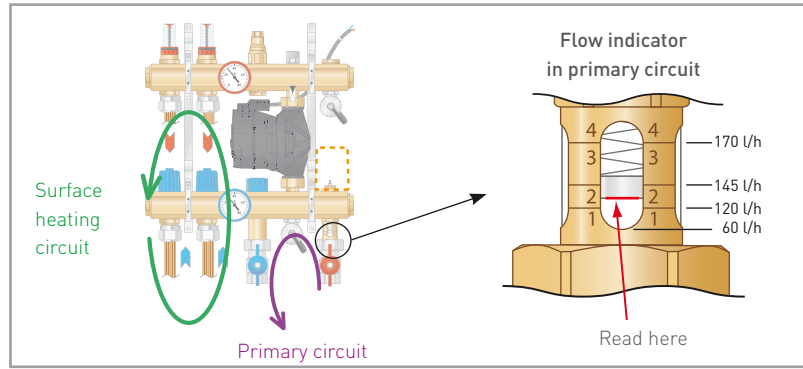

7.3 Pump PMS (TacoFlow3 15–60)

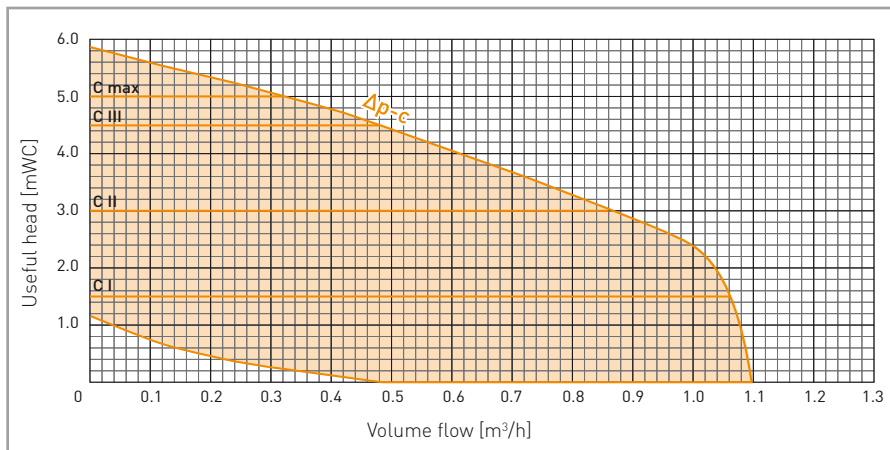

- C, Constant differential pressure, for surface heating, ($\Delta p-c$)
- min-max, constant rotation speed
- P, Proportional differential pressure
- Malfunction
- Air detected - vent the system

7.4 Regulating valve – Pressure loss in the primary circuit

The flow rate in the primary circuit is adjusted using the regulating valve when the fixed-value regulator or actuator is fully opened (🔑).

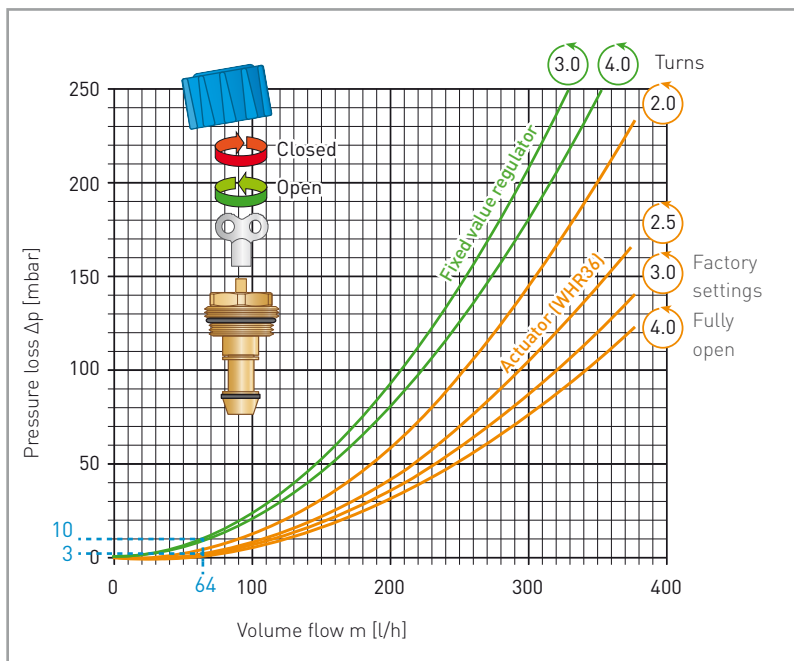

Example 2 heating circuits:

Required for surface heating circuit:
 $2 \times 80 \text{ l/h}$, $40/30 \text{ °C}$.

$$Q = m_1 \times c \times \Delta t_1 = 160 \times 1.163 \times 10 = 1860 \text{ W}$$

Desired for primary circuit:

Pressure loss and volume flow in primary circuit, if regulating valve is 3 turns open.

Primary flow temperature: 55 °C

$$m_2 = Q \div (c \times \Delta t_2) = 1860 \div (1.163 \times 25) = 64 \text{ l/h}$$

Δp with fixed value regulator: 10 mbar (0.1 mWC)

Δp with actuator (WHR36): 3 mbar (0.03 mWC)

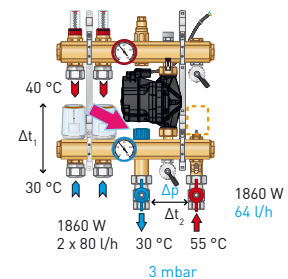

7.5 WHR36 – weather-guided controller

Electrical connection

Terminal block A, 230 V AC

1	Power supply phase
2	Power supply neutral conductor
3-4	Bridge
5-6	PMS pump incl. safety thermostat relay switching current max. 0.8 A
7-8	Thermoelectric actuator (only item no. VT30FC permissible)
9-0	Boiler demand, with contact 5-6 switched (floating input, max. 0.8 A)

Terminal block B, safety-low voltage

1-2	Bridge, or optionally: Room thermostat/timer/limit switch with potential-free contact
3-4	External sensor ¹ (cable for example 2 × 0.75 mm ² , max. 50 m)
5-6	Flow sensor ¹ (cable for example 2 × 0.75 mm ² , max. 50 m)
7-8	Bridge, or switching contact for pump & actuator On/Off

¹ Use original sensor!

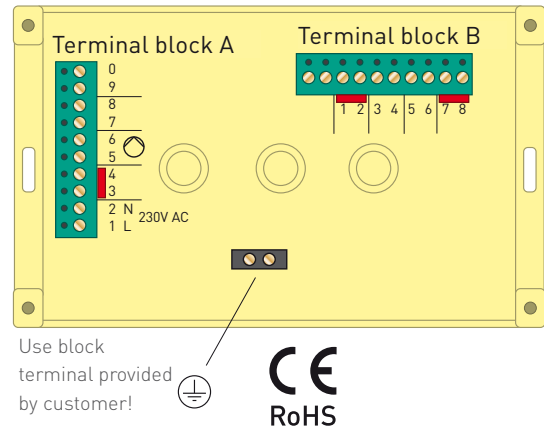

Commissioning

Self-diagnosis is performed when starting for the first time. The red LED flashes for about 5 seconds and goes out. After about 5 minutes the controller begins to adjust the flow temperature to the heating curve. If the red LED is continuously illuminated an alarm is present. In this

case the wiring must be checked. An alarm occurs if the flow temperature in the surface heating circuits exceeds 55 °C. The controller returns to normal operation when the flow temperature cools to below 52 °C.

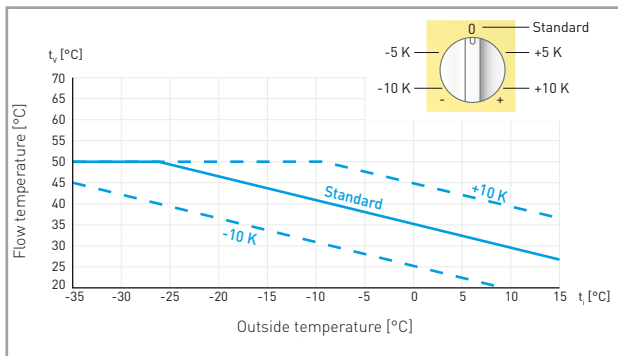

▲ Heating curve

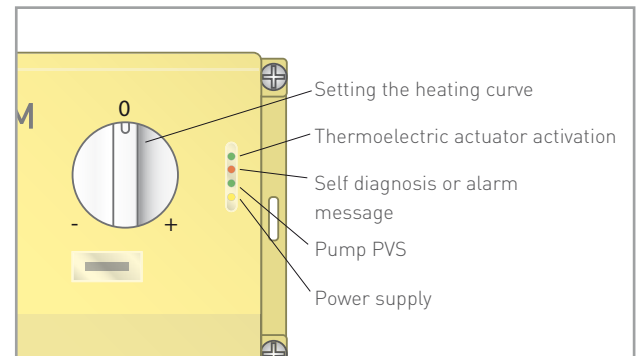

▲ Control panel

Attachment

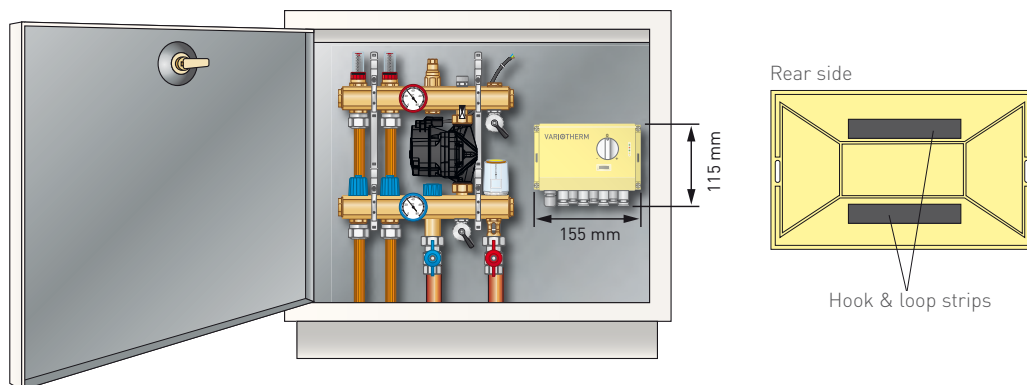

Dry heating

During the heating-up process the outdoor sensor is disconnected (terminal block B, 3-4). The controller works as a fixed value regulator from 25 °C (knob turned fully counter-clockwise to -) to 45 °C (knob turned fully clockwise to +). The temperature is adjusted manually every day.

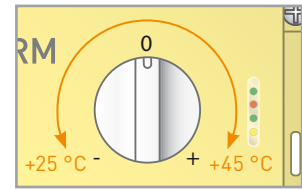

Sensor resistance values

Flow temperature sensor (NTC resistor)					
+15 °C	+20 °C	+25 °C	+30 °C	+35 °C	+40 °C
18.0 kΩ	14.0 kΩ	10.0 kΩ	7.5 kΩ	5.5 kΩ	4.1 kΩ

Outdoor sensor (NTC resistor)					
-20 °C	-10 °C	0 °C	+10 °C	+20 °C	+25 °C
8.23 kΩ	4.90 kΩ	3.00 kΩ	1.90 kΩ	1.25 kΩ	1.00 kΩ

7.6 Mounting positions

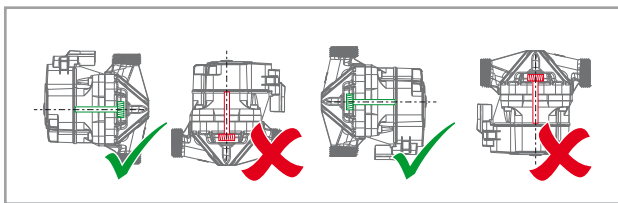

▲ Pump shaft always has to be horizontal (side view)

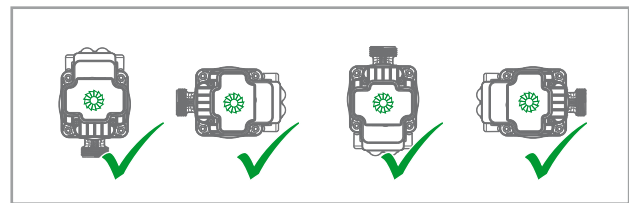

▲ Pump shaft always has to be horizontal (front view)

7.7 Troubleshooting

Fault	Troubleshooting
Surface heating circuit temperature too low	<ul style="list-style-type: none"> • Main pump must be available and running • Fixed value control station: Switch on the pump PMS • Weather-guided control station: <ul style="list-style-type: none"> - Switch on the controller WHR36, orange LED (power on) and green LED (pump on) should glow - Check the heating curve setting • Adjust the surface heating circuit flow • Check and regulate the flow in the boiler circuit (regulating valve) • Regulate the existing heating system (e. g. radiators) • Switch main pump to a higher setting level • Check if the flow/return in the boiler circuit has been reversed • Air in system, flush again if necessary • Consider the time for baking out, moisture in surface heating system (wet plaster, screed ...)
Surface heating circuit temperature too high	<p><u>Fixed-value control station:</u></p> <ul style="list-style-type: none"> • Fixed value regulator is not screwed all the way to the end stop <p><u>Weather-guided control station:</u></p> <ul style="list-style-type: none"> • Actuator adapter is not screwed all the way to the end stop • Check the heating curve setting



8 RETURN TEMPERATURE LIMITER

The return temperature limiter allows the integration of a low-temperature surface heating system in a high-temperature heating system (2-pipe system) with existing circulation pump. Maximum pipe length of the surface heating circuit: approx. 90 m with \varnothing 16 mm pipe. approx. 60 m with \varnothing 11.6 mm pipe. Maximum flow temperature of the primary circuit: 60 °C



- > RTL valve without thermostatic valve
- > Part No.: RT46
- > PKU: 1 pce.
- > Weight/PKU: 3.0 kg
- > Mounting box, dimensions (W x H x D): 300 x 200 x 60 mm
- > White plastic cover panel (W x H): 340 x 235 mm

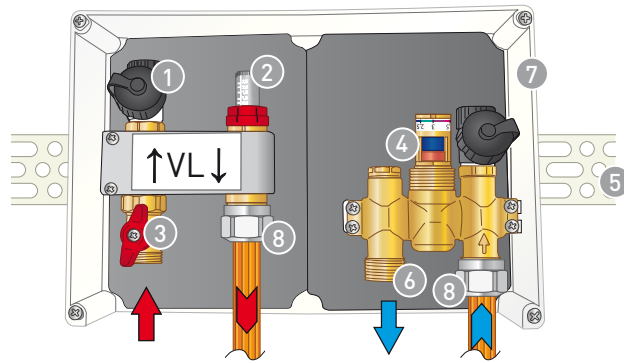
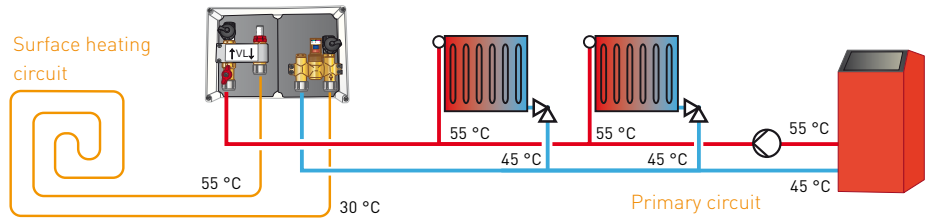

- 1 Fill & drain cock 3/4"
- 2 Flow indicator 0.5–2.5 l/min adjustable with locking device
- 3 Locking ball valve
- 4 Return temperature limiter with expanding element sensor (20–40 °C, adjustable, swivel-mounted)
- 5 Fastening clip
- 6 3/4" Eurocone connections (4x)
- 7 Mounting box, dimensions (W x H x D): 300 x 200 x 60 mm
- 8 Variotherm clamping screw fittings 3/4" Eurocone (not included!)



- > RTL valve with thermostatic valve
- > Part No.: RT45
- > PKU: 1 pce.
- > Weight/PKU: 3.2 kg
- > Mounting box, dimensions (W x H x D): 300 x 200 x 60 mm
- > White plastic cover panel (W x H): 340 x 235 mm

Setting the return temperature

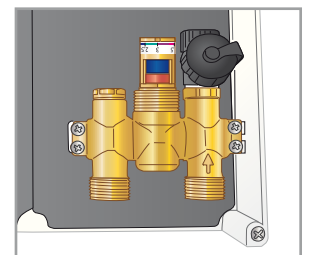
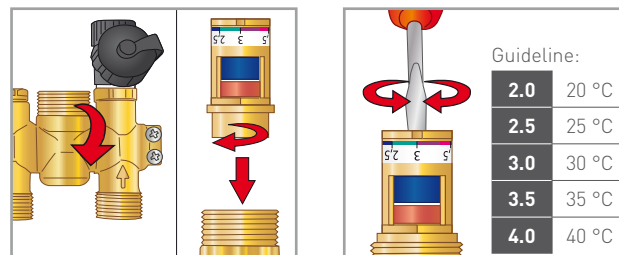

Installing the thermostatic head (RT45)

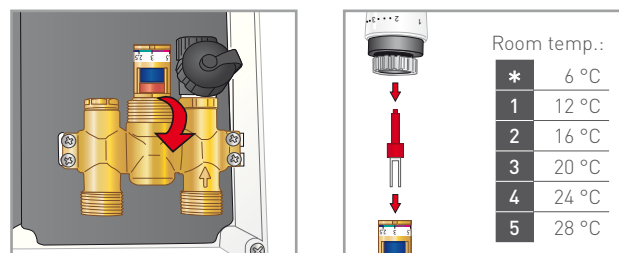



ENJOY THE COMFORT & SAVE ENERGY

That's why our customers love us:
Heating and cooling optimised for COMFORT in all rooms!
Fast and friendly service, ANSWERS backed up with expertise!
Always in tune with the latest technology, INNOVATION guaranteed!
Everything CLEAR and SIMPLE, in writing of course!
PROFESSIONALISM at all times, from the first contact to the reference list!

VARIO THERM SINCE 1979

Variotherm is an Austrian model plant with hundreds of partners in Austria, Europe and around the world.



VBOOK9_EN | 8/2025
(rev. 1)

Variotherm Partner:

VARIO THERM HEIZSYSTEME GMBH

GÜNSELSDORFER STRASSE 3A
2544 LEOBERSDORF
AUSTRIA

Phone: +43 [0] 22 56 - 648 70-0

office@variotherm.com www.variotherm.com

All rights pertaining to distribution and translation, in whole or in part, including film, radio, television, video recording, Internet, photocopying and reprinting, are reserved. Subject to mistakes and printing errors. Misprints and errors excepted.