

# TH INSTALLATION

TRENCH HEATING. INDIVIDUAL.

BKH1 mini

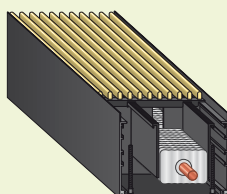
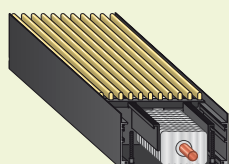

BKH1

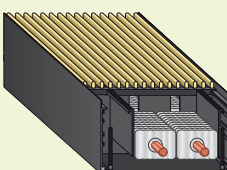
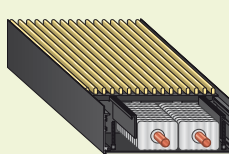
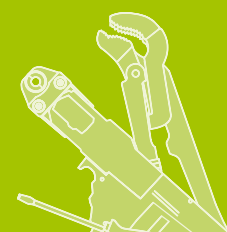

BKH2

BKH2 mini



PDF



1. Safety information .....	3
1.1 General ⚠.....	3
1.2 Guarantee conditions ⚠ .....	3
1.3 Storage of pre-insulated Variomodular pipe 16x2 ⚠ .....	3
1.4 Tray and grid ⚠ .....	3
1.5 Heating element ⚠ .....	3
1.6 Maximum Operating Pressure ⚠ .....	3
2. Preparation .....	4
2.1 Overview of trench heating types .....	4
2.2 Maximum length of heating element per heating circuit .....	4
2.3 Tools .....	5
2.4 Side strip .....	5
2.5 Connecting the heating elements with the BKH2 and BKH2 mini .....	5
3. Installation .....	6
3.1 Grid.....	6
3.2 Assembling a trench with mitres or extra length .....	6
3.3 Window side .....	6
3.4 Arrangement and alignment.....	6
3.5 Fixing bracket .....	7
3.6 Installation examples .....	7
4. Connection .....	8
4.1 Hydraulic connection on manifold system .....	8
4.2 Hydraulic connection on 2-pipe system .....	9
4.3 Connection examples .....	12
5. Protocols .....	15
5.1 Leak-tightness test.....	15
5.2 Commissioning.....	15

## 1.1 General ⚠

These installation instructions are intended for authorised specialist personnel.  
Observe the applicable local regulations and standards for electrical and heating installations.

## 1.2 Guarantee conditions ⚠

If the heating system is installed or commissioned incorrectly, all claims on the basis of the manufacturer's warranty and guarantee become void. Our currently applicable installation instructions are an integral part of our guarantee!

## 1.3 Storage of pre-insulated Variomodular pipe 16x2 ⚠

The pre-insulated Variomodular pipe is an aluminium multi-layer composite pipe (100 % oxygen diffusion-tight). Damage (e.g. denting and scratching) is to be avoided during storage, transport, unloading, unwinding and laying. This type of damage has a detrimental effect on the creep behaviour.

In order to prevent damage to the Variomodular pipe during the construction phase, high-visibility warning signs should be placed at appropriate locations.

The interaction of the air's oxygen with UV rays damages the pipes, which should not be stored in the open air. Normal temporary storage on the construction site for a few days is permissible.

At low temperatures ( $\leq 5\text{ °C}$ ) the Variomodular pipe should be stored in heated rooms prior to processing.

## 1.4 Tray and grid ⚠

Take care to avoid damage during storage, transport and installation.

The grid and the tray must be protected against contamination. Open the packaging by hand and not with sharp utensils. The grid should not be unpacked and inserted into the ducted channel until all installation and floor-laying work has been completed.

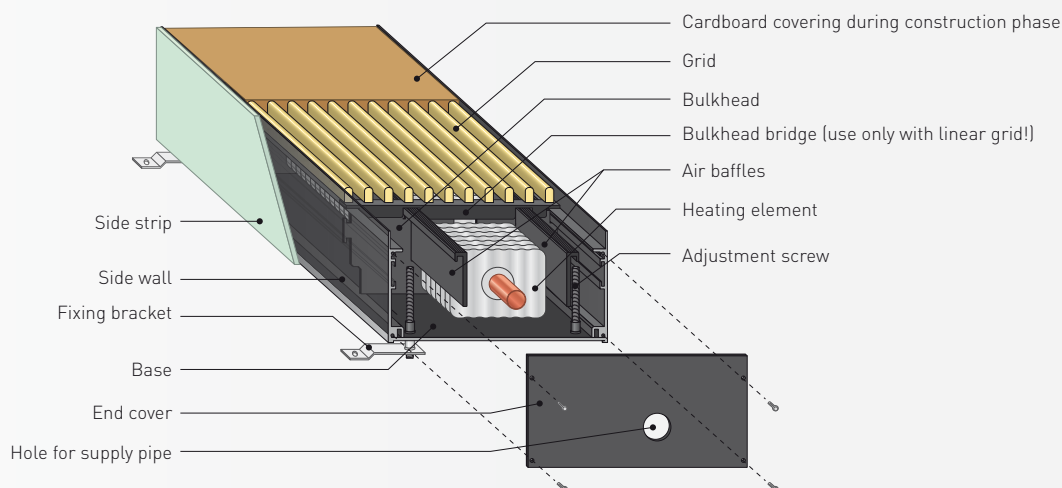

## 1.5 Heating element ⚠

The heating elements are supplied pre-installed in the trench. They must be protected against damage or unintentional bending of the louvres. During the construction phase, i.e. until commissioning, the cardboard covering (14 mm thick) is inserted into the tray instead of the grid.

The heating element consists of a copper pipe  $\varnothing 18 \times 0.5\text{ mm}$  (DIN EN 12449) with aluminium louvres  $56 \times 78\text{ mm}$ .

## 1.6 Maximum Operating Pressure ⚠

With Variotherm distribution manifold systems: max. 6 bar

With 2-pipe-system: max. 6 bar when using a Flexible Pipe Bend, otherwise 10 bar

## 2.1 Overview of trench heating types

Trench:	Aluminium side walls and end cover (black anodised), black-grey aluminium base, air baffles, heating element mounting bulkheads, interior adjustment screws for height adjustment, site strips green, fixing brackets
Length:	Custom length (with lengths > 5000 mm, the trench is supplied in segments)
Grid types:	Linear or roll grid, anodised aluminium, safe to walk on, standard colours: Natural aluminium (EV 1), Light bronze (C 32), Black (C 35)
Heating element:	Copper pipe $\varnothing 18 \times 0.5$ mm (DIN EN 12449) with aluminium louvres $56 \times 78$ mm

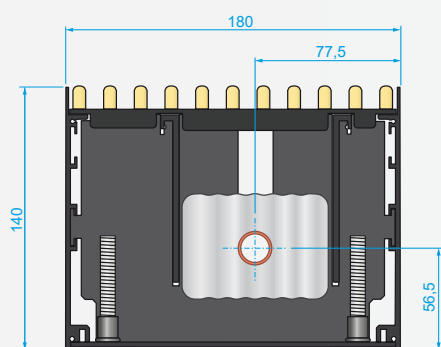

BKH1

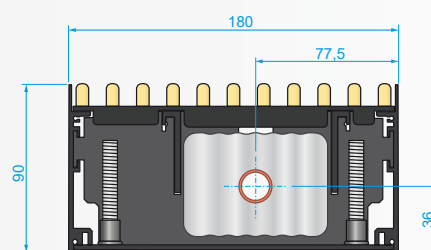

BKH1 mini

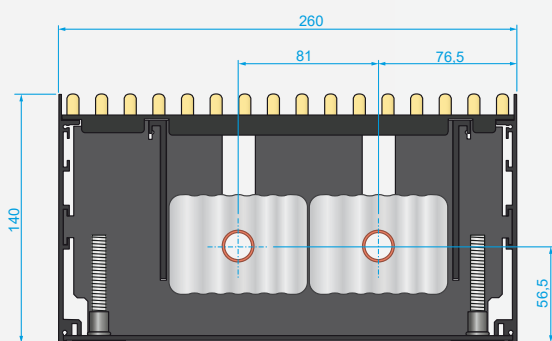

BKH2

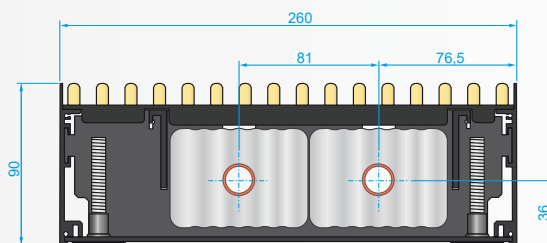

BKH2 mini

## 2.2 Maximum length of heating element per heating circuit

**BKH1/BKH1 mini:** max. 7.5 m (= 7.5 m heating element)

**BKH2/BKH2 mini:** max. 5.0 m (= 10 m heating element)

## 2.3 Tools

Variotherm tools

Pipe cutting pliers

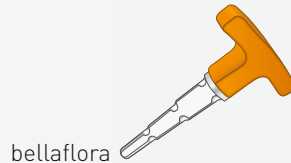

bellafloira

Calibration and chamfering tool

Additional tools that are required/recommended for installation work:



Pipe cutter for copper/stainless steel pipes

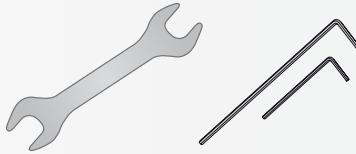

Open-end wrench (size 21) &amp; Allen key (size 3 and 4)



Drill / battery-powered screwdriver

## 2.4 Side strip

The side strips are pre-mounted on the end caps and enclosed in the side walls. These will be attached before installing the ducted channel.

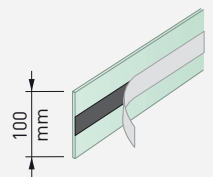

## 2.5 Connecting the heating elements with the BKH2 and BKH2 mini

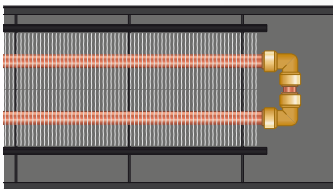

Connection set (Z113), consisting of:  
2 pcs. push-in fitting elbow 90° 18 (i/i) and  
1 pce. 60mm copper pipe 18 x 0.5mm

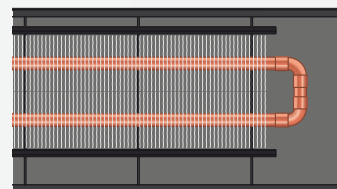

Optionally with solder fittings (on-site)

### 3.1 Grid

The grid should not be inserted into the trench until all installation and floor-laying work has been completed.

### 3.2 Assembling a trench with mitres or extra length

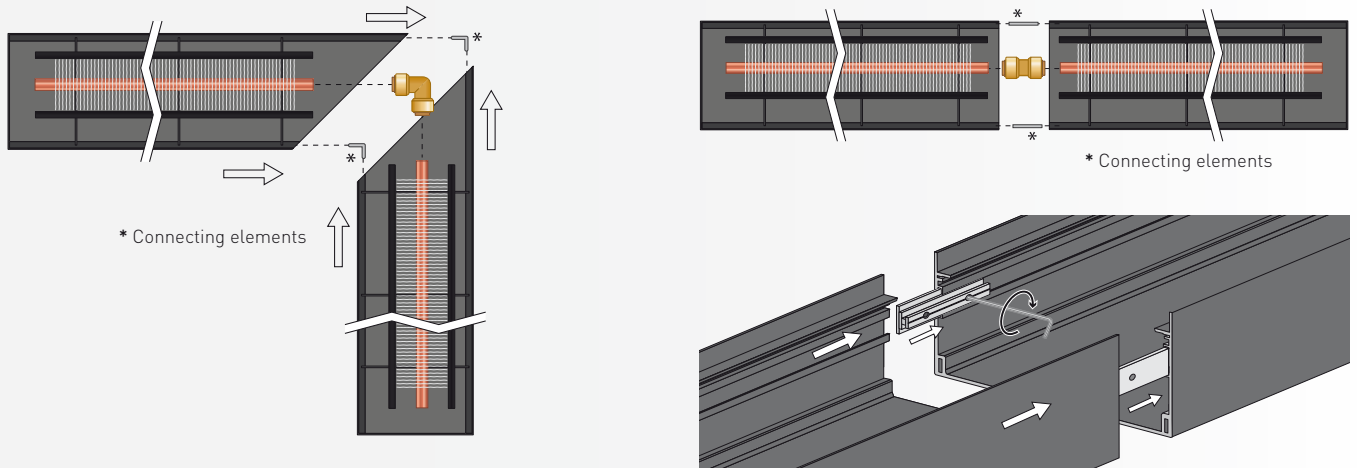

After plugging the parts together using the connectors and push-in fittings, they are then screwed tight with the inserted grub screws. Allen key required: size 3.

The heating elements are soldered or pressed together (see table below).

The length of the air baffles must be adjusted in line with the connection piping.

Pipe material	Support bracket	Viega		Sanha	
		Press fitting	Press-fitting jaws	Press fitting	Press-fitting jaws
Copper	Yes	Profipress Sanpress	V18	Pressfitting series 6000/8000	SA18

### 3.3 Window side

Pay attention to the specified window side when positioning the ducted channel. This is also labelled on the side wall of the ducted channel.

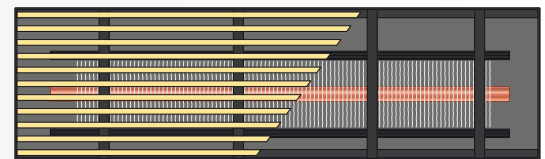

Window side

### 3.4 Arrangement and alignment

Lay the Variotherm trench heating system in the correct arrangement with respect to the window. The maximum distance to the glass surface is 200 mm (allow for the flooring to be installed). The adjustment screws are used to align the trench level with the height of the finished floor (FFL). Allen key required: size 4 × 137 mm

**Note on free accessibility:** Due to the distances between the interior adjustment screws of  $\leq 500$  mm, the trench can be accessed without further measures being required! (Load up to 130 kg/m at a adjustment screw distance of  $\leq 500$  mm).

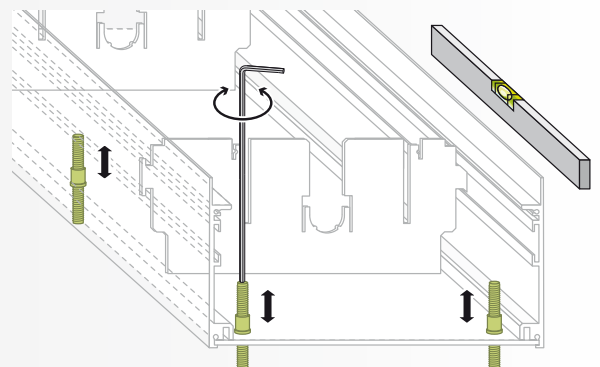

## 3.5 Fixing bracket

Fix the trench with the fixing brackets on the ground.

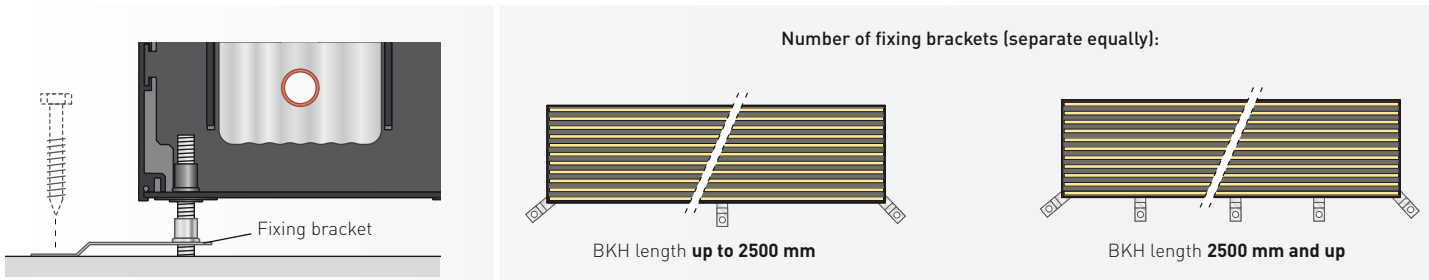

## 3.6 Installation examples

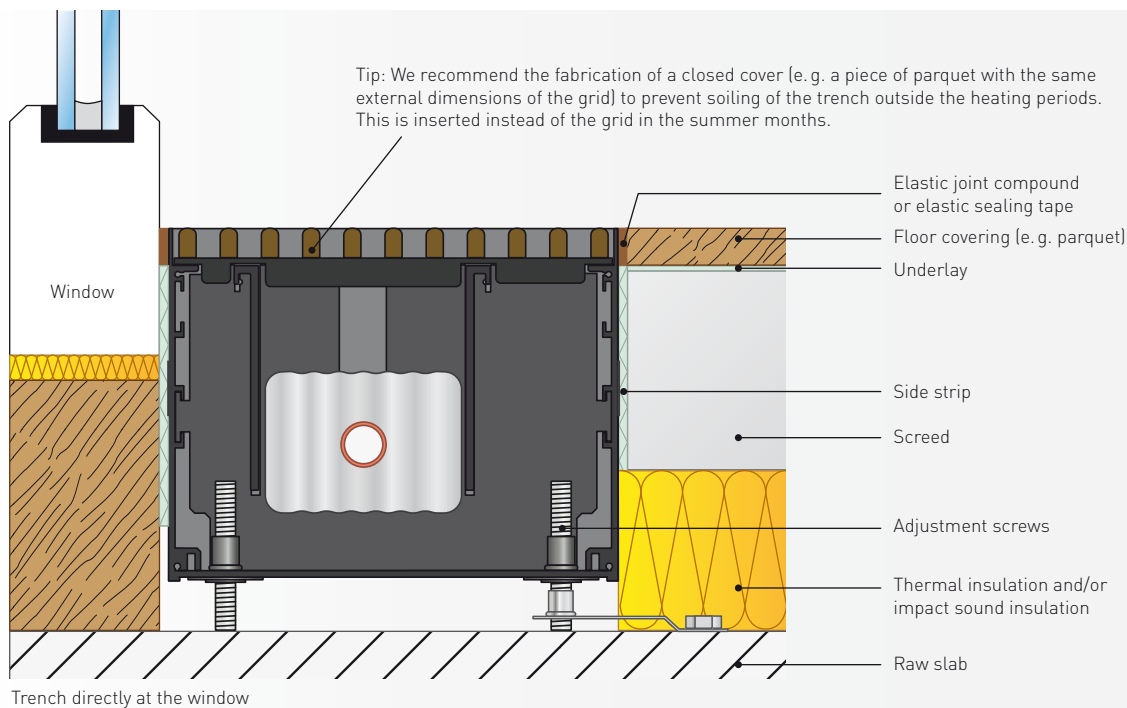
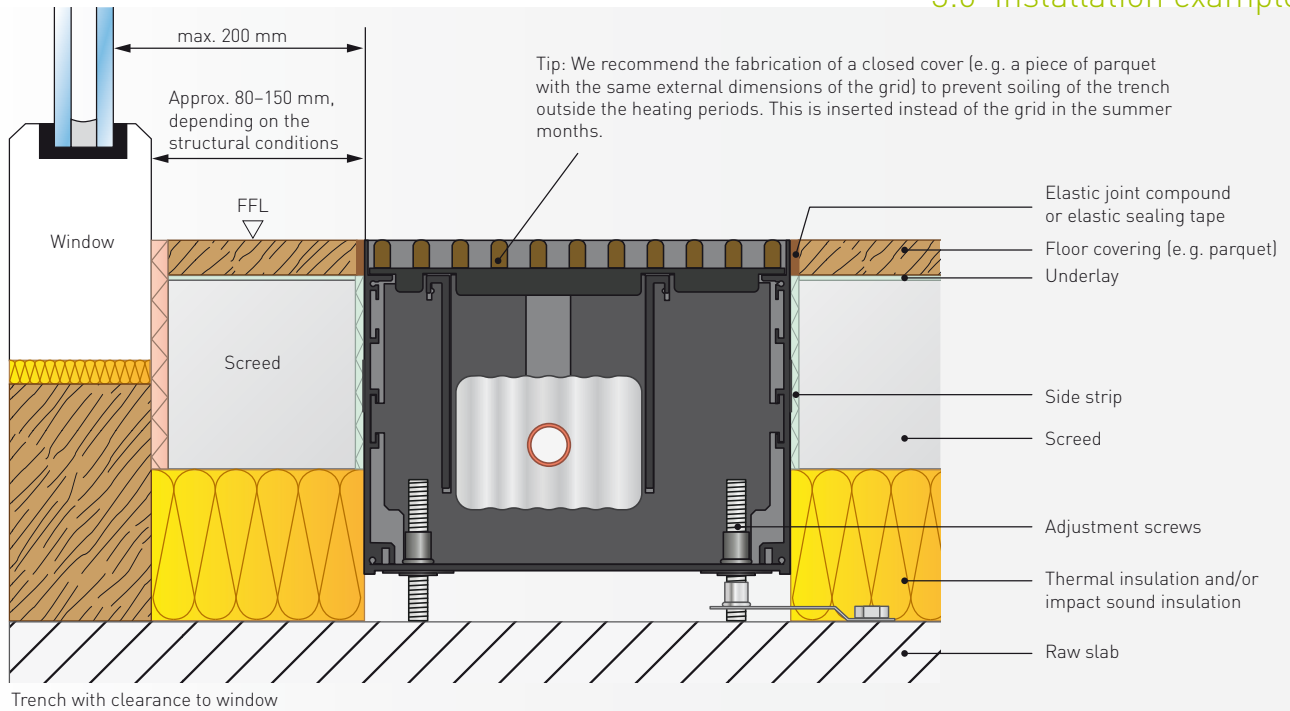

## 4.1 Hydraulic connection on manifold system

For installations with manifold systems, first lay the **pre-insulated Variomodular pipes 16x2** from the manifold to the trench heating and back, and then connect them to the manifold via a screw fitting. There must not be any kinks in Variomodular pipes when laying them and should be routed endlessly (i.e. without additional connection points) from the manifold to the skirting heating.

Electronic room thermostats and actuators are used to control the room temperature.

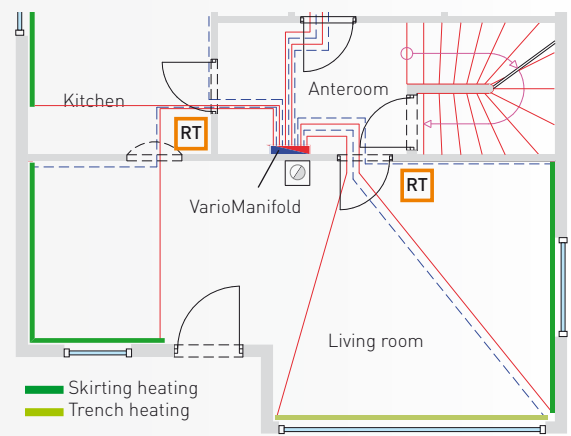
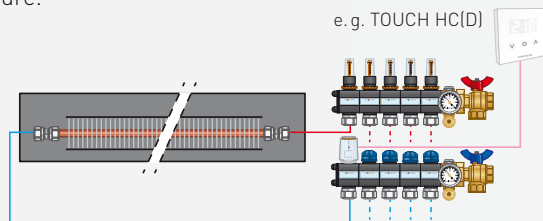

Laying example with Variotherm distribution manifold

### 4.1.1 Cutting to length, calibrating and bevelling the pre-insulated Variomodular pipe

The Variotherm pipe cutting pliers is used to cut the pipe to length.

**Caution:** The pipe must be cut at a right angle.

Rotate the calibration tool into the pipe to the stop angle to calibrate and bevel the end of the pipe. Visually check that the face of the pipe is smooth, clean and free of chips.

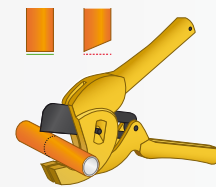

Pipe cutting pliers



Calibration and bevelling tool

### 4.1.2 Feed to flow and return

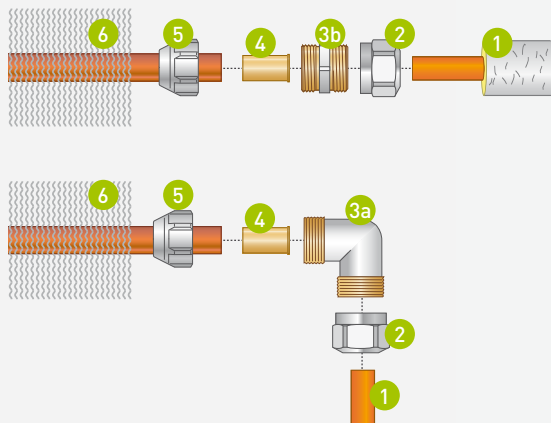

- 1 Pre-insulated Variomodular pipe 16x2
- 2 3/4" EUROx16 clamping screw fitting
- 3a 90° angle piece 3/4" EURO or 3b Double nipple 3/4" EURO
- 4 18 x 17 mm support sleeve (only necessary with heating element with copper pipe!)
- 5 3/4" EUROxCu18 clamping screw fitting
- 6 Heating element (copper pipe  $\varnothing 18 \times 0.5$  mm)

#### Connecting the supply pipe:

Push the clamping screw fitting **2** over the pre-insulated Variomodular pipe. **1** Then screw the clamping screw fitting with the angle piece **3a** or double nipple **3b** and tighten with 35 Nm.

#### Connecting the trench:

Push the assembled clamping screw fitting **5** loosely over the copper pipe. Insert the support sleeve **4** into the copper pipe of the heating element. **Important:** Push the copper pipe into the angle piece **3a** or double nipple **3b** until it stops and tighten the screw fitting in this position with 40 Nm.

### 4.1.3 Deaeration

Deaeration is performed by flushing and the deaerators installed on the distribution manifold

#### 4.1.4 Control and pressure test

Once all circuits have been connected to the heating manifold, the system can be filled downstream of the manifold and pressurised. The pre-insulated Variomodular pipes are to be kept under water pressure prior to applying the screed so that any damage becomes immediately visible.

Details regarding the system and heating circuit pipes and the room temperature control are provided in the [DISTRIBUTION and CONTROL](#) planning and installation instructions >>

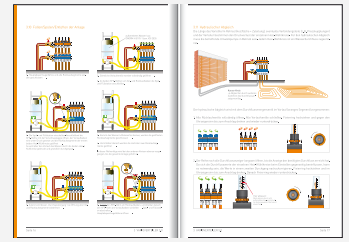

## 4.2 Hydraulic connection on 2-pipe system

In the 2-pipe system, the trench heating is piped in accordance with the laying diagram using copper pipes, for example. The flow valve is installed with integrated deaeration in the flow side and the return valve is installed in the return side.

**Caution:** For reasons of space, with the BKH2 and BKH2 mini the flow valve is installed in the return and the return valve is installed in the flow (see connection example towards the end of page 12)

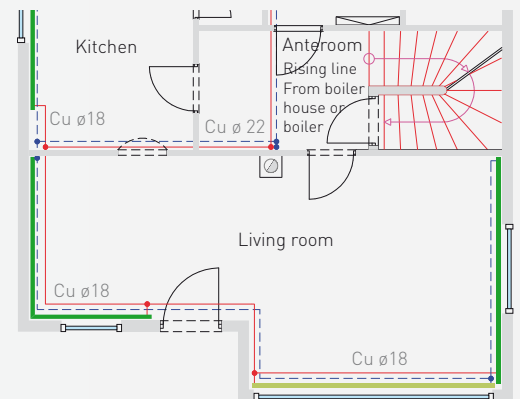
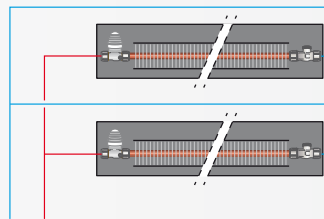

#### 4.2.1 Feed to flow and return

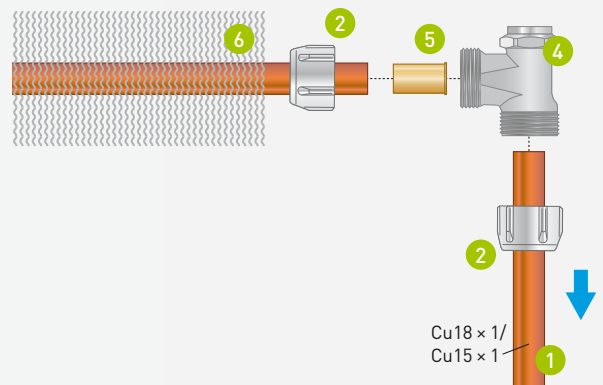
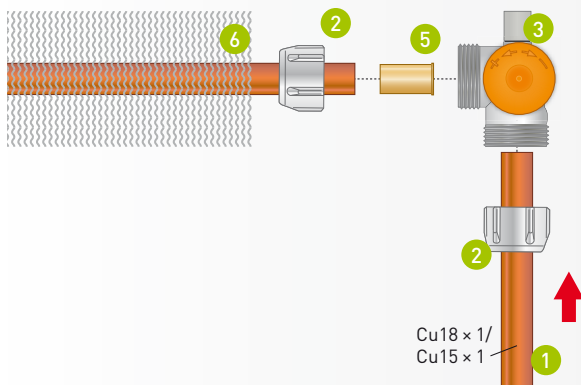

- ① E.g. copper pipe  $\varnothing$  18x1 mm
- ② 3/4" EUROxCu18 clamping screw fitting
- ③ Flow valve
- ④ Return flow valve
- ⑤ 18 x 17 mm support sleeve (only necessary with heating element with copper pipe!)
- ⑥ Heating element (with copper pipe)

Push the assembled clamping screw fitting ② loosely over the copper pipe. Insert the support sleeve ⑤ into the copper pipe of the heating element. **Important:** Cut the pipe straight/at right-angles, and push into the flow valve ③ or return flow valve ④ until the stop is reached. In this position, tighten the clamping screw fittings with 40 Nm.

#### 4.2.2 Deaeration

The individual skirting heating systems are deaerated via the flow valves with integrated manual deaeration systems. The deaeration elbow is inserted in the return for valves without integrated deaeration systems. >>

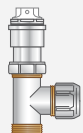

4.2.3 Flow valve

The flow valve with integrated air vent is available in left, right or continuous versions.

On delivery, there is a protective plastic cap on the valve spindle. This allows the valve to be opened or closed without a valve head. The flow valve can be used for hydronic balancing. So using the return valve for hydraulic balancing wouldn't be required no more. Before mounting a valve head or presetting the valve, the protective plastic cap is removed.

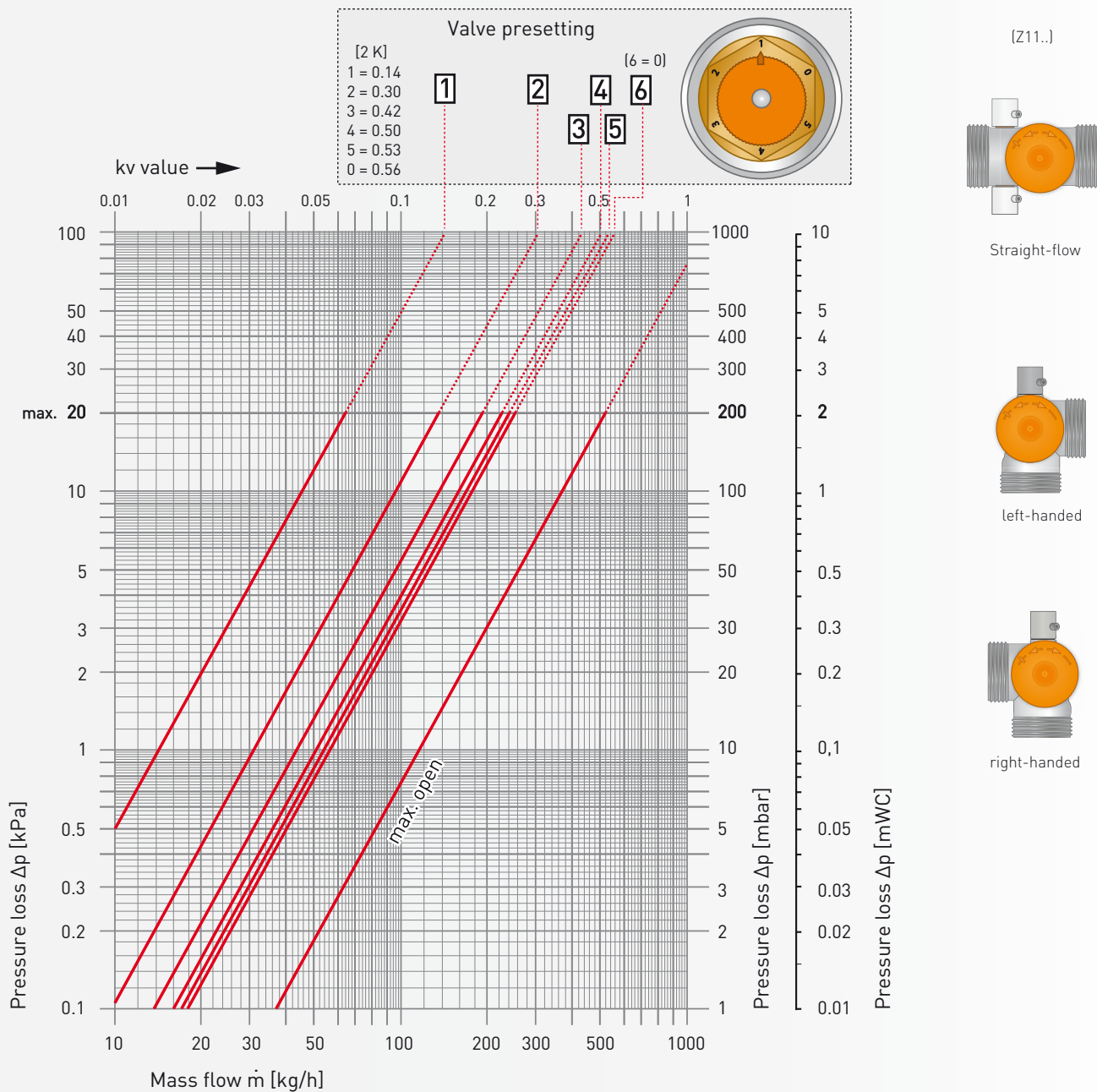

System deviation	kv value							
	0.5 K	1 K	1.5 K	2 K	2.5 K	3 K	3.5 K	4 K
Presetting 1	0.05	0.11	0.14	0.14	0.14	0.14	0.14	0.14
Presetting 2	0.13	0.25	0.29	0.30	0.30	0.30	0.30	0.30
Presetting 3	0.14	0.26	0.38	0.42	0.44	0.44	0.45	0.45
Presetting 4	0.14	0.27	0.39	0.50	0.54	0.55	0.56	0.57
Presetting 5	0.15	0.28	0.40	0.53	0.66	0.70	0.72	0.73
Presetting 6 (= 0)	0.15	0.28	0.41	0.56	0.70	0.76	0.80	0.81

Valve heads for flow valves:



Thermostat head with remote sensor



Handwheel



Thermoelectric actuator

4.2.4 Return valve

The return valve is used for hydronic balancing and as a shut-off valve if the heating elements have to be dismantled. The valve spindle is under the protective cap. The return valve can be closed by rotating it.

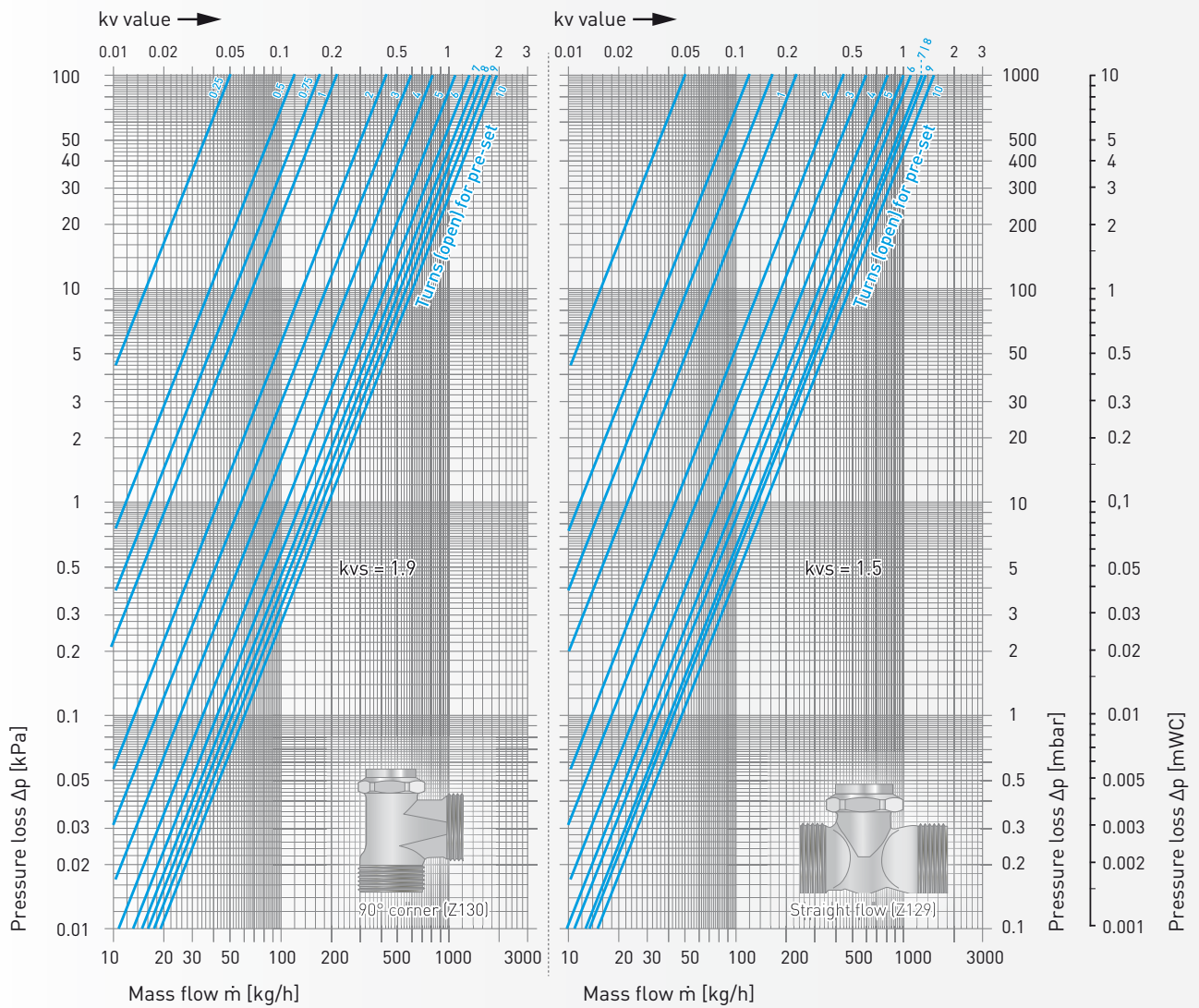

## 4.3 Connection examples

Connection to a Variotherm heating distribution manifold using a pre-insulated 16x2 Variomodular pipe:

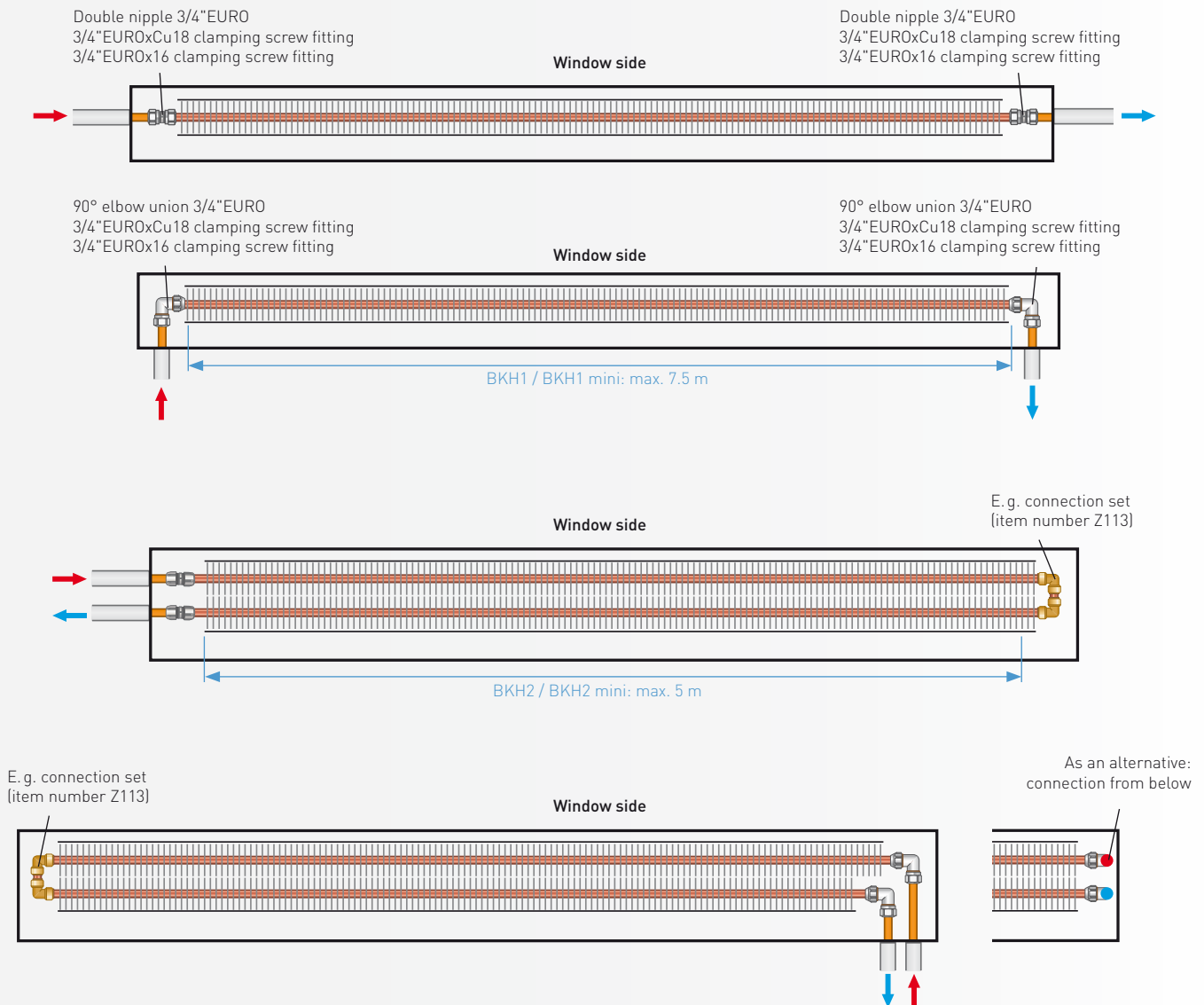

Connection to a 2-pipe system:

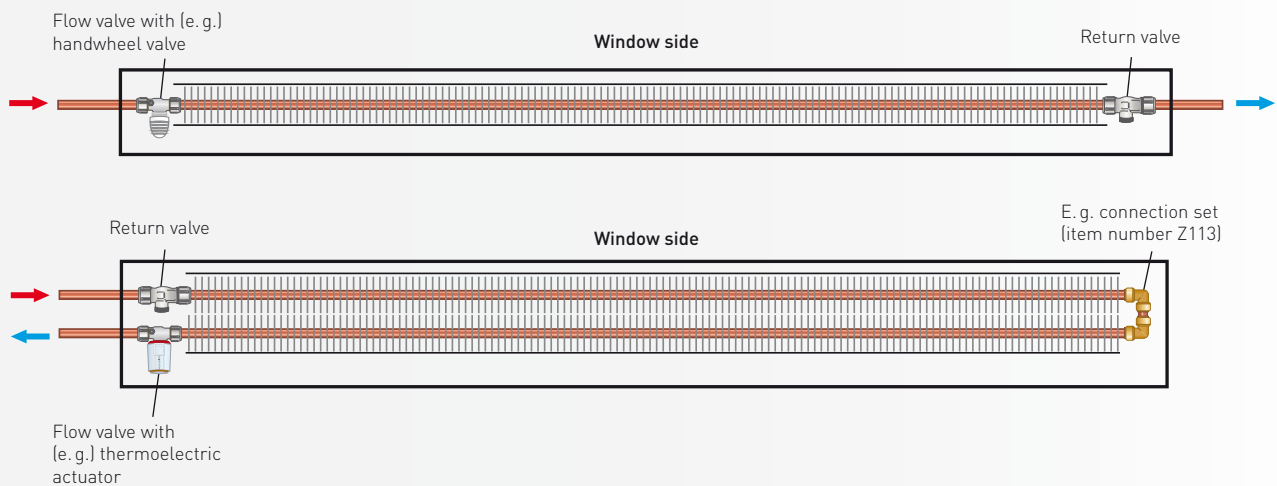

Connection to a Variotherm heating distribution manifold using a pre-insulated 16x2 Variomodular pipe:

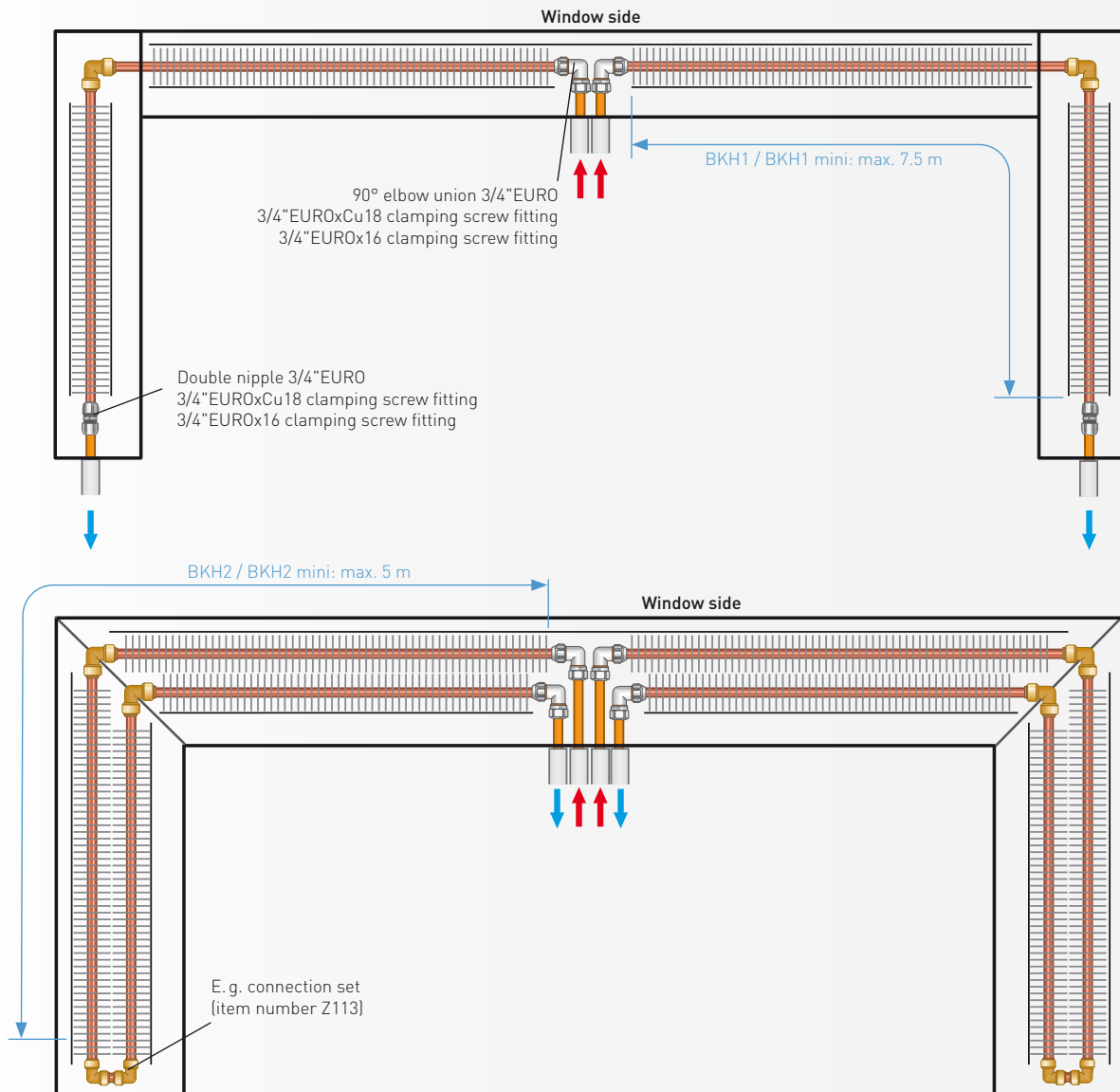

Connection to a 2-pipe system:

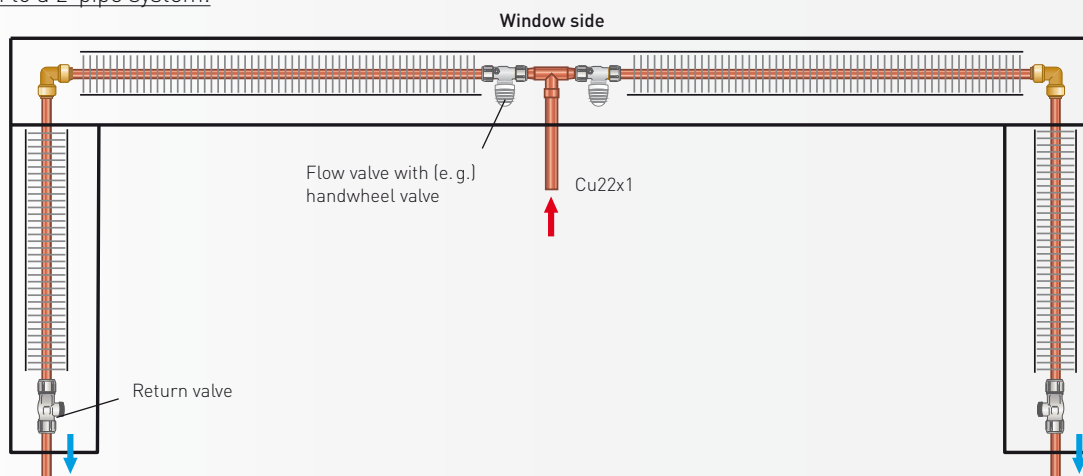

BKH2/BKH2 mini, Connection left/right:

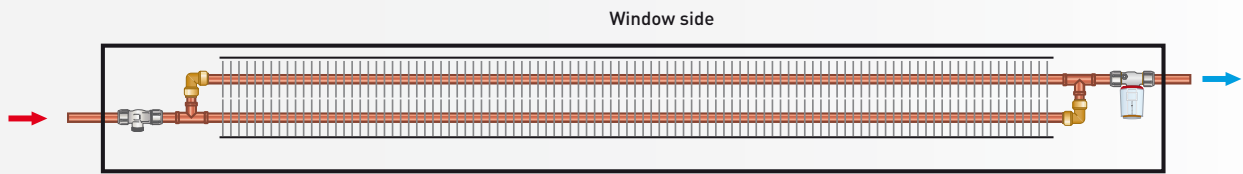

BKH2/BKH2 mini, combined:

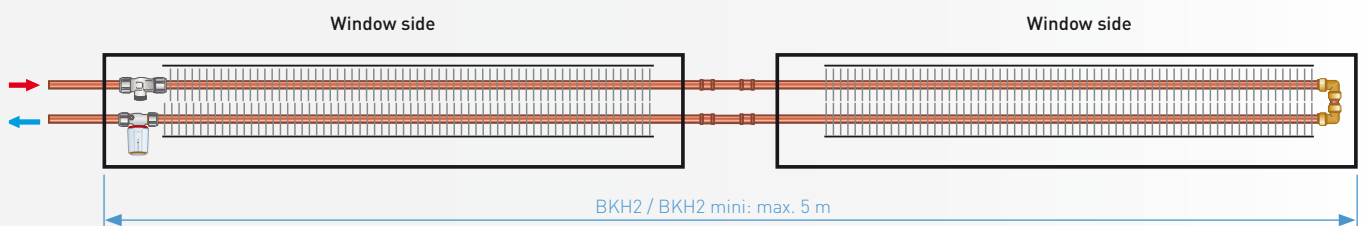

BKH2/BKH2 mini, Length maximisation to 7.5 metres



BKH1/BKH1 mini, combined:

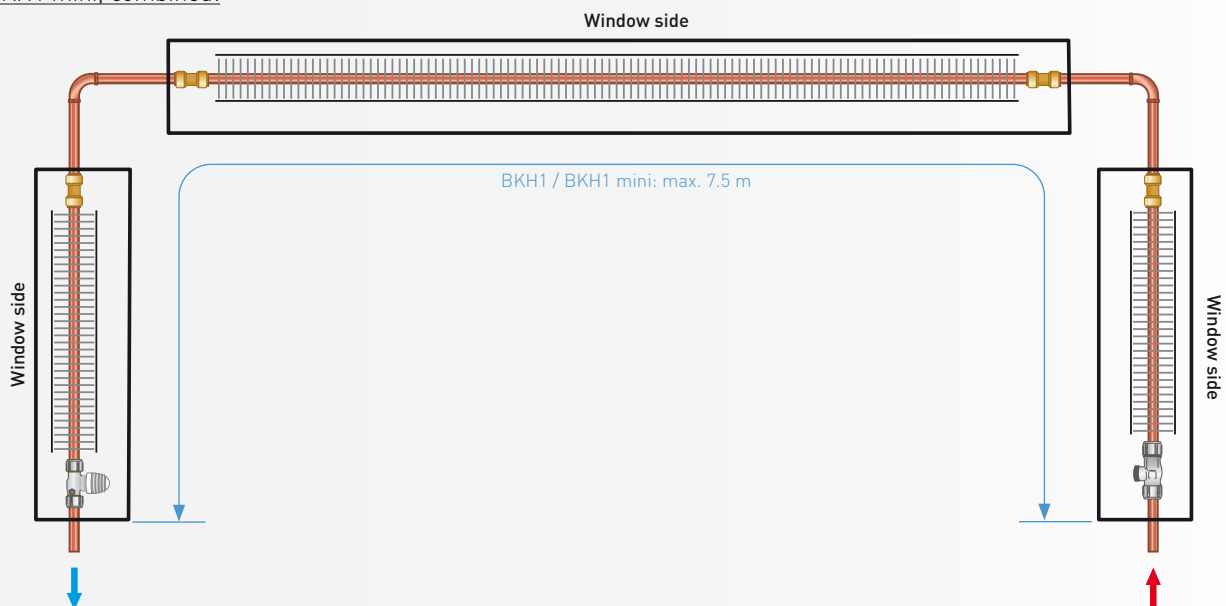

## 5.1 Leak-tightness test

The entire piping (heating elements and supply pipes) must be subjected to a pressure test before installation of the final floor covering or application of the screed. Furthermore, adequate precautions must be taken to prevent screed from entering the trench (cover all openings with suitable material). The cardboard cover provided (14 mm) must be used instead of the grid.

Construction project: \_\_\_\_\_

Building owner/Occupant: \_\_\_\_\_

Client: \_\_\_\_\_

Heating installation technician: \_\_\_\_\_

Architect: \_\_\_\_\_

Other: \_\_\_\_\_

The Variotherm trench heating circuits are to be tested for leak-tightness using a water pressure test. The test pressure should be min. 4 bar and max. 6 bar. Due to the initial pipe expansion, it may be necessary to re-pump the test pressure. If there is a risk of freezing, appropriate measures should be taken, e. g. use of antifreeze and controlling the building's temperature.

The Leak-tightness test can also be carried out with compressed air as an alternative. The test pressure in this case is max. 3 bar.

- Trench incl. grid, connection and piping completed on: \_\_\_\_\_
- Pressure test started on: \_\_\_\_\_ with test pressure of \_\_\_\_ bar
- Pressure test finished on: \_\_\_\_\_ with test pressure of \_\_\_\_ bar
- The system water was treated (e. g. per ÖNORM H 5195-1, VDI 2035)  Yes  No
- Antifreeze was added to the system water  Yes  No
- Heating started on: \_\_\_\_\_

Approval:

\_\_\_\_\_  
Building owner/Occupant/Client

\_\_\_\_\_  
Construction management/Architect

\_\_\_\_\_  
Heating installation technician

## 5.2 Commissioning

Before commissioning, remove the cardboard cover (14 mm) and insert the grid. The flow and return valves or the heating circuit shut-offs on the manifold must be opened. The entire system is to be deaerated thoroughly. The circulation pump may be switched on after deaeration. After commissioning, the Variotherm trench heating system can be considered maintenance-free.

(Subject to technical modifications without notice.)

## ENJOY THE COMFORT & SAVE ENERGY

That's why our customers love us:

Heating and cooling optimised for COMFORT in all rooms!

Fast and friendly service, ANSWERS backed up with expertise!

Always in tune with the latest technology, INNOVATION guaranteed!

Everything CLEAR and SIMPLE, in writing of course!

PROFESSIONALISM at all times, from the first contact to the reference list!

## VARIOTHERM SINCE 1979

Variotherm is an Austrian model plant with hundreds of partners in Austria, Europe and around the world.

All rights pertaining to distribution and translation, in whole or in part, including film, radio, television, video recording, Internet, photocopying and reprinting, are reserved. Subject to mistakes and printing errors.

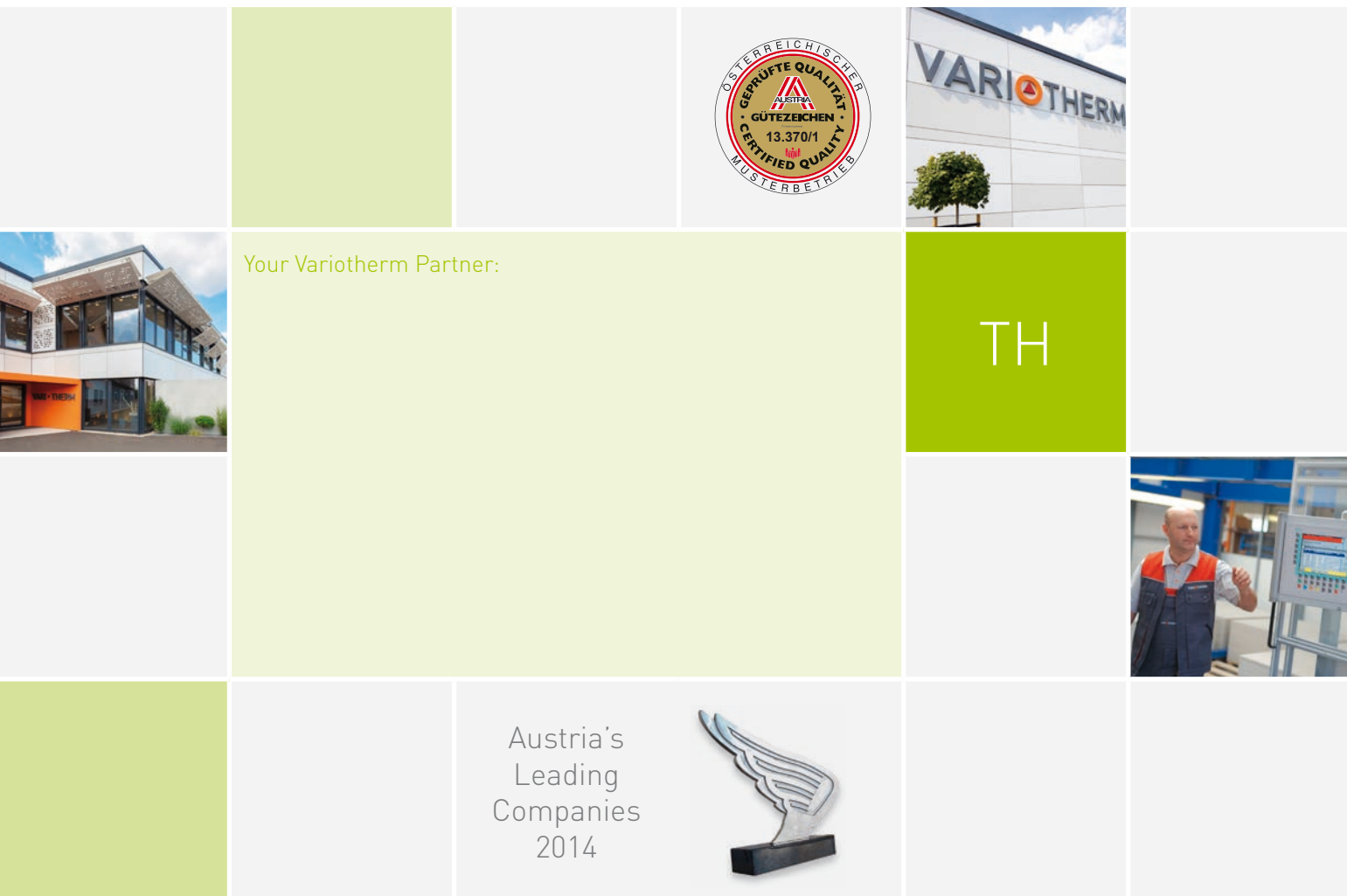

VARIOTHERM HEIZSYSTEME GMBH

GÜNSELSDORFER STRASSE 3A  
2544 LEOBERSDORF  
AUSTRIA

Phone: 0043 22 56 - 648 70-0

office@variotherm.com www.variotherm.com