

TH PLANNING

TRENCH HEATING. INDIVIDUAL.

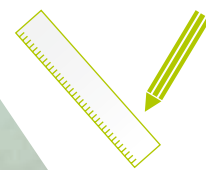

205 W
55 °C
(BKH1-2000)

BKH1. BKH1 mini.
BKH2. BKH2 mini.

TABLE OF CONTENTS

1	PRINCIPLES	4
1.1	What does a veil have to do with trench heating systems?.....	4
1.2	The Coandă effect	4
1.3	Comfort	5
1.4	Energy savings	6
1.5	Method of operation of the trench heating system	6
1.6	Description and advantages of the trench heating system.....	7
2	COMPONENTS	8
2.1	Overview.....	8
2.2	Grid.....	8
2.3	Heating elements.....	9
2.4	Connection accessories.....	9
2.5	Accessories for connection to the VarioManifold	10
2.6	Accessories for connection to the two-pipe system	11
3	PIPING WITH THE VARIOMANIFOLD	12
4	PIPING WITH A 2-PIPE SYSTEM.....	13
5	THERMAL OUTPUT	16
5.1	Calculation of the thermal load.....	16
5.2	Variotherm dimensioning software	16
5.3	Heat output tables	17
6	DIMENSIONING AND LAYOUT	18
6.1	Dimensioning of the trench heating system	18
6.2	Delivery times	18
6.3	Mitres	18
6.4	Free accessibility	18
6.5	Air connection.....	19
6.6	Installation examples.....	19
7	CONNECTION EXAMPLES	20

1 PRINCIPLES

1.1 What does a veil have to do with trench heating systems?

A veil has a simple function: It blocks something. The same applies to the hot air veil created by the Variotherm trench heating system, which covers cold glass surfaces within a short period of time. This shields the “cold radiation” from the glass surfaces. When this happens, a feeling of cosiness starts spreading throughout the room, replacing the cold.

1.2 The Coandă effect

The Coandă effect is a physical requirement for the effect produced by the trench heating system. At the beginning of the 20th century, physicist Henri Coandă discovered that rising hot air always follows cold surfaces (e.g. glass surfaces and exterior walls) as it ascends: When air currents exit slits at a certain angle and distance, the current will bend towards the surface due to the created turbulences and the lower pressure on one side. The air current will “stick” to it as long as certain requirements (distances and flow thickness) are met. The low pressure area around the secondary air introduced by the flow over a surface is crucial for this effect. If this air cannot continue to flow, the current will draw itself into this area, or follow the glass surface. This law of physics is the reason why the Variotherm trench heating system works in such an outstanding way. Thanks to the Coandă effect, trench heating systems also have another advantage: Only a small amount of dust is stirred up because the heating system generates only a very small amount of air movement.

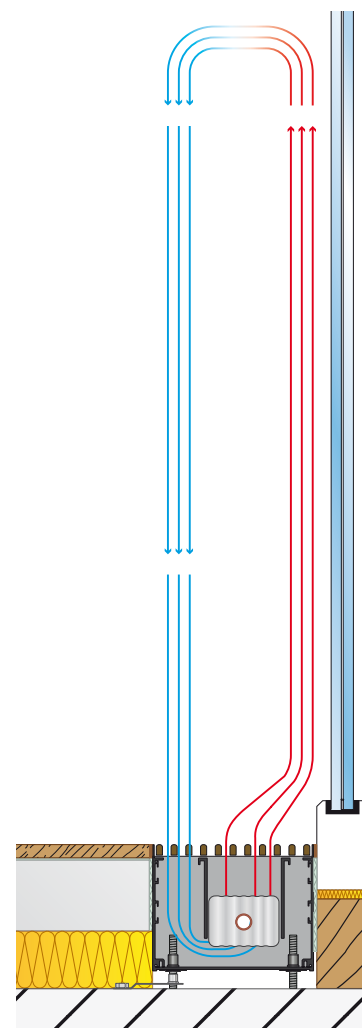

▲ Coandă effect

1.3 Comfort

Compared to other heating systems, a trench heating system increases cosiness. The unpleasant influence of the cold glass surfaces (radiation exchange with the body) is largely cancelled out by the positioning of the trench heating system in front of the cold glass surfaces. You can set the room temperature lower than you would with convection heating without worrying about discomfort, since the hot air veil raises the perceived air temperature.

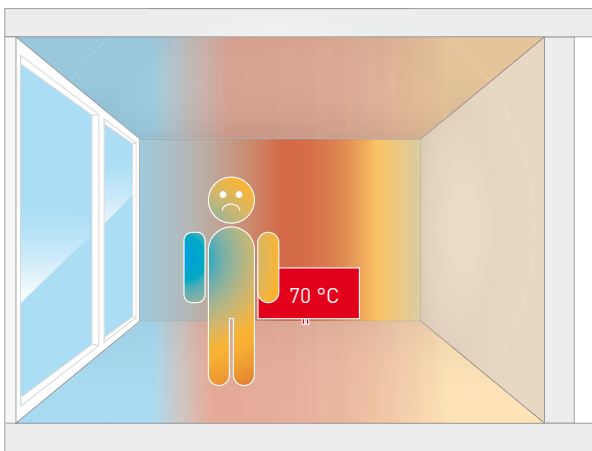

Discomfort with radiators:

Heated air rises quickly and returns to the floor as cold air. In addition, the cold radiation from the glass surface has a negative effect on the body. → Unbalanced temperature distribution, stirred dust caused by circulating air, “dry air”

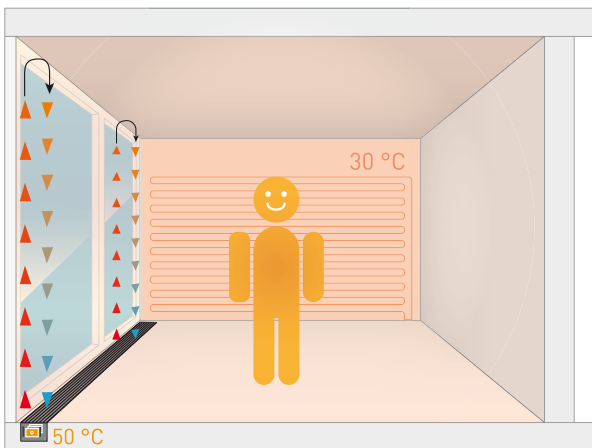

Comfort with the Variotherm

trench heating system and wall heating:

The even heating of the walls creates a cosy warmth enveloping the entire room. → Healthy room climate, hardly any dust stirred up, no over-heated floor, no overheated ceiling, “very cosy”

1.4 Energy savings

Energy losses are significantly reduced through an optimised ambient air temperature in conjunction with increased comfort. The approximate cost savings are 6 % per 1 °C reduction of room air temperature. This has the additional great physiological advantage of significantly increasing the absorption of oxygen in the body. At the same time, the relative humidity increases and produces healthier air that is also easier to breathe. Compared with other hot water heating systems, trench heating systems run with the lowest amount of water. They are therefore the fastest and most precise hot water heating systems.

1.5 Method of operation of the trench heating system

The goal of a trench heating system is to maintain the right glass surface temperature. For this reason, wherever possible they are installed in front of all floor-touching glass surfaces, such as winter gardens or glass sliding terrace doors. The air flows from bottom to top through the trench heating system and then selects the area right next to the wall as a channel to ascend along due to the higher temperature difference (see also Coandă effect, section 1.2). While ascending, it continuously radiates its heat to the glass surface before stratifying within the room air. The heated surface turns into a heat radiating surface. This provides a cosy indoor temperature with low temperature differences within the room, and between the glass surfaces and interior wall surfaces.

Trench heating systems are suitable for new homes and renovations. They can be installed in conventional 2-pipe systems or manifold systems. When renovating, existing rising lines can be used for supply.

1.6 Description and advantages of the trench heating system

The trench heating systems are optimally suited for shielding glass surfaces in new buildings and renovated buildings.

The trench heating system is supplied pre-assembled, ready for installation. All components are perfectly matched to each other.

- Floor trench: Aluminium side walls and end cover (black anodised), black-grey aluminium base, air baffles, heating element mounting bulkheads, interior adjustment screws for height adjustment, green side strips, attachment brackets
- Length: Custom length (with lengths > 5000 mm, the floor trench is supplied in segments)
- Grid: Linear or roll grid, anodised aluminium, safe to walk on, standard colours: Plain aluminium (EV 1), light bronze (C 32), black (C 35)
- Heating element: Copper pipe $\varnothing 18 \times 0.5$ mm (DIN EN 12449) with 56×78 mm aluminium louvres

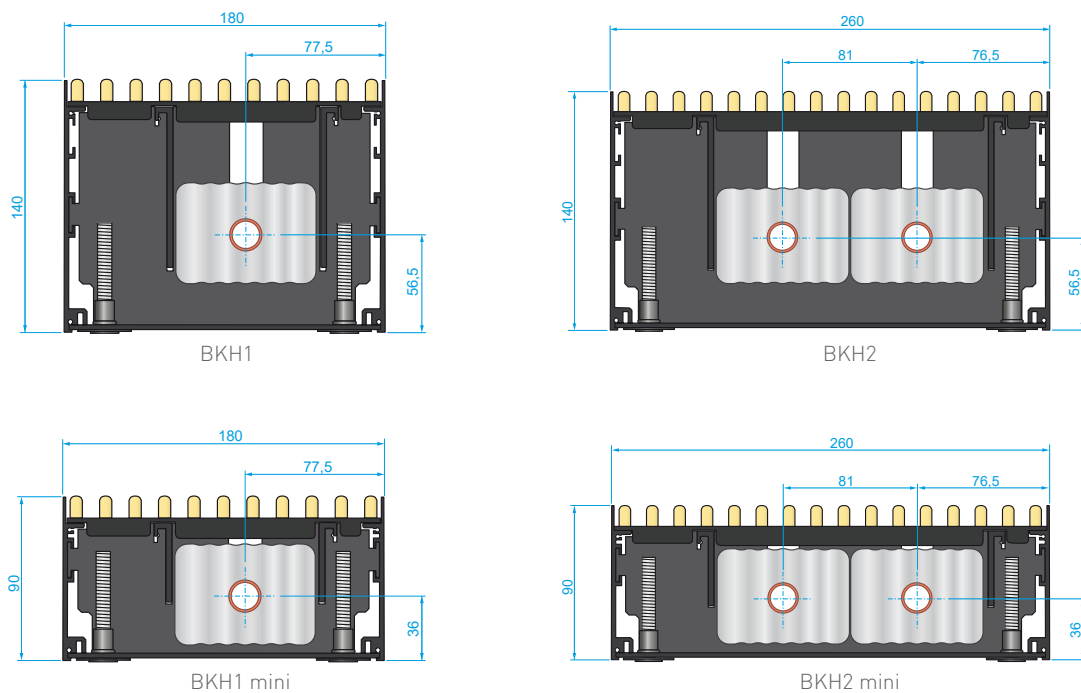

The advantages:

- Elegant, discrete and flexible design
- Roll or linear grids in 3 different colours
- Rapidly forms a veil of warm air along cold glass surfaces
- Low hot water temperature – impressive energy savings
- Different types available to suit the structural situation
- Lengths are produced exactly to your requirements
- Short delivery lead times, despite tailor-made manufacture

2 COMPONENTS

2.1 Overview

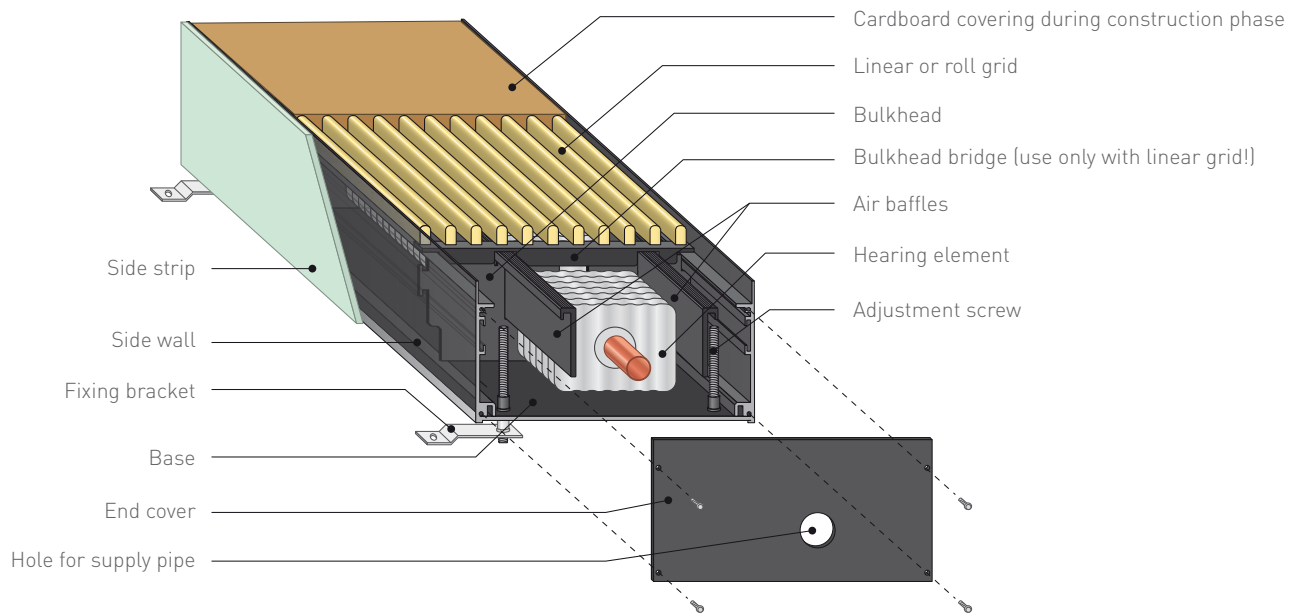

All Variotherm trench heating systems are delivered already pre-assembled with the correct length, and only need to be aligned and screwed into place at the designated site. Variotherm flow and return valves or 3/4" connection angle pieces can also be optionally pre-fitted to the pre-insulated VarioModular pipe.

The supply line holes are drilled in the end cover or side walls, as desired by the customer.

2.2 Grid

Both the linear grid and the roll grid have an attractive visual design and are easy to clean. The grids are available in 3 different colours (anodised aluminium).

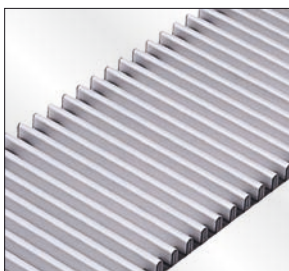

▲ EV 1: Plain aluminium

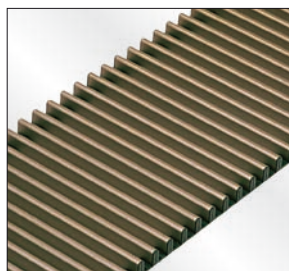

▲ C 32: Light bronze

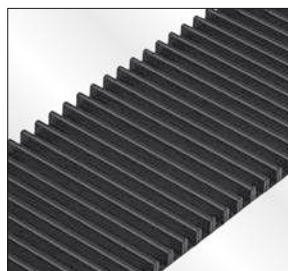

▲ C 35: Black

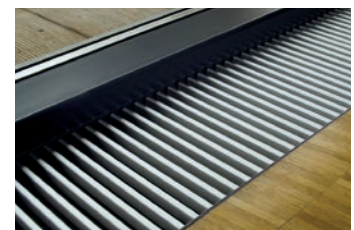

▲ Roll grid

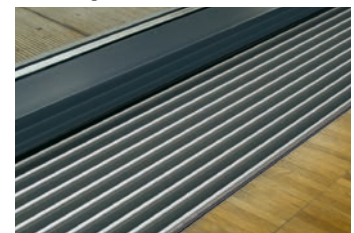

▲ Linear grid

2.3 Heating elements

The specially developed heating elements from Variotherm are the technical core component of the Variotherm trench heating system. Highly efficient when it comes to performance. Optimised heat distribution.

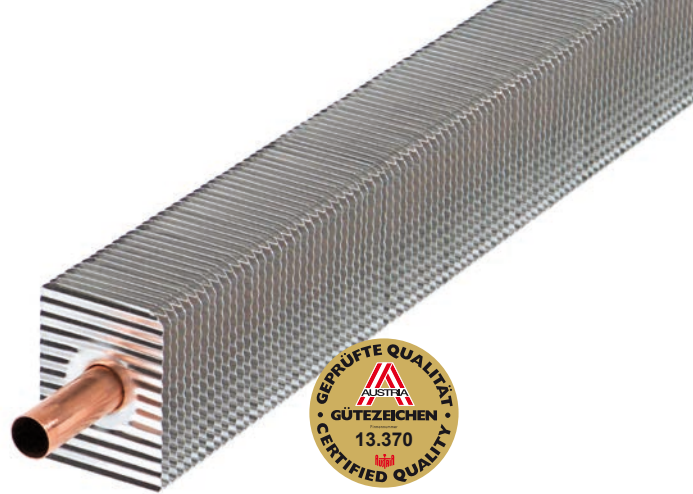

The heating element consists of a copper pipe $\varnothing 18 \times 0.5$ mm (DIN EN 12449) with aluminium louvres 56×78 mm. The special manufacturing process results in a connection between the pipe and the aluminium louvres with an unsurpassed performance.

Pipe material	Support bracket	Viega		Sanha	
		Press fitting	Press-fitting jaws	Press fitting	Press-fitting jaws
Copper	Yes	Profipress Sanpress	V18	Pressfitting Serie 6000/8000	SA18

▲ Table for suitable press fittings

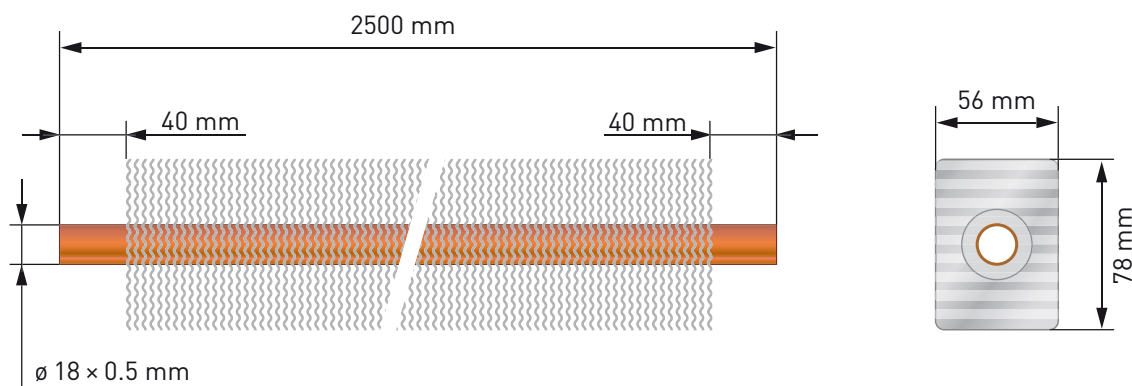

2.4 Connection accessories

Support sleeve 18 x 17 mm

for the heating element with copper pipe, used for clamping screw fittings and copper press-fit connectors

PG 062



Part No.	PKU	Weight/PKU
Z133	1 pce.	6 g

Connection set for BKH2 / BKH2 mini

for connecting two heating elements. Centre to centre 81 mm. Consisting of 2 pcs. push-in fitting elbow $90^\circ 18$ (i/i) [F921] and 1 pce. 60 mm copper pipe 18×0.5 mm

PG 062

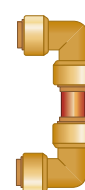

Part No.	PKU	Weight/PKU
Z113	1 set	163 g

2.5 Accessories for connection to the VarioManifold

Pre-insulated 16x2 VarioModular pipe

PG 130

- Aluminium multi-layer composite pipe 16x2 (PE-RT/AL/PE)
- No oxygen diffusion whatsoever
- 70 °C, 6 bar
- Insulation: Polyethylene soft foam
Fire resistance as per EN 14313: C_L-s1,d0

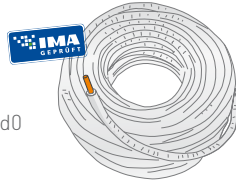

Part No.	Insulation thickness	PKU	Weight/PKU
V1226	6 mm	Roll with 100 m	14.0 kg
V1227	9 mm	Roll with 100 m	14.9 kg

Clamping screw fitting 3/4"EUROx16

PG 100

Especially developed for the Variotherm pipes 16x2 on a 3/4" Eurocone, nickel plated, single-piece, with metal clamping ring and galvanic isolation, AF 30, tested according to EN 21 003



Part No.	PKU	Weight/PKU
Z1400	1 pce.	80 g

3/4"EUROxCu18 clamping screw fitting

PG 100

nickel plated, with EPDM sealing element, for ø 18 mm copper pipes as per DIN EN 1057 and ø 18 mm stainless steel pipes as per DIN EN 10312, pipe wall thickness ≥ 1 mm



Part No.	PKU	Weight/PKU
Z136	1 pce.	60 g

Retaining clamp ø35

PG 130

for affixing the pre-insulated Vario-Modular pipes.



Part No.	Variant	PKU	Weight/PKU
V2802	single	50 pcs.	1 kg
V2803	double	25 pcs.	1 kg

Elbow union

PG 100

90° elbow connector, clamping screw fitting Cu 18 for the heating element (incl. support sleeve), 3/4" Eurocone for the connection line. (Do not forget the clamping screw fitting!)

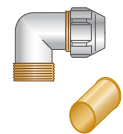

Part No.	PKU	Weight/PKU
Z38	1 pce.	260 g

Double nipple 3/4"EURO

PG 100

nickel-plated, 3/4" Eurocone on 3/4" Eurocone



Part No.	PKU	Weight/PKU
Z170	1 pce.	60 g

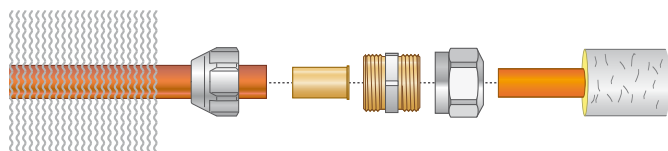

Heating element

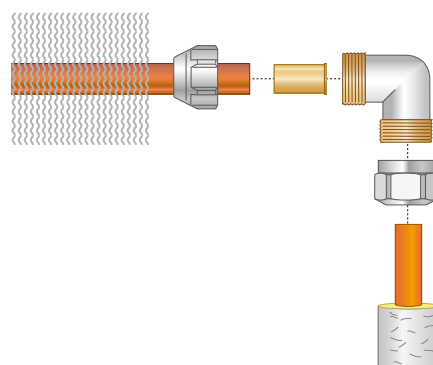

2.6 Accessories for connection to the two-pipe system

Flow valve with top piece

PG 062

1/2" valve with air vent, can be pre-set, with top piece at option, incl. clamping screw fitting 3/4" EUROxCu18 (Z136) + support sleeve (Z133) for the heating element, 3/4" Eurocone for the connection line (do not forget the clamping screw fitting!)

Thermostatic valve with remote sensor (5 m cable)



Handwheel



Actuator



<p>1/2" valve, Straight-flow, two air vents</p>	<p>Part No. Z114V</p>	<p>Part No. Z115</p>	<p>Part No. Z114S</p>
<p>1/2" valve, left-hand, one air vent</p>	<p>No additional top piece possible. Valve adjustment can be done with protective cap. (Special-purpose solutions on request)</p>		
<p>1/2" valve, right-hand, one air vent</p>			

Return valve

PG 062

1/2" valve incl. clamping screw fitting Cu 18 for the heating element (with support sleeve), 3/4" Eurocone for the connection line (do not forget the clamping screw fitting!), can be pre-set

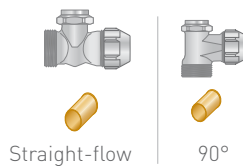

Part No.	Design	PKU	Weight/PKU
Z129	Straight-flow	1 pce.	200 g
Z130	90° corner	1 pce.	200 g

3/4" EUROxCu18 clamping screw fitting

PG 100

nickel plated, with EPDM sealing element, for \varnothing 18 mm copper pipes as per DIN EN 1057 and \varnothing 18 mm stainless steel pipes as per DIN EN 10312, pipe wall thickness \geq 1 mm



Part No.	PKU	Weight/PKU
Z136	1 pce.	60 g

3/4" EUROxCu15 clamping screw fitting

PG 100

nickel plated, with EPDM sealing element, for \varnothing 15 mm copper pipes as per DIN EN 1057 and \varnothing 15 mm stainless steel pipes as per DIN EN 10312, pipe wall thickness \geq 1 mm



Part No.	PKU	Weight/PKU
Z139	1 pce.	60 g

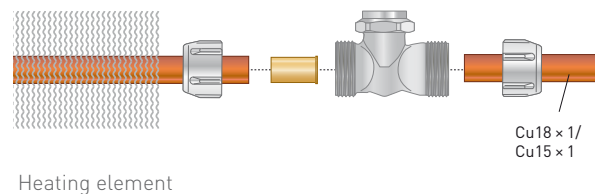
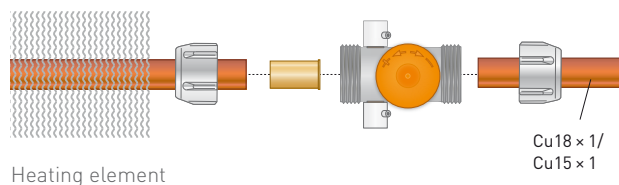

3 PIPING WITH THE VARIOMANIFOLD

For installations with manifold systems, first lay the pre-insulated VarioModular pipes from the manifold to the trench heating and back, and then connect them to the manifold. The VarioModular pipe should be routed "endlessly" (i.e. without additional connection points) from the manifold to the skirting heating.

Electronic room thermostats and servomotors are used to control the room temperature.

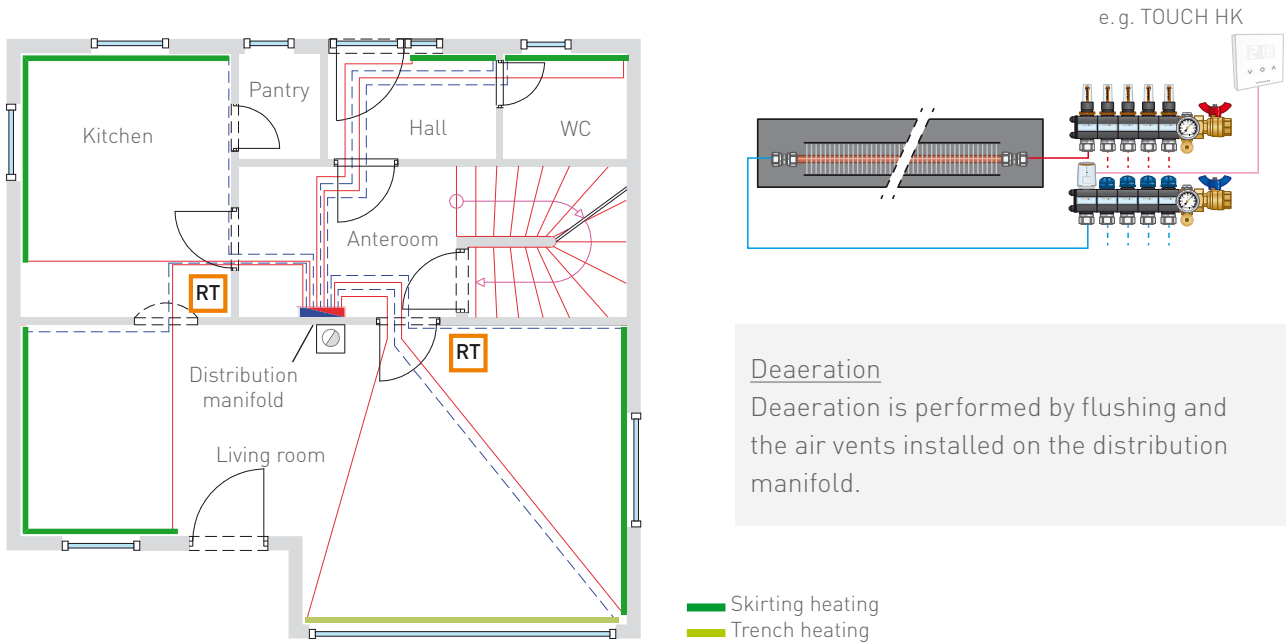

▲ Laying example with Variotherm distribution manifold

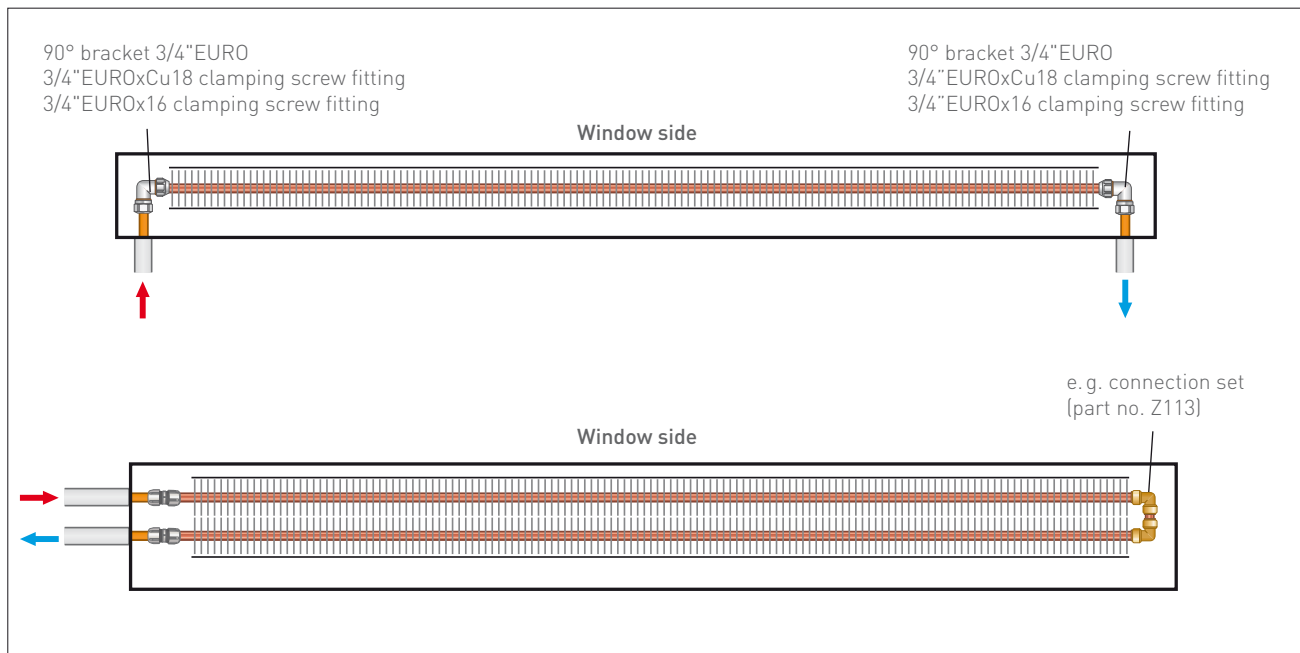

▲ Connection examples (more examples see chapter 7)

4 PIPING WITH A 2-PIPE SYSTEM

In the 2-pipe system, the trench is piped using (e.g.) copper pipes. Flow valves with integrated deaerators are used to control the room temperature. The return valves are used to shut off and set the water quantity (hydraulic balancing).

Note: For reasons of space, with the BKH2 and BKH2 mini the flow valve is installed in the return and the return valve is installed in the flow (see connection example on page 20 below).

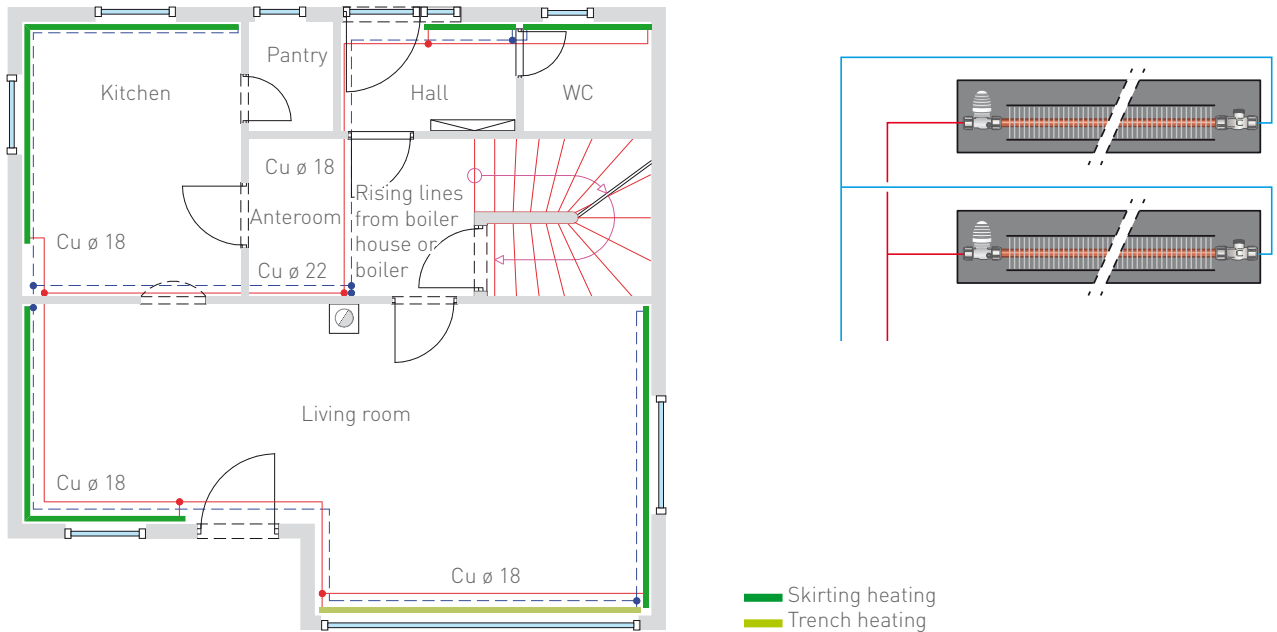

▲ Laying example with 2-pipe system

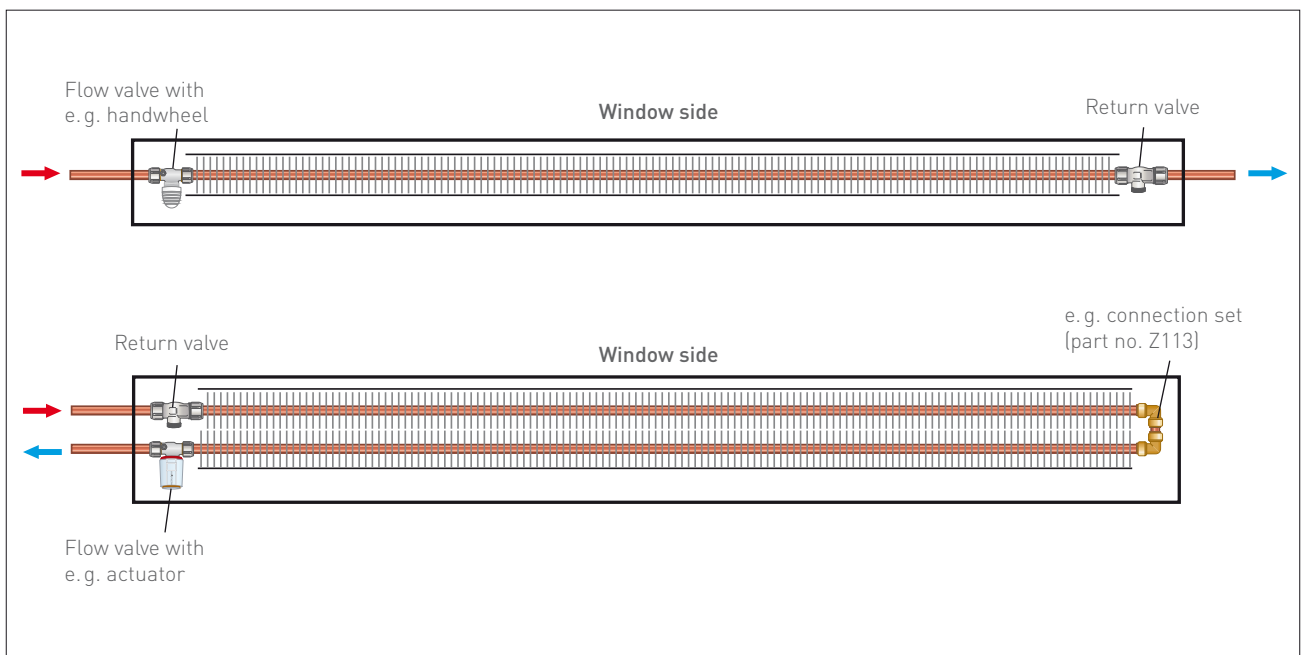

▲ Connection examples (more examples see chapter 7)

3 Flow valve

The flow valve with integrated air vent is available in left, right or continuous versions.

On delivery, there is a protective plastic cap on the valve spindle. This allows the valve to be opened or closed without a valve head. The flow valve can be used for hydronic balancing. So using the return valve for hydraulic balancing wouldn't be required no more. Before mounting a valve head or presetting the valve, the protective plastic cap is removed.

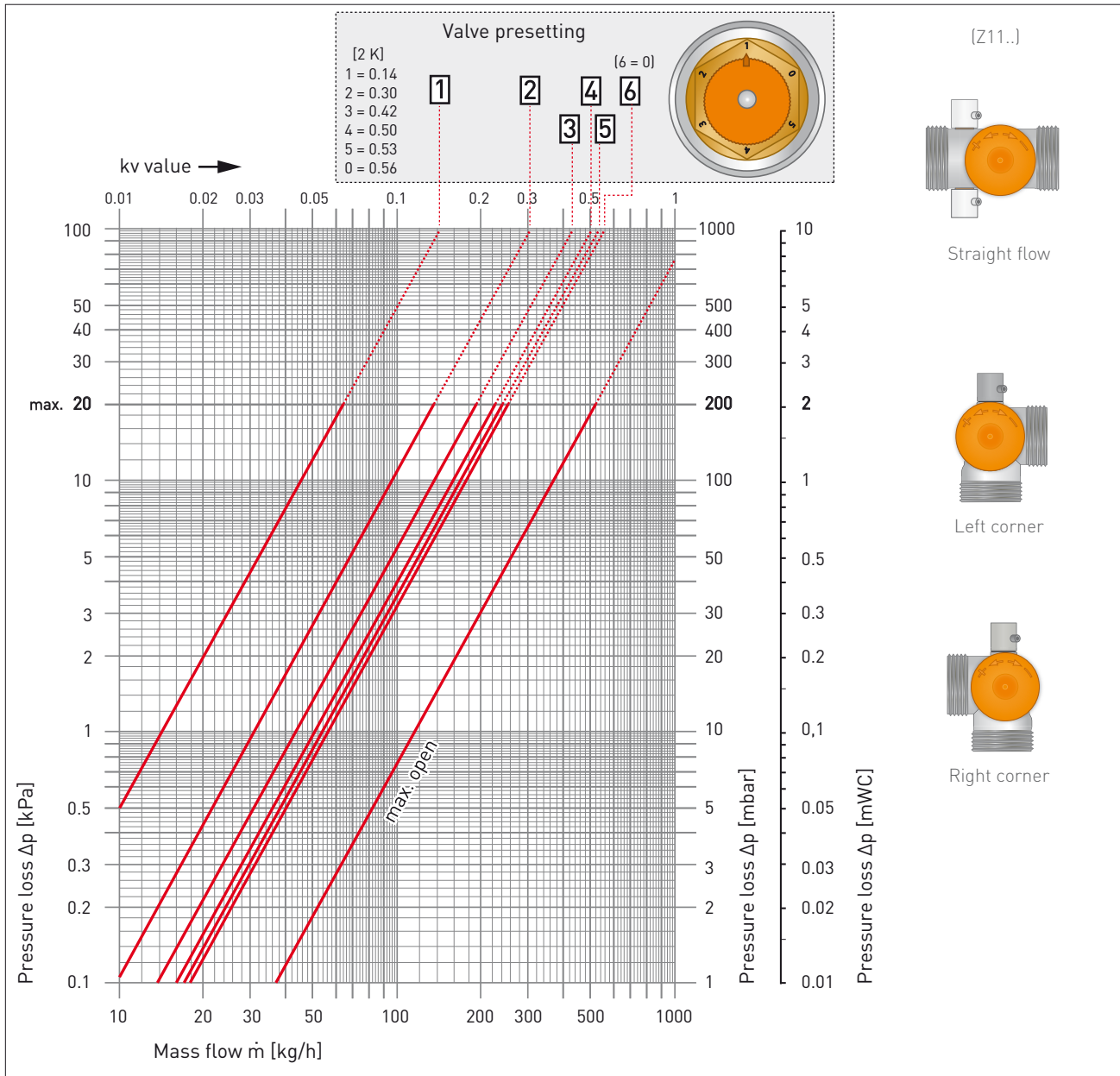

	kv value							
System deviation	0.5 K	1 K	1.5 K	2 K	2.5 K	3 K	3.5 K	4 K
Presetting 1	0.05	0.11	0.14	0.14	0.14	0.14	0.14	0.14
Presetting 2	0.13	0.25	0.29	0.30	0.30	0.30	0.30	0.30
Presetting 3	0.14	0.26	0.38	0.42	0.44	0.44	0.45	0.45
Presetting 4	0.14	0.27	0.39	0.50	0.54	0.55	0.56	0.57
Presetting 5	0.15	0.28	0.40	0.53	0.66	0.70	0.72	0.73
Presetting 6 (=0)	0.15	0.28	0.41	0.56	0.70	0.76	0.80	0.81

Valve heads for flow valves:

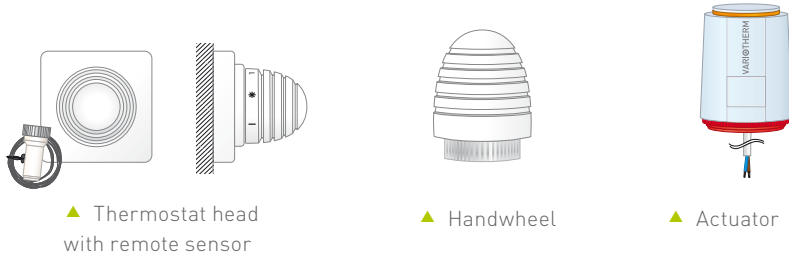

4 Return valve

The return valve is used for hydronic balancing and as a shut-off valve if the heating elements have to be dismantled. The valve spindle is under the protective cap. The return valve can be closed by rotating it.

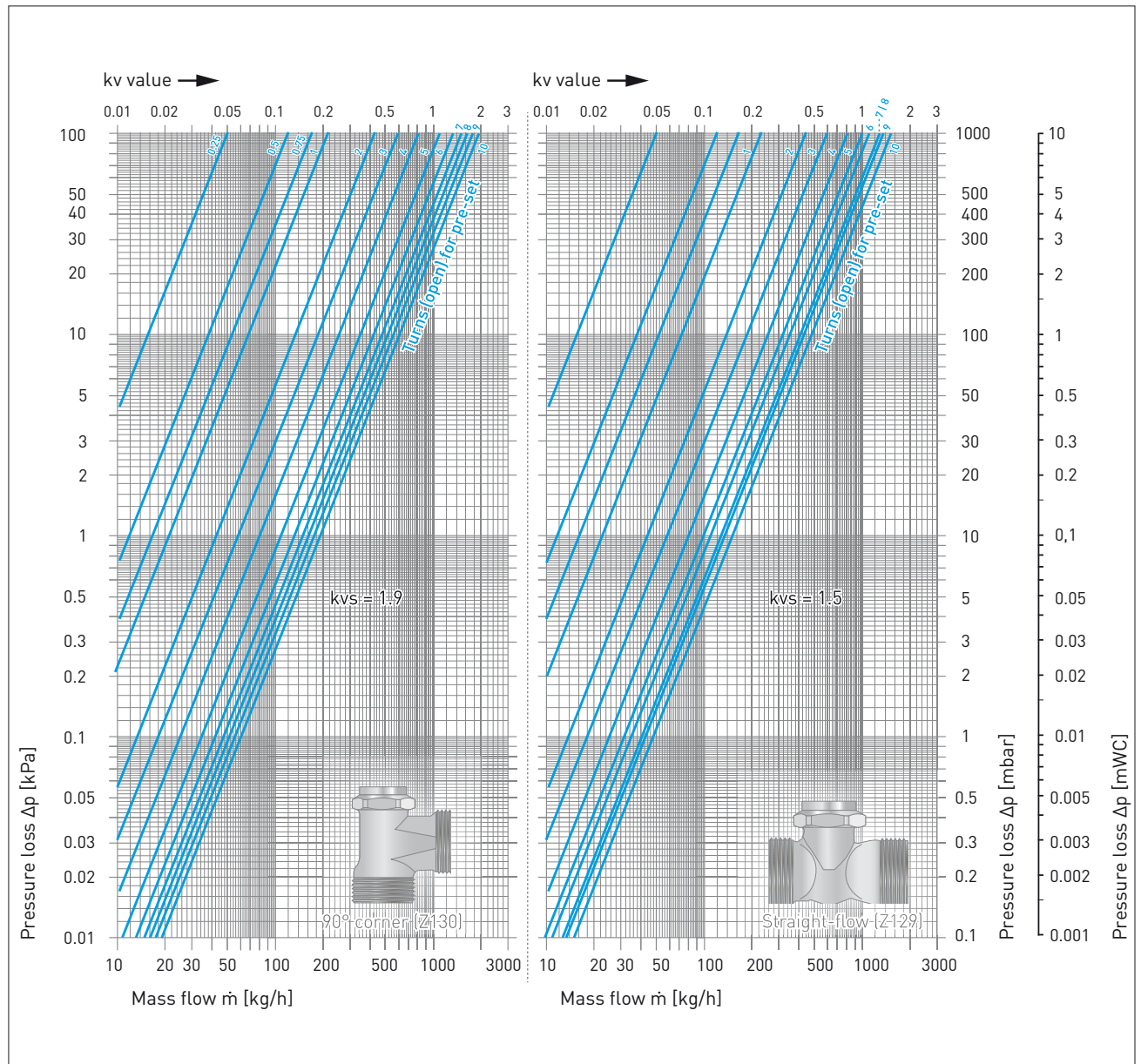

5 THERMAL OUTPUT

5.1 Calculation of the thermal load

Along with the respective national annex, the EN 12831 standard will be used to calculate the heating load for the heated rooms.

Every room is considered individually. For the outside temperature, the locally acquired and standardised outdoor temperature T_{ne} is used.

Übersicht der Bauteile

Code	Bezeichnung	U-Wert W/m²K	Rges m²K/W	Rsi m²K/W	Rse m²K/W	R-Baut m²K/W
AF01	Außenfenster	1.100	0.909	0.130	0.040	0.739
AT01	Außentür	1.700	0.588	0.130	0.040	0.418
AW01	Außenwand	0.220	4.545	0.130	0.040	4.375

Raum		$\Theta_{s,i}$	$A_{s,i}$	$\Phi_{s,i}$	$\Phi_{t,i}$	$\Phi_{v,i}$	Φ_{Verlust}^*	Φ_{Rohrnet}	Φ_{Rohr}	Φ_{Rohr}	Φ_{HL}
Nr.	Bezeichnung	°C	m²	W	W	W	W	W	W	W	W
Haus_EG			180.88	5427		3396			9160	0	9160
00.001.001	Ehem	20.0	29.10	833	833	501		46	15	1335	0
00.001.002	Kinder	20.0	20.49	762	762	343		54	19	1106	0
00.001.003	Vorraum	20.0	24.40	571	571	409		40	14	980	0
00.001.004	Bsp	20.0	19.92	594	594	420		21	8	993	0

▲ Extract from a heating load calculation

5.2 Variotherm dimensioning software

Key values for individual heating circuits (the amount of water, pressure loss, number of circuits, allocation of the manifolds etc.) can be quickly and easily calculated by inputting the heating load into the Variotherm dimensioning software. It can be found in our Professional Area at www.variotherm.com/profi.

Dimensioning of Variotherm Heating Systems

Building project: Sample ZP: 2544 City: Leobersdorf Date: Processed by:

No. Room name	Floor space [m²]	Maximum length of SH [m]	Heating load [W]	Supplement [%]	Heating load incl. Supplement [W]	Room temp. [°C]	Heating system	Floor covering [m²] or pipe covering [m]	Dimensioning temperature [°C]	Mathematical				Practical				Supply pipe	Supply line length [m]	Pressure loss [mWC]	Flow quantity [l/h]	Distribution manifold number	Calculation of pressure loss and flow rate with 2 systems at one heating circuit (see manual)
										Dim.	Unit	Type	No. of circuits	Dim.	Unit	Type	Residual performance						
Conservatory	25.00	15.00	2245		2245	20	Ducted channel heating	55	15.00	m	BKH2	3	5,00	m	BKH2	404	-	0.02	90	1			
Home office		3,00	842		842	20	Skirting heating	55/45			HL IIa	1	3,00	m	HL IIa	106	-	0,00	82	1			
Aisle		1,50	123		123	20	Skirting heating	55/45			HL Ia	1	1,50	m	HL Ia	230	-	0,00	31	1			

Summary of the heating systems

Amount	Unit	Heating system	Type	Pipe / Heating element
m²		System wall heating	SWHK2	
m²		System wall heating	SWHK2	
m²		Modular wall heating	MSW	
m²		EasyFlex wall heating	EWHK77	
m²		EasyFlex wall heating	EWHK15	
m²		Modular ceiling heating	MSD/MRD	
m²		Screened floor heating	RA10	
m²		Screened floor heating	RA15	
m²		Screened floor heating	RA20	
m²		Screened floor heating	RA25	
m²		Screened floor heating	RA30	
m²		Compact floor heating	RA10	
m²		Compact floor heating	RA20	
m²		Industrial floor heating	RA20	
m²		Industrial floor heating	RA25	
m²		Industrial floor heating	RA30	
m²		Industrial floor heating	RA35	
m²		Industrial floor heating	RA40	
m		Skirting heating	HL mini	
1,5	m	Skirting heating	HL Ia	1,5 m
3,0	m	Skirting heating	HL IIa	3,0 m
m		Skirting heating	HL IIa	
m		Ducted channel heating	BKH1 mini	
m		Ducted channel heating	BKH1	
m		Ducted channel heating	BKH2 mini	
15,0	m	Ducted channel heating	BKH2	30,0 m
m		Supply pipe	16x2	
m		Supply pipe	11,6x1,5	
m		Supply pipe	20x2	

Summary of pipe length by line

Room name	Ø 20 (m)	Ø 16 (m)	Ø 11,6 (m)	HL18 (m)	HLm18 (m)
Conservatory				30,0	
Home office				3,0	
Aisle				1,5	
Total				34,5	

Line	Number of heating circuits	Flow quantity manifold [l/h]	Pressure loss for manifold [mWC]	Manifold rotation according to drawing
Distribution manifold #1	55/45	5	383	0,1
Distribution manifold #2				
Distribution manifold #3				
Distribution manifold #4				
Distribution manifold #5				
*Note: If two distribution manifolds are fed via one pump, the following applies:				
Total flow quantity:			383 l/h	
Maximum pressure loss from distribution manifold incl. 0.1mWC for max. opened valve			0.12 mWC	
Summary of the floor heating surface area:				
Screened floor heating			0.0 m²	
Compact floor heating			0.0 m²	
Industrial floor heating			0.0 m²	
Summary of loads:				
Total heating load			3.210,0 W	
Total installed load			3.950,0 W	
Total filling water:				
Total filling water			7,8 l/m³	
Notes:				

▲ Variotherm dimensioning software example for heating

5.3 Heat output tables

Length [mm]	Type	Heat output [W/pc.] at flow temperature t_f ... [recommended range: 45–60 °C]									
		... 40 °C	... 45 °C	... 50 °C	... 55 °C	... 60 °C	... 65 °C	... 70 °C	... 75 °C	... 80 °C	... 85 °C
1000	BKH1 mini	48	55	65	78	94	114	136	162	190	222
	BKH1	50	62	76	94	115	140	168	199	233	271
	BKH2 mini	49	74	99	124	149	174	199	224	249	274
1250	BKH2	56	86	116	145	175	205	234	264	294	323
	BKH1 mini	62	71	84	101	122	147	176	209	246	287
	BKH1	65	80	99	122	149	181	217	257	302	350
1500	BKH2 mini	65	98	131	164	197	229	262	295	328	361
	BKH2	74	113	152	191	230	270	309	348	387	426
	BKH1 mini	76	87	103	124	150	181	217	257	302	353
1750	BKH1	80	98	121	150	183	222	266	316	370	430
	BKH2 mini	81	122	163	203	244	285	325	366	407	448
	BKH2	92	140	189	237	286	334	383	431	480	528
2000	BKH1 mini	90	104	123	148	178	215	257	305	359	418
	BKH1	95	116	144	178	217	264	316	374	439	510
	BKH2 mini	97	146	194	243	291	340	389	437	486	534
2250	BKH2	110	168	226	284	341	399	457	515	573	631
	BKH1 mini	105	120	142	171	206	248	297	352	415	483
	BKH1	110	135	166	205	252	305	365	433	508	590
2500	BKH2 mini	113	169	226	282	339	395	452	508	565	621
	BKH2	128	195	262	330	397	464	532	599	666	733
	BKH1 mini	119	136	161	194	234	282	337	400	471	549
2750	BKH1	125	153	189	233	286	346	415	491	576	669
	BKH2 mini	129	193	257	322	386	450	515	579	644	708
	BKH2	146	222	299	376	452	529	606	683	759	836
3000	BKH1 mini	133	152	180	217	262	315	377	448	527	614
	BKH1	140	171	212	261	320	387	464	550	645	749
	BKH2 mini	144	217	289	361	433	506	578	650	723	795
3250	BKH2	164	250	336	422	508	594	680	766	852	938
	BKH1 mini	147	169	200	240	290	349	418	495	583	680
	BKH1	155	189	234	289	354	429	514	609	714	829
3500	BKH2 mini	160	240	320	401	481	561	641	721	802	882
	BKH2	182	277	373	468	563	659	754	850	945	1041
	BKH1 mini	161	185	219	263	318	383	458	543	639	745
3750	BKH1	170	208	257	317	388	470	563	667	782	909
	BKH2 mini	176	264	352	440	528	616	704	792	880	969
	BKH2	199	304	409	514	619	724	829	934	1038	1143
4000	BKH1 mini	176	201	238	286	346	416	498	591	695	810
	BKH1	185	226	279	344	422	511	612	726	851	988
	BKH2 mini	192	288	384	480	576	672	767	863	959	1055
4250	BKH2	217	332	446	560	674	789	903	1017	1132	1246
	BKH1 mini	190	218	257	309	374	450	538	639	751	876
	BKH1	199	244	302	372	456	552	662	784	920	1068
4500	BKH2 mini	208	311	415	519	623	727	831	934	1038	1142
	BKH2	235	359	483	606	730	854	977	1101	1225	1348
	BKH1 mini	204	234	277	333	401	483	578	686	807	941
4750	BKH1	214	262	324	400	490	594	711	843	988	1148
	BKH2 mini	223	335	447	559	670	782	894	1006	1117	1229
	BKH2	253	386	519	652	785	919	1052	1185	1318	1451
5000	BKH1 mini	218	250	296	356	429	517	618	734	863	1007
	BKH1	229	281	347	428	524	635	761	901	1057	1227
	BKH2 mini	239	359	478	598	718	837	957	1077	1196	1316
4250	BKH2	271	414	556	699	841	983	1126	1268	1411	1553
	BKH1 mini	232	266	315	379	457	551	659	782	919	1072
	BKH1	244	299	369	456	558	676	810	960	1126	1307
4500	BKH2 mini	255	383	510	638	765	893	1020	1148	1275	1403
	BKH2	289	441	593	745	896	1048	1200	1352	1504	1656
	BKH1 mini	247	283	334	402	485	584	699	829	975	1137
4750	BKH1	259	317	392	484	592	717	859	1018	1194	1387
	BKH2 mini	271	406	542	677	812	948	1083	1219	1354	1489
	BKH2	307	468	629	791	952	1113	1275	1436	1597	1758
5000	BKH1 mini	261	299	354	425	513	618	739	877	1032	1203
	BKH1	274	335	414	511	626	759	909	1077	1263	1467
	BKH2 mini	287	430	573	717	860	1003	1146	1290	1433	1576
5000	BKH2	325	496	666	837	1008	1178	1349	1520	1690	1861
	BKH1 mini	275	315	373	448	541	651	779	925	1088	1268
	BKH1	289	354	437	539	660	800	958	1136	1332	1546
5000	BKH2 mini	302	454	605	756	907	1058	1210	1361	1512	1663
	BKH2	343	523	703	883	1063	1243	1423	1603	1783	1963

Values refer to a room temperature of $T_r = 20$ °C at a volume flow = 90 l/h. Measurements according to DIN 4704-4.

Correction factor for a room temperature T_r [°C] at a flow temperature $t_f = 60$ °C:

T_r [°C]	15	16	17	18	19	20	21	22	23	24
Factor	1.18	1.14	1.11	1.07	1.04	1.00	0.96	0.93	0.90	0.86

Example: BKH2, 4500 mm, $t_f = 60$ °C, $T_r = 23$ °C → $952 \text{ W} \times 0.90 = 856 \text{ W}$

6 DIMENSIONING AND LAYOUT

6.1 Dimensioning of the trench heating system

The dimensioning of the trench heating system depends on:

- The flow temperature
- The required output
- The possible installation length

Planning the maximum flow temperature t_v of the heating system is the key to a healthy warmth provided by the trench heating system. We recommend that the set-up temperature does not exceed 60 °C. Otherwise, the louvre temperature will be significantly below the dust carbonisation temperature, which can lead to unhealthy air. Best results are achieved with maximum flow temperatures of 50 to 55 °C.

Ideal case:

Optimum cold shielding is achieved when the trench heating system is installed along the entire glass surface (floor-touching glass surfaces such as in winter gardens or terrace doors).

Recommended maximum length of a heating circuit:

BKH1, BKH1 mini: 7.5 m (= 7.5 m heating element)

BKH2, BKH2 mini: 5.0 m (= 10 m heating element)

6.2 Delivery times

Despite tailored manufacture, the delivery lead time for the entire trench system with grids is only 5 to 7 working days (from the Leobersdorf factory). Exception: Grid with mitred tailoring 15 to 20 working days (from the Leobersdorf factory).

6.3 Mitres

90° floor trench mitres at the grid and pan can be provided at a surcharge.



6.4 Free accessibility

Due to the distances between the interior adjustment screws of ≤ 500 mm, the trench can be accessed without further measures being required. Loads up to 130 kg/m possible.

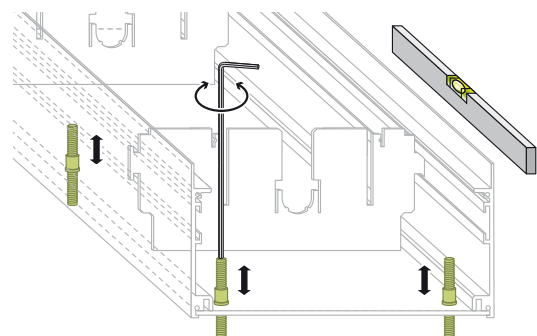

6.5 Air connection

A DN80 trench air connection for the BKH1/BKH2 can be implemented at a surcharge.

6.6 Installation examples

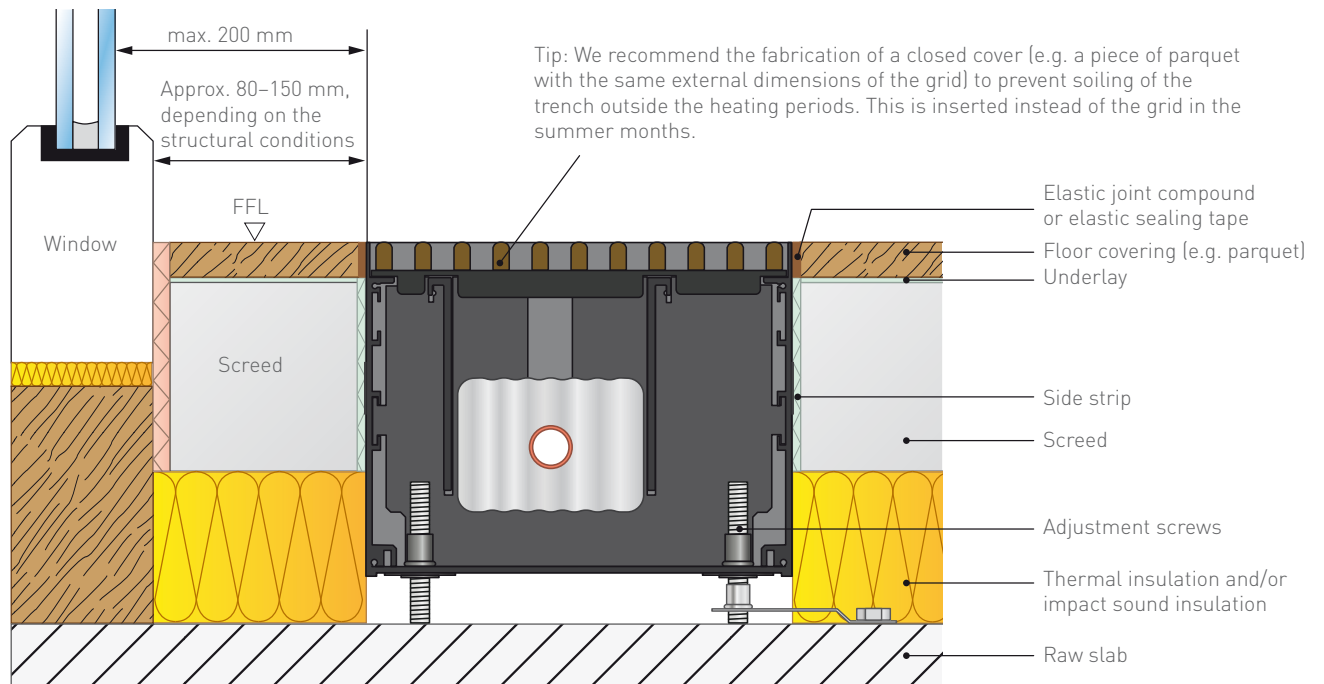

▲ Trench with clearance to window

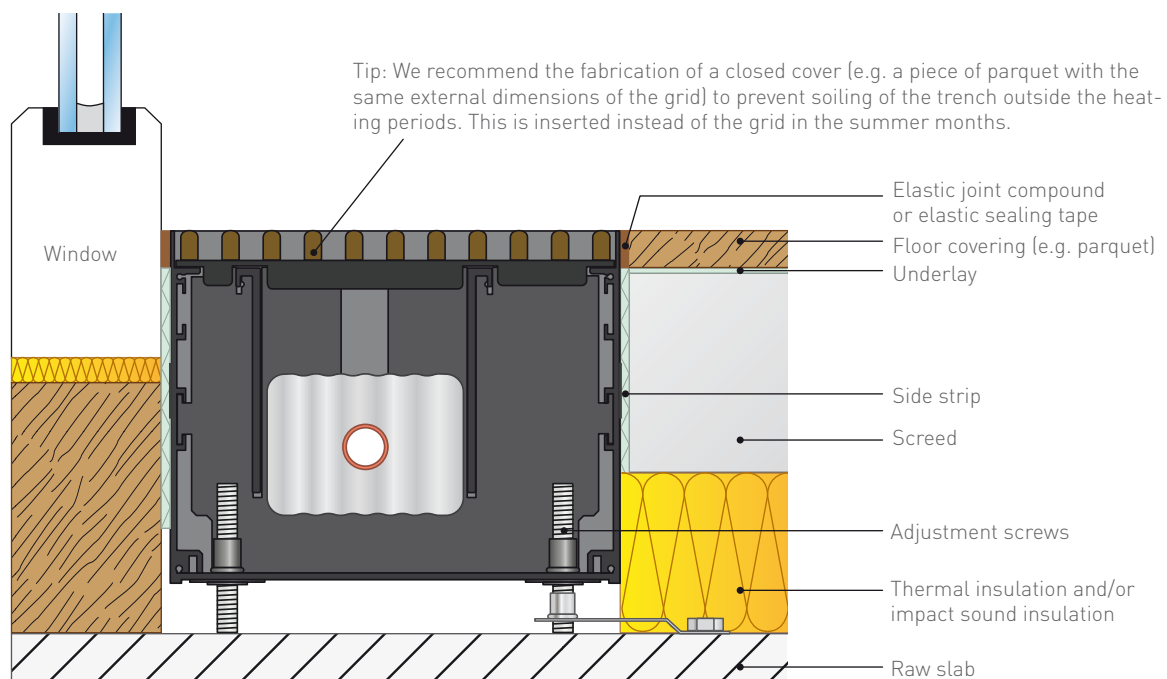

▲ Trench directly at the window

7 CONNECTION EXAMPLES

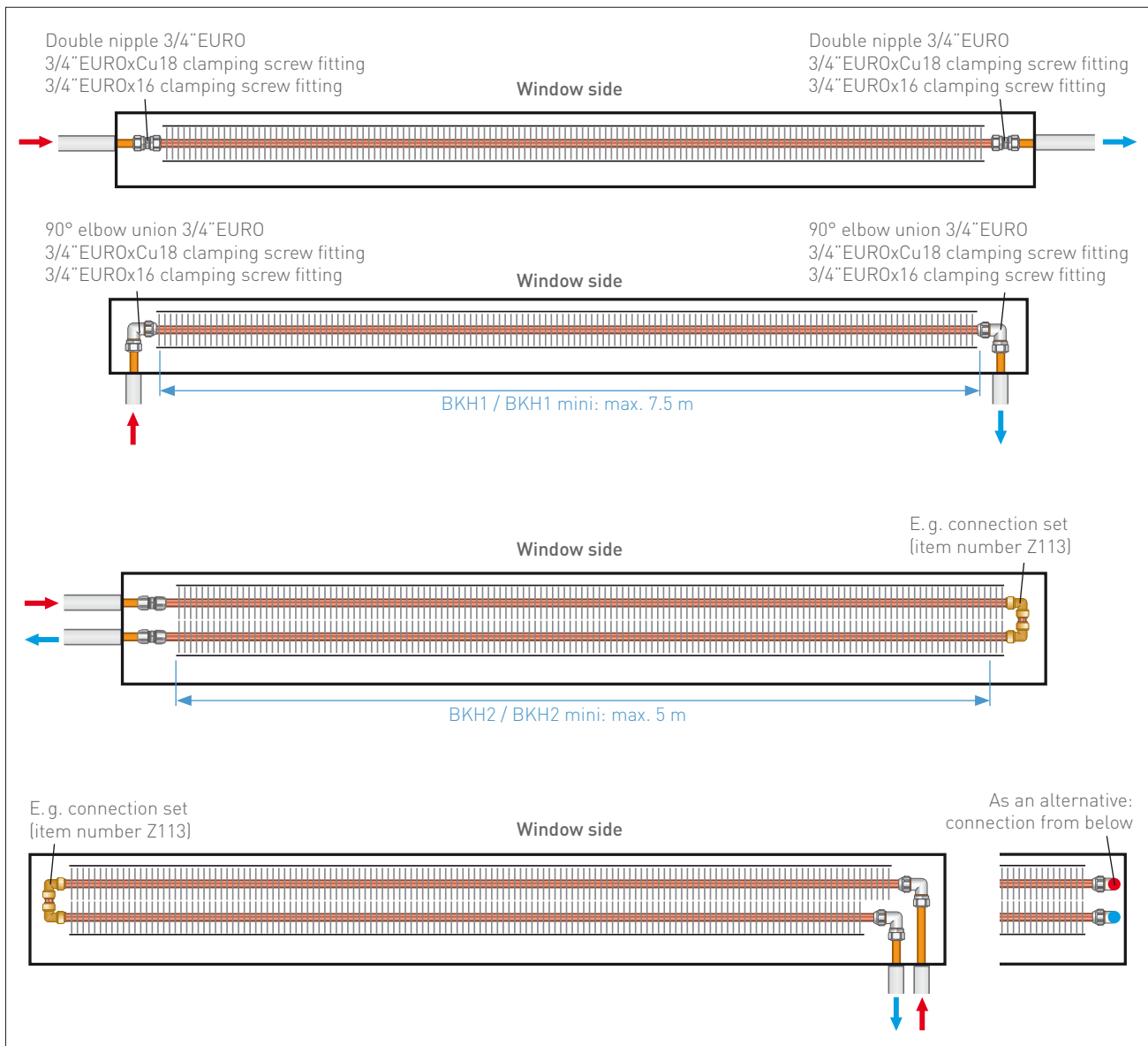

▲ Connection to a Variotherm heating distribution manifold using a pre-insulated 16x2 VarioModular pipe

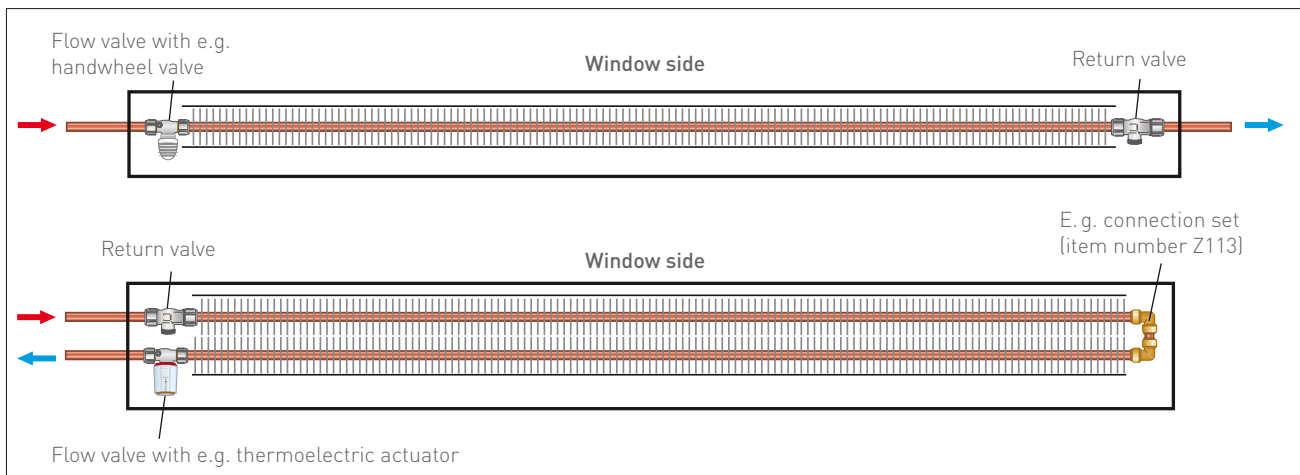

▲ Connection to a 2-pipe system

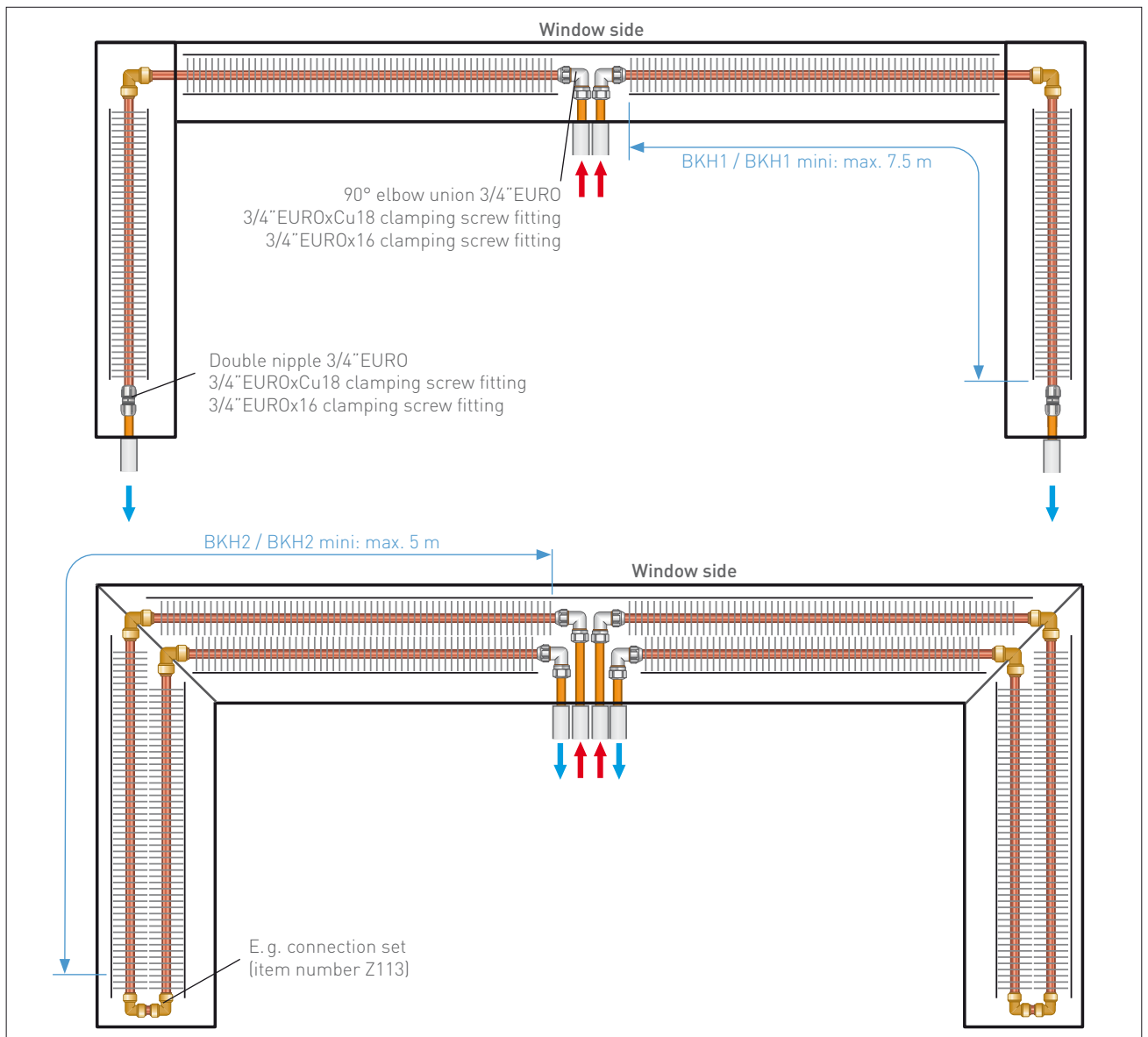

▲ Connection to a Variotherm heating distribution manifold using a pre-insulated 16x2 VarioModular pipe

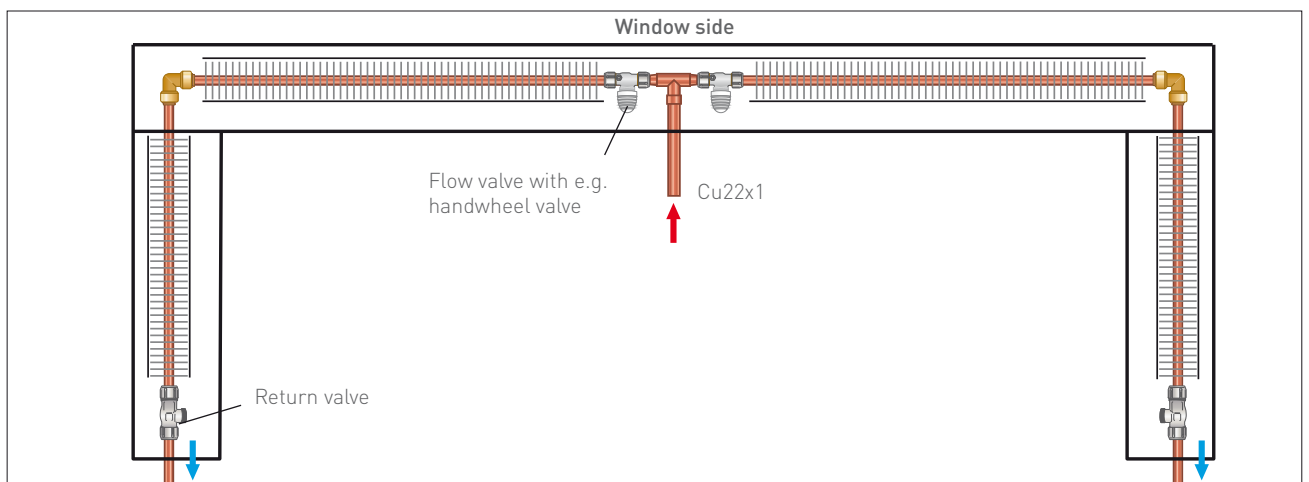

▲ Connection to a 2-pipe system

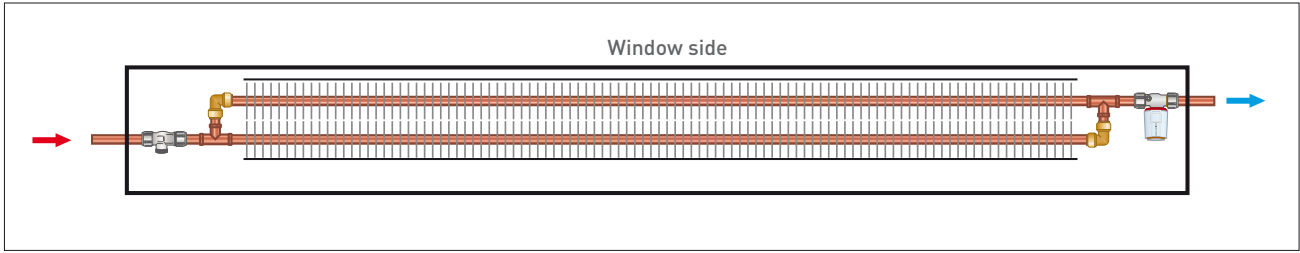

▲ BKH2/BKH2 mini, Connection left/right

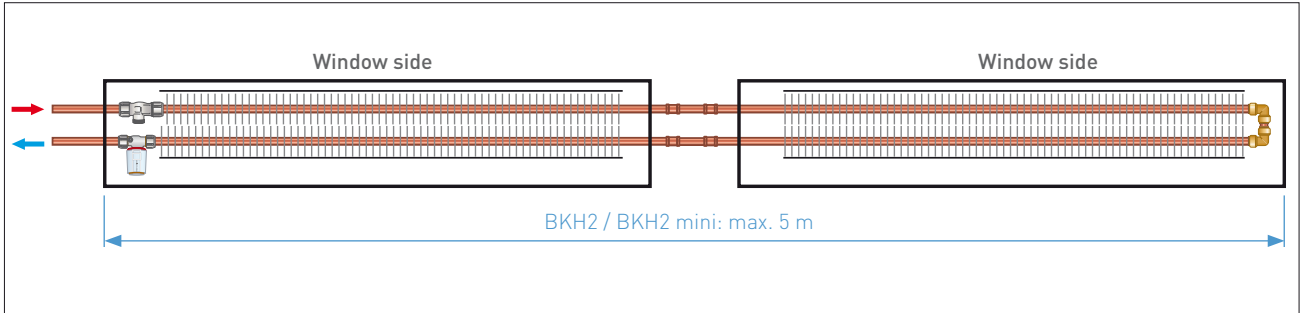

▲ BKH2/BKH2 mini, combined

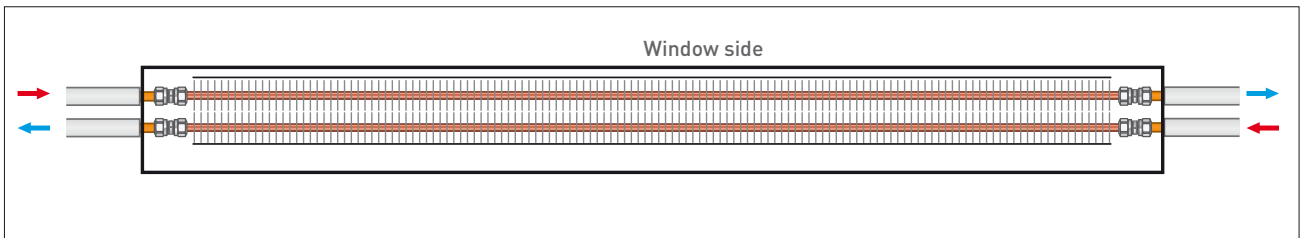

▲ BKH2/BKH2 mini, Length maximisation to 7.5 metres

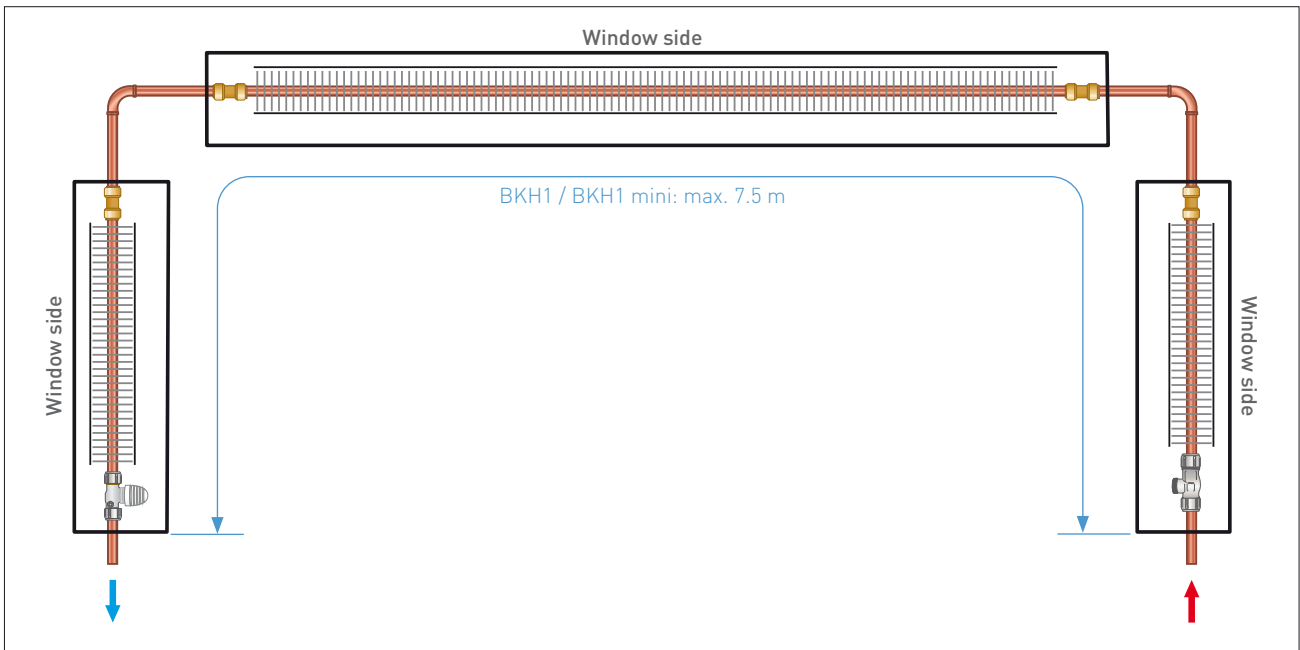

▲ BKH1/BKH1 mini, combined

ENJOY THE COMFORT & SAVE ENERGY

That's why our customers love us:

Heating and cooling optimised for COMFORT in all rooms!

Fast and friendly service, ANSWERS backed up with expertise!

Always in tune with the latest technology, INNOVATION guaranteed!

Everything CLEAR and SIMPLE, in writing of course!

PROFESSIONALISM at all times, from the first contact to the reference list!

VARIOTHERM SINCE 1979

Variotherm is an Austrian model plant with hundreds of partners in Austria, Europe and around the world.

All rights pertaining to distribution and translation, in whole or in part, including film, radio, television, video recording, Internet, photocopying and reprinting, are reserved. Subject to mistakes and printing errors. Misprints and errors excepted.



Austria's
Leading
Companies
2014



TH

VARIOTHERM HEIZSYSTEME GMBH

GÜNSELSDORFER STRASSE 3A

2544 LEOBERSDORF

AUSTRIA

Phone.: 0043 22 56 – 648 70-0

office@variotherm.com www.variotherm.com