

# FCZ

## Fan coil for universal and floor installation

Cooling capacity 0,65 ÷ 7,62 kW  
Heating capacity 1,45 ÷ 17,02 kW



- **Very quiet**
- **Touch controller mounted on-board. allows remote control with smart devices**



### DESCRIPTION

fan coil can be installed in any 2/4 pipe system and operates with any heat generator even at low temperatures, and thanks to varied versions and settings, it is easy to pick the ideal solution for any need.

### FEATURES

#### Case

Metallic micro-perforated cabinet with rustproofing polyester paint RAL 9003. Head with plastic air distribution grille RAL 7047.

**Depending on the version, the distribution grille may be adjustable.**

#### Ventilation group

Consisting of double suction centrifugal fans that are particularly silent, statically and dynamically balanced, and directly coupled with the motor shaft.

The motor is wired for single phase and has three speeds, with capacitor. The motor is fitted on sealed for life bearings and is secured on anti-vibration and self-lubricating mountings.

Extractable shrouds for easy, effective cleaning

#### Finned pack heat exchanger

With copper pipes and aluminium louvers, the standard or oversized heat exchanger and the possible secondary heat exchanger have female gas water connections on the left side and the manifolds have air vents.

The coil is not suitable for use in corrosive atmosphere or in environments where aluminium may be subject to corrosion.

**Reversibility of the water connections during installation only for units with a standard or boosted main heat exchanger, or standard with BV accessory. Not reversible in all other configurations. In any case, units with the coil water connections on the right are available at the time of ordering.**

#### Condensate drip

Provided standard in plastic and fixed to the interior structure; with external condensate discharge.

#### Air filter

Air filter class Coarse 25% for all versions easy to pull out and clean.

**In the APC version, air purification is guaranteed by the Cold Plasma purifier.**

The purifier is able to reduce pollutants, decomposing their molecules using electrical charges, causing the water molecules in the air to split into positive and negative ions. These ions neutralise the molecules in the gaseous pollutants, obtaining products normally present in clean air. The device is able to eliminate 90% of the bacteria. The result is clean, ionized air, free of foul odours.

### VERSIONS

**A** High, with fixed air distribution grille and built-in command

**ACT** High, with air distribution grille and electronic thermostat

**AF** High, without built-in command but with front intake

**APC** High, with air distribution grille, electronic thermostat and Cold Plasma purifier

**AS** High, with air distribution grille without built-in command

**U** Universal, with adjustable air distribution grille but without built-in thermostat

**UA** Universal, with fixed air distribution grille but without built-in thermostat

**UF** Universal, with adjustable air distribution grille but without built-in thermostat and with front intake grille

### Versions with fixed grille (high cabinet)

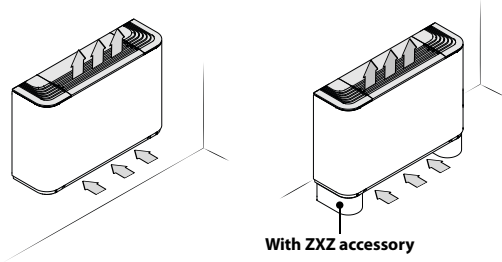

#### FCZ\_A

- With built-in selector.

#### FCZ\_AS

- Compatibility with VMF system.
- Without installed switch

#### FCZ\_ACT

- With electronic thermostat for 2-pipe systems only.

#### FCZ\_APC

- With electronic thermostat for 2-pipe systems only.
- Cold Plasma purifier

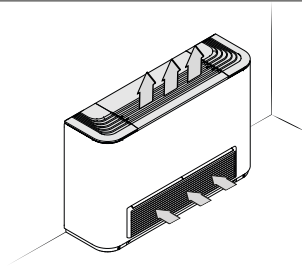

#### FCZ\_AF

- Without installed switch
- Compatibility with VMF system.
- Front intake grille.

### Versions with adjustable and fixed grille (universal)

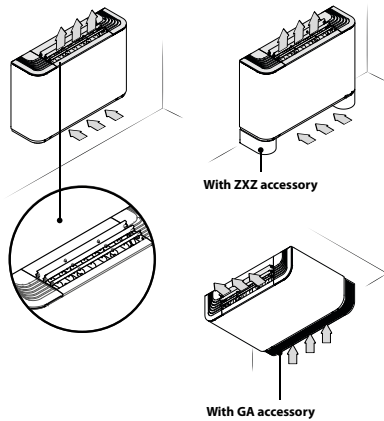

#### FCZ\_U

- Compatibility with VMF system.
- Without installed switch
- Distribution grille with adjustable louvers. Sizes 1, 2 and 3 have a single grille, whereas sizes 4, 5, 6, 7, 8, 9 and 10 have three grilles fully independent of each other. When all the fins have closed, the unit switches off.
- Vertical and horizontal installation for 2-pipe and 4-pipe systems.

#### FCZ\_UA

- Compatibility with VMF system.
- Without installed switch
- Air distribution grille with fixed louvers.
- Vertical and horizontal installation for 2-pipe and 4-pipe systems.

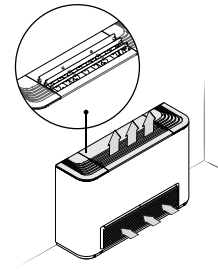

#### FCZ\_UF

- Compatibility with VMF system.
- Without installed switch
- Air delivery grille with adjustable louvers.
- Front intake grille.

### GUIDE TO SELECTING THE POSSIBLE CONFIGURATIONS

Field	Description
1,2,3	<b>FCZ</b>
4	<b>Size</b> 1, 2, 3, 4, 5, 6, 7, 8, 9, 10
5	<b>main heat exchanger</b>
0	Standard
5	Oversized
6	<b>Secondary heat exchanger</b>
0	Without exchanger
1	Standard
2	Oversized (on request only)
7	<b>Version</b>
	<b>Only vertical installation.</b>
A	High, with fixed air distribution grille and built-in command
ACT	High, with air distribution grille and electronic thermostat
AF	High, without built-in command but with front intake
APC	High, with air distribution grille, electronic thermostat and Cold Plasma purifier
AS	Free standing without installed switch
	<b>Vertical and horizontal installation.</b>
U	Universal, with adjustable air distribution grille but without built-in thermostat
UA	Universal, with fixed air distribution grille but without built-in thermostat
UF	Universal, with adjustable air distribution grille but without built-in thermostat and with front intake grille

## SIZE AVAILABLE FOR VERSION

Size	100	101	102	150	200	201	202	250	300	301	302	350	400	401	402	450	500	501	502	550
Versions produced (by size)																				
Versions available (by size)	A,AS,U,UA	.	.	.	.	.	.	.	.	.	.	.	.	.	.	.	.	.	.	.
	ACT,APC	.	.	.	.	.	.	.	.	.	.	.	.	.	.	.	.	.	.	.
	AF,UF	.	.	.	.	.	.	.	.	.	.	.	.	.	.	.	.	.	.	.

Size	600	601	602	650	700	701	702	750	800	801	802	850	900	901	950	1000	1001
Versions produced (by size)																	
Versions available (by size)	A,AS,U,UA	.	.	.	.	.	.	.	.	.	.	.	.	.	.	.	.
	ACT,APC	.	.	.	.	.	.	.	.	.	.	.	.	.	.	.	.
	AF,UF	.	.	.	.	.	.	.	.	.	.	.	.	.	.	.	.

## ACCESSORIES

### Control panels

**AER503IR:** Flush-mounting thermostat with backlit display, capacitive keypad and infrared receiver, for controlling both brushless fan coils and those with an asynchronous motor. In 2-pipe systems, the thermostat can control standard fan coils or those equipped with an electric heater, with air purifying devices (Cold Plasma and germicidal lamp), with radiant plate or with FCZ-D twin delivery (Dualjet). In addition, it can control systems with radiant panels or mixed (fan coil and radiant floor) systems. Being equipped with an infrared receiver, it can, in turn, be controlled by the VMF-IR remote control.

**DSKT:** Thermostat with an easy-to-read light display that provides clear information on room temperature, programming settings and more. Thanks to the ergonomic ring nut switch, adjusting the desired temperature is very easy. The knob allows precise and immediate adjustments, offering a classic but highly effective control mode. Not only functional, but also aesthetically pleasing. Our thermostat features a modern, compact design that fits perfectly in any environment, adding a touch of style to your home or office.

**PX2Z:** On-board electromechanical switch.

**SA5:** air probe kit (L = 15 m) with probe-locking cable grommet.

**SIT3:** Thermostat Interface Card allowing the creation of a network of fan coils (max. 10) commanded by a central control panel (selector or thermostat). Commands the 3 fan speeds and must be installed on each fan coil within the network; receives the commands from the selector or the SIT5 card. In case you decide to install Aermec thermostats and current absorbed by the unit exceeds 0.7 A, you're obliged to include SIT3 accessory.

**SIT5:** Thermostat Interface Card allowing the creation of a network of fan coils (max. 10) commanded by a central control panel. Commands the 3 fan speeds and up to 2 valves (four pipe systems); sends the thermostat's commands to the fan coil network.

**SW3:** Water probe (L = 2.5 m) for controlling the minimum and maximum and to allow automatic seasonal switching for electronic thermostats fitted with water side changeover.

**SW5:** water probe kit (L = 15m) with probe-holder connection point, fixing clip and probe-holder from heat exchanger.

**T-TOUCH:** Touch control on board the machine, for controlling fan coils with asynchronous motors. In 2-pipe systems, it can control standard fan coils or those equipped with an electric heater, with air purifying devices or with FCZ-D twin delivery (Dualjet). In 4-pipe systems, only standard fan coils.

**TX:** Wall-mounting thermostat for controlling either brushless fan coils or those with asynchronous motors for 2/4 pipe. In 2-pipe systems, the thermostat can control standard fan coils or those equipped with an electric heater, with air purifying devices, radiant plate or FCZ-D twin delivery (Dualjet).

**TXB:** Wall-mounting thermostat for controlling either brushless fan coils or those with asynchronous motors for 2/4 pipe. In 2-pipe systems, the thermostat can control standard fan coils or those equipped with an electric heater, with air purifying devices, radiant plate or FCZ-D twin delivery (Dualjet).

**WMT10:** Electronic thermostat, white, with thermostated or continuous ventilation.

**WMT16:** Electronic thermostat with thermostated ventilation.

**WMT16CV:** Electronic thermostat with continuous ventilation.

### AerSuite

The AerSuite application is used to remotely control the DI24 user interface, with VMF-E19/VMF-E19I thermostats, using Smart Devices with iOS and Android operating systems.

This is an application for Smartphones and Tablets with which the user can access and control the system operation remotely.

For more information about the use of the application and the available functions, refer to the respective documentation on the website.



### VMF system

**DI24:** Flush-mounted interface (503 box) with 2.4" touch screen display to be combined with VMF-E19, VMF-E19I accessories. It allows you to regulate and monitor the temperature inside rooms precisely and on time; in addition to accessing and interacting with your system's operating information, parameters and alarms, it allows you to set time slots. Thanks to its Wi-Fi connection, DI24 in combination with the AerSuite APP (available for Android and iOS) can also be remotely controlled. All programming and most functions are done in a simple and intuitive way using the APP. To allow for customization of the interface so that it seamlessly integrates with the style of any home, DI24 is compatible with switch plates from major brands available on the market. For more information, please refer to our documentation. However, a switch plate with its graphite gray support, DI24CP, is also available as a separate accessory in our catalog.

**VMF-E19:** Thermostat to be secured to the side of the fan coil, fitted as standard with an air probe and a water probe.

**VMF-E2Z:** User interface on the machine, to be combined with the VMF-E19 and VMF-E19I accessory.

**VMF-E3:** Wall mounted user interface, to be combined with accessories VMF-E19, VMF-E19I, with grids GLF\_N/M and GLL\_N, can be controlled with VMF-IR control.

**VMF-E4DX:** Wall-mounted user interface. Grey front panel PANTONE 425C (METAL).

**VMF-E4X:** Wall-mounted user interface. Light grey front panel PANTONE COOL GRAY 1C.

**VMF-IR:** User interface compatible with the AER503IR, VMF-E3 thermostat and with all the grids of cassettes equipped with the infrared receiver compatible with the VMF system.

**VMF-SW:** Water probe (L = 2.5m) used if required in place of the standard unit supplied with the VMF-E19 and VMF-E19I thermostats for mounting it upstream of the valve.

**VMF-SW1:** Additional water probe (L = 2.5m) to be used if required for 4-pipe systems with the VMF-E19 and VMF-E19I thermostats for maximum control in the cold range

**VMHI:** The VMHI panel can be used as a user interface for VMF-E19/E19I thermostats, GLFxN/M or GLLxN grids, or as an interface for the MZC system. What determines the function to be performed by the user interface is determined by its correct parametrisation and by following the electrical connections between interface and thermostat or interface and plenum.

### Water valves

**VCZ\_X:** 3-way valve kit for single-coil fan coil, RH connections, (VCZ\_X4R) or LH (VCZ\_X4L) for 4-pipe systems. With totally separate "heating" and "cooling" circuits. This kit consists of two 3-way insulated valves and four connections, complete with electrothermal actuators, insulating shells for the valves, and the relative hydraulic couplings. X4L version for fan coils

with LH connections, and X4R for fan coils with RH connections. 230V~50Hz power supply.

**VZ:** 3-way motorised valve kit for the main coil. The kit is made up of a valve with its insulating shell, actuator and relative hydraulic fittings. It can be installed on fan coils with both right and left connections. If the valve is combined with the BCZ5 or BCZ6 condensate drain pan, to ensure a better housing it is possible to remove the insulating shell.

**VCF44 - 45 - for secondary heat exchanger:** The 3-way motorised valve kit for the secondary coil heat only. The kit consists of a valve with its insulating shell, actuator and relevant water fittings; it is suitable to be installed on the fan coils with right and left water connections.

**VZD:** 2-way motorised valve kit. The kit consists of a valve, an actuator and the relative pipe fittings. It can be installed on fan coils with both right and left connections.

**VJP:** Control and balancing combination valve for 2 and 4 pipe systems to install outside the unit, supplied without fittings and hydraulic components.

The valve, which can guarantee a constant water flow rate in the terminal, within its operating range.

**(Heating only) additional coil**

**BV:** Hot water heat exchanger with 1 row.

**RX:** Armoured electric coil with safety thermostat.

**Installation accessories**

**PCZ:** Metal panel for the unit rear closing. SPCZ brackets are necessary to fix floor standing fan coils.

**GA:** Lower intake grille for encapsulated fan coils. Can also be used in wall-mounted or floor installations, the FIKIT accessory is needed only in the case of floor installation.

**FIKIT:** Structural bracket in floor installation.

**DSCZ4:** Condensate drainage device.

**BCZ:** Condensate drip. If the valve is paired with the BCZ5 or BCZ6 condensate drip tray, the insulating shell can be removed to ensure better housing.

**AMP:** Wall mounting kit

**ACCESSORIES COMPATIBILITY**

**Control panels**

Model	Ver	100	101	102	150	200	201	202	250
AERS03IR (1)	AF,UF	*			*	*			*
	AS,U,UA	*	*	*	*	*	*	*	*
DSKT	AS	*	*	*	*	*	*	*	*
	AF,UF	*			*	*			*
PX2Z	AS,U	*	*	*	*	*	*	*	*
	AF,UF	*			*	*			*
SA5 (2)	AS,U,UA	*	*	*	*	*	*	*	*
	AF,UF	*			*	*			*
SIT3 (3)	AS,U,UA	*	*	*	*	*	*	*	*
	AF,UF	*			*	*			*
SIT5 (4)	AS,U,UA	*	*	*	*	*	*	*	*
	AF,AS,UF	*			*	*			*
SW3 (2)	U,UA	*	*	*	*	*	*	*	*
	AF,UF	*			*	*			*
SWS (2)	AS,U,UA	*	*	*	*	*	*	*	*
	AF,UF	*			*	*			*
T-TOUCH (5)	AF,UF	*			*	*			*
	AS,U	*	*	*	*	*	*	*	*
TX (6)	AF,UF	*			*	*			*
	AS,U,UA	*	*	*	*	*	*	*	*
TXB (5)	AF,UF	*			*	*			*
	AS,U,UA	*	*	*	*	*	*	*	*
WMT10 (6)	AF,UF	*			*	*			*
	AS,U,UA	*	*	*	*	*	*	*	*
WMT16 (6)	AF,AS,U,UA,UF	*			*	*			*
	AF,UF	*			*	*			*
WMT16CV (6)	AS,U	*	*	*	*	*	*	*	*
	AF,UF	*			*	*			*

Model	Ver	300	301	302	350	400	401	402	450
AERS03IR (1)	AF,UF	*			*	*			*
	AS,U,UA	*	*	*	*	*	*	*	*
DSKT	AS	*	*	*	*	*	*	*	*
	AF,UF	*			*	*			*
PX2Z	AS,U	*	*	*	*	*	*	*	*
	AF,UF	*			*	*			*
SA5 (2)	AS,U,UA	*	*	*	*	*	*	*	*
	AF,UF	*			*	*			*
SIT3 (3)	AS,U,UA	*	*	*	*	*	*	*	*
	AF,UF	*			*	*			*
SIT5 (4)	AS,U,UA	*	*	*	*	*	*	*	*
	AF,AS,UF	*			*	*			*
SW3 (2)	U,UA	*	*	*	*	*	*	*	*
	AF,UF	*			*	*			*
SWS (2)	AS,U,UA	*	*	*	*	*	*	*	*
	AF,UF	*			*	*			*
T-TOUCH (5)	AF,UF	*			*	*			*
	AS,U	*	*	*	*	*	*	*	*
TX (6)	AF,UF	*			*	*			*
	AS,U,UA	*	*	*	*	*	*	*	*
TXB (5)	AF,UF	*			*	*			*
	AS,U,UA	*	*	*	*	*	*	*	*
WMT10 (6)	AF,UF	*			*	*			*
	AS,U,UA	*	*	*	*	*	*	*	*
WMT16 (6)	AF,AS,U,UA,UF	*			*	*			*
	AF,UF	*			*	*			*
WMT16CV (6)	AS,U	*	*	*	*	*	*	*	*
	AF,UF	*			*	*			*

Model	Ver	500	501	502	550	600	601	602	650
AERS03IR (1)	AF,UF	*			*				
	AS,U,UA	*	*	*	*	*	*	*	*
DSKT	AS	*	*	*	*	*	*	*	*
PX2Z	AF,UF	*			*				
	AS,U	*	*	*	*	*	*	*	*
SA5 (2)	AF,UF	*			*				
	AS,U,UA	*	*	*	*	*	*	*	*
SIT3 (3)	AS,U,UA	*	*	*	*	*	*	*	*
SIT5 (4)	AS,U,UA	*	*	*	*	*	*	*	*
SW3 (2)	AF,UF	*			*				
	AS	*			*	*	*	*	*
	U,UA	*	*	*	*	*	*	*	*
SWS (2)	AF,UF	*			*				
	AS,U,UA	*	*	*	*	*	*	*	*
T-TOUCH (5)	AF,UF	*			*				
	AS,U	*	*	*	*	*	*	*	*
TX (6)	AF,UF	*			*				
	AS,U,UA	*	*	*	*	*	*	*	*
TXB (5)	AF,UF	*			*				
	AS,U,UA	*	*	*	*	*	*	*	*
WMT10 (6)	AF,UF	*			*				
	AS,U,UA	*	*	*	*	*	*	*	*
WMT16 (6)	AF,UF	*			*				
	AS,U,UA	*	*	*	*	*	*	*	*
WMT16CV (6)	AF,UF	*			*				
	AS,U	*	*	*	*	*	*	*	*

Model	Ver	700	701	702	750	800	801	802	850
AERS03IR (1)	AS,U,UA	*	*	*	*	*	*	*	*
DSKT	AS	*	*	*	*	*	*	*	*
PX2Z	AS,U	*	*	*	*	*	*	*	*
SA5 (2)	AS,U,UA	*	*	*	*	*	*	*	*
SIT3 (3)	AS,U,UA	*	*	*	*	*	*	*	*
SIT5 (4)	AS,U,UA	*	*	*	*	*	*	*	*
SW3 (2)	AS,U,UA	*	*	*	*	*	*	*	*
SWS (2)	AS,U,UA	*	*	*	*	*	*	*	*
T-TOUCH (5)	AS,U	*	*	*	*	*	*	*	*
TX (6)	AS,U,UA	*	*	*	*	*	*	*	*
TXB (5)	AS,U,UA	*	*	*	*	*	*	*	*
WMT10 (6)	AS,U,UA	*	*	*	*	*	*	*	*
WMT16 (6)	AS,U,UA	*	*	*	*	*	*	*	*
WMT16CV (6)	AS,U	*	*	*	*	*	*	*	*

Model	Ver	900	901	950	1000	1001
AERS03IR (1)	AF,UF			*	*	
	AS,U,UA	*	*	*	*	*
DSKT	AS	*	*	*	*	*
PX2Z	AF,UF	*	*	*	*	*
	AS,U	*	*	*	*	*
SA5 (2)	AF,UF	*	*	*	*	*
	AS,U,UA	*	*	*	*	*
SIT3 (3)	AF,UF	*	*	*	*	*
	AS,U,UA	*	*	*	*	*
SIT5 (4)	AF,UF	*	*	*	*	*
	AS,U,UA	*	*	*	*	*
SW3 (2)	AF,UF	*	*	*	*	*
	AS	*	*	*	*	*
	U,UA	*	*	*	*	*
SWS (2)	AF,UF	*	*	*	*	*
	AS,U,UA	*	*	*	*	*
T-TOUCH (5)	AF,UF	*	*	*	*	*
	AS,U	*	*	*	*	*
TX (6)	AF,UF	*	*	*	*	*
	AS,U,UA	*	*	*	*	*
TXB (5)	AF,UF	*	*	*	*	*
	AS,U,UA	*	*	*	*	*
WMT10 (6)	AF,UF	*	*	*	*	*
	AS,U,UA	*	*	*	*	*
WMT16 (6)	AF,AS,U,UA,UF	*	*	*	*	*

Model	Ver	900	901	950	1000	1001
WMT16CV (6)	AF,UF	*		*	*	
	AS,U	*	*	*	*	*

- (1) Wall-mount installation.
- (2) Probe for AERS03IR-TX thermostats, if fitted.
- (3) Cards for AERS03IR-TX thermostats, if present, to be installed if the unit absorption exceeds 0,7 Ampere.
- (4) Probe for AERS03IR-TX thermostats, if fitted.
- (5) Installation on the fan coil.
- (6) Wall-mounting. If the unit intake exceeds 0.7A, or several units need to be managed with a single thermostat, board SIT3 and/or SIT5 is required.

### VMF system

For more information about VMF system, refer to the dedicated documentation.

#### VMF system

Model	Ver	100	101	102	150	200	201	202	250	300	301
DI24	AF,AS,U,UA,UF	*			*	*			*	*	
	AF,UF	*			*	*			*	*	
VMF-E19 (1)	AS,U,UA	*	*	*	*	*	*	*	*	*	*
	AF,UF	*			*	*			*	*	
VMF-E2Z	AS,U,UA	*	*	*	*	*	*	*	*	*	*
	AF,UF	*			*	*			*	*	
VMF-E3	U,UA	*	*	*	*	*	*	*	*	*	*
	AF,UF	*			*	*			*	*	
VMF-E4DX	AS,U,UA	*	*	*	*	*	*	*	*	*	*
	AF,UF	*			*	*			*	*	
VMF-E4X	AS,U,UA	*	*	*	*	*	*	*	*	*	*
	AF,UF	*			*	*			*	*	
VMF-IR	U,UA	*	*	*	*	*	*	*	*	*	*
	AF,UF	*			*	*			*	*	
VMF-SW	AS,U	*	*	*	*	*	*	*	*	*	*
	AF,UF	*			*	*			*	*	
VMF-SW1	AS,U	*	*	*	*	*	*	*	*	*	*
	AF,UF	*			*	*			*	*	
VMHI	AS,U,UA	*	*	*	*	*	*	*	*	*	*
	AF,UF	*			*	*			*	*	

Model	Ver	302	350	400	401	402	450	500	501	502	550
DI24	AF,AS,U,UA,UF	*	*	*	*	*	*	*	*	*	*
	AF,UF	*	*	*	*	*	*	*	*	*	*
VMF-E19 (1)	AS,U,UA	*	*	*	*	*	*	*	*	*	*
	AF,UF	*	*	*	*	*	*	*	*	*	*
VMF-E2Z	AS,U,UA	*	*	*	*	*	*	*	*	*	*
	AF,UF	*	*	*	*	*	*	*	*	*	*
VMF-E3	U,UA	*	*	*	*	*	*	*	*	*	*
	AF,UF	*	*	*	*	*	*	*	*	*	*
VMF-E4DX	AS,U,UA	*	*	*	*	*	*	*	*	*	*
	AF,UF	*	*	*	*	*	*	*	*	*	*
VMF-E4X	AS,U,UA	*	*	*	*	*	*	*	*	*	*
	AF,UF	*	*	*	*	*	*	*	*	*	*
VMF-IR	U,UA	*	*	*	*	*	*	*	*	*	*
	AF,UF	*	*	*	*	*	*	*	*	*	*
VMF-SW	AS,U	*	*	*	*	*	*	*	*	*	*
	AF,UF	*	*	*	*	*	*	*	*	*	*
VMF-SW1	AS,U	*	*	*	*	*	*	*	*	*	*
	AF,UF	*	*	*	*	*	*	*	*	*	*
VMHI	AS,U,UA	*	*	*	*	*	*	*	*	*	*
	AF,UF	*	*	*	*	*	*	*	*	*	*

Model	Ver	600	601	602	650	700	701	702	750	800	801
DI24	AS,UA	*	*	*	*	*	*	*	*	*	*
	U	*	*	*	*	*	*	*	*	*	*
VMF-E19 (1)	AS,UA	*	*	*	*	*	*	*	*	*	*
	U	*	*	*	*	*	*	*	*	*	*
VMF-E2Z	AS,UA	*	*	*	*	*	*	*	*	*	*
	U	*	*	*	*	*	*	*	*	*	*
VMF-E3	AF,UF	*	*	*	*	*	*	*	*	*	*
	U,UA	*	*	*	*	*	*	*	*	*	*
VMF-E4DX	AS,UA	*	*	*	*	*	*	*	*	*	*
	U	*	*	*	*	*	*	*	*	*	*
VMF-E4X	AS,UA	*	*	*	*	*	*	*	*	*	*
	U	*	*	*	*	*	*	*	*	*	*
VMF-IR	AF,UF	*	*	*	*	*	*	*	*	*	*
	U,UA	*	*	*	*	*	*	*	*	*	*
VMF-SW	AS	*	*	*	*	*	*	*	*	*	*
	U	*	*	*	*	*	*	*	*	*	*
VMF-SW1	AS	*	*	*	*	*	*	*	*	*	*
	U	*	*	*	*	*	*	*	*	*	*

Model	Ver	600	601	602	650	700	701	702	750	800	801
VMHI	AS,UA	.	.	.	.	.	.	.	.	.	.
	U	.	.	.	.	.	.	.	.	.	.
Model	Ver	802	850	900	901	950	1000	1001			
DI24	AF,AS,U,UA,UF	.	.	.	.	.	.	.			
	AF,UF	.	.	.	.	.	.	.			
VMF-E19 (1)	AS,UA	.	.	.	.	.	.	.			
	U	.	.	.	.	.	.	.			
VMF-E2Z	AF,UF	.	.	.	.	.	.	.			
	AS,UA	.	.	.	.	.	.	.			
VMF-E3	AF	.	.	.	.	.	.	.			
	U,UA	.	.	.	.	.	.	.			
VMF-E4DX	UF	.	.	.	.	.	.	.			
	AF,UF	.	.	.	.	.	.	.			
VMF-E4X	AS,UA	.	.	.	.	.	.	.			
	U	.	.	.	.	.	.	.			
VMF-IR	AF	.	.	.	.	.	.	.			
	U,UA	.	.	.	.	.	.	.			
VMF-SW	UF	.	.	.	.	.	.	.			
	AF,UF	.	.	.	.	.	.	.			
VMF-SW1	AS	.	.	.	.	.	.	.			
	U	.	.	.	.	.	.	.			
VMHI	AF,UF	.	.	.	.	.	.	.			
	AS,UA	.	.	.	.	.	.	.			
	U	.	.	.	.	.	.	.			

(1) Also the accessory VMF-SIT3V is mandatory if the unit exceeds 0.7 Amperes.

## Water valves

### 3 way valve kit

	100	101	102	150	200	201	202	250	300	301	302	350	400	401	402	450
<b>Main coil</b>	VCZ41	VCZ41	VCZ41	VCZ41	VCZ41	VCZ41	VCZ41	VCZ41	VCZ42	VCZ42	VCZ42	VCZ42	VCZ42	VCZ42	VCZ42	VCZ42
	VCZ4124	VCZ4124	VCZ4124	VCZ4124	VCZ4124	VCZ4124	VCZ4124	VCZ4124	VCZ4224	VCZ4224	VCZ4224	VCZ4224	VCZ4224	VCZ4224	VCZ4224	VCZ4224
<b>Secondary coil</b>	-	VCF44	VCF44	-	-	VCF44	VCF44	-	-	VCF44	VCF44	-	-	VCF44	VCF44	-
	-	VCF4424	VCF4424	-	-	VCF4424	VCF4424	-	-	VCF4424	VCF4424	-	-	VCF4424	VCF4424	-
<b>Additional coil "BV"</b>	VCF44	-	-	-	VCF44	-	-	-	VCF44	-	-	-	VCF44	-	-	-
	VCF4424	-	-	-	VCF4424	-	-	-	VCF4424	-	-	-	VCF4424	-	-	-
	500	501	502	550	600	601	602	650	700	701	702	750	800	801	802	850
<b>Main coil</b>	VCZ42	VCZ42	VCZ42	VCZ42	VCZ42	VCZ42	VCZ42	VCZ42	VCZ42	VCZ42	VCZ42	VCZ42	VCZ42	VCZ42	VCZ42	VCZ42
	VCZ4224	VCZ4224	VCZ4224	VCZ4224	VCZ4224	VCZ4224	VCZ4224	VCZ4224	VCZ4224	VCZ4224	VCZ4224	VCZ4224	VCZ4224	VCZ4224	VCZ4224	VCZ4224
<b>Secondary coil</b>	-	VCF44	VCF44	-	-	VCF44	VCF44	-	-	VCF44	VCF44	-	-	VCF44	VCF44	-
	-	VCF4424	VCF4424	-	-	VCF4424	VCF4424	-	-	VCF4424	VCF4424	-	-	VCF4424	VCF4424	-
<b>Additional coil "BV"</b>	VCF44	-	-	-	VCF44	-	-	-	VCF44	-	-	-	VCF44	-	-	-
	VCF4424	-	-	-	VCF4424	-	-	-	VCF4424	-	-	-	VCF4424	-	-	-
	900	901	950	1000	1001											
<b>Main coil</b>	VCZ43	VCZ43	VCZ43	VCZ43	VCZ43											
	VCZ4324	VCZ4324	VCZ4324	VCZ4324	VCZ4324											
<b>Secondary coil</b>	-	VCF45	-	-	VCF45											
	-	VCF4524	-	-	VCF4524											
<b>Additional coil "BV"</b>	VCF45	-	-	VCF45	-											
	VCF4524	-	-	VCF4524	-											

### 2 way valve kit

	100	101	102	150	200	201	202	250	300	301	302	350	400	401	402	450
<b>Main coil</b>	VCZD1	VCZD1	VCZD1	VCZD1	VCZD1	VCZD1	VCZD1	VCZD1	VCZD2	VCZD2	VCZD2	VCZD2	VCZD2	VCZD2	VCZD2	VCZD2
	VCZD124	VCZD124	VCZD124	VCZD124	VCZD124	VCZD124	VCZD124	VCZD124	VCZD224	VCZD224	VCZD224	VCZD224	VCZD224	VCZD224	VCZD224	VCZD224
<b>Secondary coil</b>	-	VCFD4	VCFD4	-	-	VCFD4	VCFD4	-	-	VCFD4	VCFD4	-	-	VCFD4	VCFD4	-
	-	VCFD424	VCFD424	-	-	VCFD424	VCFD424	-	-	VCFD424	VCFD424	-	-	VCFD424	VCFD424	-
<b>Additional coil "BV"</b>	VCFD4	-	-	-	VCFD4	-	-	-	VCFD4	-	-	-	VCFD4	-	-	-
	VCFD424	-	-	-	VCFD424	-	-	-	VCFD424	-	-	-	VCFD424	-	-	-
	500	501	502	550	600	601	602	650	700	701	702	750	800	801	802	850
<b>Main coil</b>	VCZD2	VCZD2	VCZD2	VCZD2	VCZD2	VCZD2	VCZD2	VCZD2	VCZD2	VCZD2	VCZD2	VCZD2	VCZD2	VCZD2	VCZD2	VCZD2
	VCZD224	VCZD224	VCZD224	VCZD224	VCZD224	VCZD224	VCZD224	VCZD224	VCZD224	VCZD224	VCZD224	VCZD224	VCZD224	VCZD224	VCZD224	VCZD224

	100	101	102	150	200	201	202	250	300	301	302	350	400	401	402	450
<b>Secondary coil</b>	-	VCFD4 VCFD424	VCFD4 VCFD424	-	-	VCFD4 VCFD424	VCFD4 VCFD424	-	-	VCFD4 VCFD424	VCFD4 VCFD424	-	-	VCFD4 VCFD424	VCFD4 VCFD424	-
<b>Additional coil "BV"</b>	VCFD4 VCFD424	-	-	-	VCFD4 VCFD424	-	-	-	VCFD4 VCFD424	-	-	-	VCFD4 VCFD424	-	-	-

	900	901	950	1000	1001
<b>Main coil</b>	VCZD3 VCZD324	VCZD3 VCZD324	VCZD3 VCZD324	VCZD3 VCZD324	VCZD3 VCZD324
<b>Secondary coil</b>	-	VCFD4 VCFD424	-	-	VCFD4 VCFD424
<b>Additional coil "BV"</b>	VCFD4 VCFD424	-	-	VCFD4 VCFD424	-

**Valve Kit for 4 pipe systems - Requires a thermostat with valve management**

Model	Ver	100	101	102	150	200	201	202	250
VCZ1X4L (1)	AF,AS,U,UA,UF	.	.	.	.	.	.	.	.
VCZ1X4R (1)	AF,AS,U,UA,UF	.	.	.	.	.	.	.	.

Model	Ver	300	301	302	350	400	401	402	450
VCZ2X4L (1)	AF,AS,U,UA,UF	.	.	.	.	.	.	.	.
VCZ2X4R (1)	AF,AS,U,UA,UF	.	.	.	.	.	.	.	.

Model	Ver	500	501	502	550	600	601	602	650
VCZ2X4L (1)	AF,UF	.	.	.	.	.	.	.	.
	AS,U,UA	.	.	.	.	.	.	.	.
VCZ2X4R (1)	AF,UF	.	.	.	.	.	.	.	.
	AS,U,UA	.	.	.	.	.	.	.	.

Model	Ver	700	701	702	750	800	801	802	850
VCZ2X4L (1)	AS,U,UA	.	.	.	.	.	.	.	.
VCZ2X4R (1)	AS,U,UA	.	.	.	.	.	.	.	.

Model	Ver	900	901	950	1000	1001
VCZ3X4L (1)	AF,AS,U,UA,UF	.	.	.	.	.
VCZ3X4R (1)	AF,AS,U,UA,UF	.	.	.	.	.

(1) The valves can be combined with the units if there is a control panel for managing them.

**Combined Adjustment and Balancing Valve Kit**

Model	Ver	100	101	102	150	200	201	202	250
VJP060 (1)	ACT,APC	.	.	.	.	.	.	.	.
	AS,U,UA	.	.	.	.	.	.	.	.
VJP060M (2)	ACT,APC	.	.	.	.	.	.	.	.
	AS,U,UA	.	.	.	.	.	.	.	.

Model	Ver	300	301	302	350	400	401	402	450
VJP060 (1)	ACT,APC	.	.	.	.	.	.	.	.
	AS,U,UA	.	.	.	.	.	.	.	.
VJP060M (2)	ACT,APC	.	.	.	.	.	.	.	.
	AS,U,UA	.	.	.	.	.	.	.	.

Model	Ver	500	501	502	550	600	601	602	650
VJP090 (1)	ACT,APC	.	.	.	.	.	.	.	.
	AS,U,UA	.	.	.	.	.	.	.	.
VJP090M (2)	ACT,APC	.	.	.	.	.	.	.	.
	AS,U,UA	.	.	.	.	.	.	.	.

Model	Ver	700	701	702	750	800	801	802	850
VJP150 (1)	ACT,APC	.	.	.	.	.	.	.	.
	AS,U,UA	.	.	.	.	.	.	.	.
VJP150M (2)	ACT,APC	.	.	.	.	.	.	.	.
	AS,U,UA	.	.	.	.	.	.	.	.

Model	Ver	900	901	950	1000	1001
VJP150 (1)	ACT,APC	.	.	.	.	.
	AS,U,UA	.	.	.	.	.

Model	Ver	900	901	950	1000	1001
VJP150M (2)	ACT,APC	.	.	.	.	.
	AS,U,UA	.	.	.	.	.

(1) 230V~50Hz  
(2) 24V

### (Heating only) additional coil

#### Heating only additional coil

Model	Ver	100	101	102	150	200	201	202	250
BV117 (1)	A,AF,AS,U,UA,UF	.							
BV122 (1)	A,AF,AS,U,UA,UF					.			
Model	Ver	300	301	302	350	400	401	402	450
BV132 (1)	A,AF,AS,U,UA,UF	.							
BV142 (1)	A,AF,AS,U,UA,UF					.			
Model	Ver	500	501	502	550	600	601	602	650
BV142 (1)	A,AF,AS,U,UA,UF	.							
BVZ800 (1)	A,AS,U,UA					.			
Model	Ver	700	701	702	750	800	801	802	850
BVZ800 (1)	A,AS,U,UA	.				.			
Model	Ver	900	901	950	1000	1001			
BV162 (1)	A,AF,AS,U,UA,UF	.			.	.			

(1) Not available for sizes with oversized main coil.

#### Electric coil - Requires a thermostat with heater management. Not available for sizes with an oversized main coil.

Model	Ver	100	101	102	150	200	201	202	250
RX17 (1)	AF,AS,U,UA,UF	.							
RX22 (1)	AF,AS,U,UA,UF					.			
Model	Ver	300	301	302	350	400	401	402	450
RX32 (1)	AF,AS,U,UA,UF	.							
RX42 (1)	AF,AS,U,UA,UF					.			
Model	Ver	500	501	502	550	600	601	602	650
RX52 (1)	AF,AS,U,UA,UF	.							
RXZ800 (1)	AS,U,UA					.			
Model	Ver	700	701	702	750	800	801	802	850
RXZ800 (1)	AS,U,UA	.				.			
Model	Ver	900	901	950	1000	1001			
RX62 (1)	AF,AS,U,UA,UF	.			.	.			

(1) Requires a thermostat with heater management. Not available for sizes with an oversized main coil. The PCR1 PCR2 or PCR1V appliance must also be provided depending on the unit.

### Installation accessories

#### Wall mounting kit

Ver	100	101	102	150	200	201	202	250
U, UA	AMP20	AMP20	AMP20	AMP20	AMP20	AMP20	AMP20	AMP20
UF	AMP20	-	-	AMP20	AMP20	-	-	AMP20
Ver	300	301	302	350	400	401	402	450
U, UA	AMP20	AMP20	AMP20	AMP20	AMP20	AMP20	AMP20	AMP20
UF	AMP20	-	-	AMP20	AMP20	-	-	AMP20
Ver	500	501	502	550	600	601	602	650
U, UA	AMP20	AMP20	AMP20	AMP20	AMPZ	AMPZ	AMPZ	AMPZ
UF	AMP20	-	-	AMP20	-	-	-	-

The accessory cannot be fitted on the configurations indicated with -

Ver	700	701	702	750	800	801	802	850
U, UA	AMPZ	AMPZ	AMPZ	AMPZ	AMPZ	AMPZ	AMPZ	AMPZ
Ver	900	901	950	1000	1001			
U, UA	AMPZ	AMPZ	AMPZ	AMPZ	AMPZ			

#### Condensate recirculation device

Model	Ver	100	101	102	150	200	201	202	250
DSCZ4 (1)	A,AS,U,UA	.	.	.	.	.	.	.	.
	ACT,APC	.	.	.	.	.	.	.	.
Model	Ver	300	301	302	350	400	401	402	450
DSCZ4 (1)	A,AS,U,UA	.	.	.	.	.	.	.	.
	ACT,APC	.	.	.	.	.	.	.	.
Model	Ver	500	501	502	550	600	601	602	650
DSCZ4 (1)	A,AS,U,UA	.	.	.	.	.	.	.	.
	ACT,APC	.	.	.	.	.	.	.	.

Model	Ver	700	701	702	750	800	801	802	850
DSCZ4 (1)	A,AS,U,UA	.	.	.	.	.	.	.	.
	ACT,APC	.	.	.	.	.	.	.	.

Model	Ver	900	901	950	1000	1001
DSCZ4 (1)	A,AS,U,UA	.	.	.	.	.
	ACT,APC	.	.	.	.	.

(1) DSCZ4 due to space problems inside the unit, the VCZ1-2-3-4 X4L/R valves cannot be mounted together with the amp/AMPZ accessories, with all the condensate collection trays. With the VMF-E19/E19I thermostats, please contact the head office.

#### Condensate drip

Model	Ver	100	101	102	150	200	201	202	250
BCZ4 (1)	A,AS,U,UA	.	.	.	.	.	.	.	.
	ACT,APC	.	.	.	.	.	.	.	.
BCZ5 (2)	A,AS,U,UA	.	.	.	.	.	.	.	.
	ACT,APC	.	.	.	.	.	.	.	.

Model	Ver	300	301	302	350	400	401	402	450
BCZ4 (1)	A,AS,U,UA	.	.	.	.	.	.	.	.
	ACT,APC	.	.	.	.	.	.	.	.
BCZ5 (2)	A,AS,U,UA	.	.	.	.	.	.	.	.
	ACT,APC	.	.	.	.	.	.	.	.

Model	Ver	500	501	502	550	600	601	602	650
BCZ4 (1)	A,AS,U,UA	.	.	.	.	.	.	.	.
	ACT,APC	.	.	.	.	.	.	.	.
BCZ5 (2)	A,AS,U,UA	.	.	.	.	.	.	.	.
	ACT,APC	.	.	.	.	.	.	.	.

Model	Ver	700	701	702	750	800	801	802	850
BCZ4 (1)	A,AS,U,UA	.	.	.	.	.	.	.	.
	ACT,APC	.	.	.	.	.	.	.	.
BCZ5 (2)	A,AS,U,UA	.	.	.	.	.	.	.	.
	ACT,APC	.	.	.	.	.	.	.	.

Model	Ver	900	901	950	1000	1001
BCZ4 (1)	A,AS,U,UA	.	.	.	.	.
	ACT,APC	.	.	.	.	.
BCZ6 (2)	A,AS,U,UA	.	.	.	.	.
	ACT,APC	.	.	.	.	.

(1) For vertical installation.

(2) For horizontal installation.

#### Panel closing the rear of the unit

Model	Ver	100	101	102	150	200	201	202	250
PCZ100	A,AS,U,UA	.	.	.	.	.	.	.	.
	ACT,APC	.	.	.	.	.	.	.	.
PCZ200	A,AS,U,UA	.	.	.	.	.	.	.	.
	ACT,APC	.	.	.	.	.	.	.	.

Model	Ver	300	301	302	350	400	401	402	450
PCZ300	A,AS,U,UA	.	.	.	.	.	.	.	.
	ACT,APC	.	.	.	.	.	.	.	.
PCZ500	A,AS,U,UA	.	.	.	.	.	.	.	.
	ACT,APC	.	.	.	.	.	.	.	.

Model	Ver	500	501	502	550	600	601	602	650
PCZ500	A,AS,U,UA	.	.	.	.	.	.	.	.
	ACT,APC	.	.	.	.	.	.	.	.
PCZ800	A,AS,U,UA	.	.	.	.	.	.	.	.
	ACT,APC	.	.	.	.	.	.	.	.

Model	Ver	700	701	702	750	800	801	802	850
PCZ800	A,AS,U,UA	.	.	.	.	.	.	.	.
	ACT,APC	.	.	.	.	.	.	.	.

Model	Ver	900	901	950	1000	1001
PCZ1000	A,AS,U,UA	.	.	.	.	.
	ACT,APC	.	.	.	.	.

#### Lower intake grille

Model	Ver	100	101	102	150	200	201	202	250
GA100	U,UA	.	.	.	.	.	.	.	.
GA200	U,UA	.	.	.	.	.	.	.	.

Model	Ver	300	301	302	350	400	401	402	450
GA300	U,UA	.	.	.	.	.	.	.	.
GA500	U,UA	.	.	.	.	.	.	.	.

Model	Ver	500	501	502	550	600	601	602	650
GA500	U,UA	.	.	.	.				
GA800	U,UA					.	.	.	.
Model	Ver	700	701	702	750	800	801	802	850
GA800	U,UA	.	.	.	.	.	.	.	.
Model	Ver	900	901	950	1000	1001			
GA800	U,UA	.	.	.	.	.			

**Supports to be combined with the ornamental grille (GA) for floor installation of the fan coil**

Model	Ver	100	101	102	150	200	201	202	250
FIKIT100	A,AS,U,UA	.	.	.	.				
	ACT,AF,APC,UF	.			.				
FIKIT200	A,AS,U,UA					.	.	.	.
	ACT,AF,APC,UF					.			.
Model	Ver	300	301	302	350	400	401	402	450
FIKIT300	A,AS,U,UA	.	.	.	.				
	ACT,AF,APC,UF	.			.				
FIKIT500	A,AS,U,UA					.	.	.	.
	ACT,AF,APC,UF					.			.
Model	Ver	500	501	502	550	600	601	602	650
FIKIT500	A,AS,U,UA	.	.	.	.				
	ACT,AF,APC,UF	.			.				
FIKIT800	A,AS,U,UA					.	.	.	.
	ACT,APC					.			.
Model	Ver	700	701	702	750	800	801	802	850
FIKIT800	ACT,APC	.			.	.			.
	U,UA	.	.	.	.	.	.	.	.
Model	Ver	900	901	950	1000	1001			
FIKIT800	A,AS,U,UA	.	.	.	.	.			.
	ACT,AF,APC,UF	.			.	.	.		.

**Pair of stylish structural feet**

Model	Ver	100	101	102	150	200	201	202	250
ZXZ	A,AS,U,UA	.	.	.	.	.	.	.	.
	ACT,APC	.			.	.			.
Model	Ver	300	301	302	350	400	401	402	450
ZXZ	A,AS,U,UA	.	.	.	.	.	.	.	.
	ACT,APC	.			.	.			.
Model	Ver	500	501	502	550	600	601	602	650
ZXZ	A,AS,U,UA	.	.	.	.	.	.	.	.
	ACT,APC	.			.	.			.
Model	Ver	700	701	702	750	800	801	802	850
ZXZ	A,AS,U,UA	.	.	.	.	.	.	.	.
	ACT,APC	.			.	.			.
Model	Ver	900	901	950	1000	1001			
ZXZ	A,AS,U,UA	.	.	.	.	.			.
	ACT,APC	.			.	.	.		.

## PERFORMANCE SPECIFICATIONS

### 2-pipe

	FCZ100			FCZ150			FCZ200			FCZ250			FCZ300			FCZ350			FCZ400			FCZ450			FCZ500			FCZ550								
	1	2	3	1	2	3	1	2	3	1	2	3	1	2	3	1	2	3	1	2	3	1	2	3	1	2	3	1	2	3	1	2	3			
	L	M	H	L	M	H	L	M	H	L	M	H	L	M	H	L	M	H	L	M	H	L	M	H	L	M	H	L	M	H	L	M	H	L	M	H
Heating performance 70 °C / 60 °C (1)																																				
Heating capacity	kW			1,45	2,00	2,40	1,55	2,19	2,65	2,02	2,95	3,70	2,20	3,18	4,05	3,47	4,46	5,50	3,77	4,92	6,15	4,32	5,74	7,15	4,57	6,29	7,82	5,27	7,31	8,50	5,82	8,34	9,75			
Water flow rate system side	l/h			125	172	206	136	192	232	177	258	324	193	278	355	304	391	482	330	431	539	379	503	627	400	551	685	462	641	745	510	731	855			
Pressure drop system side	kPa			4	7	9	5	9	12	6	12	18	7	15	23	7	12	18	8	14	20	9	16	24	6	11	16	12	21	28	10	20	26			
Heating performance 45 °C / 40 °C (2)																																				
Heating capacity	kW			0,72	0,99	1,19	0,77	1,09	1,31	1,00	1,46	1,84	1,09	1,58	2,01	1,72	2,21	2,73	1,87	2,44	3,06	2,14	2,85	3,55	2,27	3,12	3,88	2,62	3,63	4,22	2,89	4,14	4,85			
Water flow rate system side	l/h			126	173	207	134	189	229	174	254	319	190	274	350	299	385	475	325	425	531	373	495	617	394	543	675	455	631	734	502	720	842			
Pressure drop system side	kPa			4	7	10	5	9	12	6	12	18	8	15	22	8	12	18	8	14	20	10	16	24	6	11	16	12	21	28	10	20	26			
Cooling performance 7 °C / 12 °C																																				
Cooling capacity	kW			0,65	0,84	1,00	0,80	1,06	1,27	0,89	1,28	1,60	1,06	1,55	1,94	1,68	2,17	2,65	1,89	2,46	3,02	2,20	2,92	3,60	2,41	3,21	4,03	2,68	3,69	4,25	2,91	4,13	4,79			
Sensible cooling capacity	kW			0,51	0,69	0,83	0,57	0,80	0,97	0,71	1,05	1,33	0,79	1,20	1,52	1,26	1,65	2,04	1,33	1,76	2,18	1,59	2,14	2,67	1,69	2,30	2,90	1,94	2,73	3,18	2,07	2,98	3,49			
Water flow rate system side	l/h			112	144	172	138	182	219	153	221	275	182	267	334	288	374	456	350	460	560	379	503	619	414	552	694	460	634	731	501	711	824			
Pressure drop system side	kPa			4	6	8	6	12	13	6	12	18	8	17	25	8	13	18	11	18	25	10	16	24	9	15	22	13	22	29	12	22	28			
Fan																																				
Type	type																																			
Fan motor	type																																			
Number	no.																																			
Air flow rate	m <sup>3</sup> /h																																			
Input power	W																																			
Electrical wiring	V1 V2 V3 V1 V2 V3 V1 V2 V3 V1 V2 V3 V1 V2 V3 V1 V2 V3 V1 V2 V3 V1 V2 V3 V1 V2 V3 V1 V2 V3																																			
Fan coil sound data (3)																																				
Sound power level	dB(A)			31,0	38,0	45,0	31,0	38,0	45,0	35,0	46,0	51,0	35,0	46,0	51,0	34,0	41,0	48,0	34,0	41,0	48,0	37,0	44,0	51,0	37,0	44,0	51,0	42,0	51,0	56,0	42,0	51,0	56,0			
Sound pressure level	dB(A)			23,0	30,0	37,0	23,0	30,0	37,0	27,0	38,0	43,0	27,0	38,0	43,0	26,0	33,0	40,0	26,0	33,0	40,0	29,0	36,0	43,0	29,0	36,0	43,0	34,0	43,0	48,0	34,0	43,0	48,0			
Diameter hydraulic fittings																																				
Main heat exchanger	Ø			1/2"			1/2"			1/2"			1/2"			3/4"			3/4"			3/4"			3/4"			3/4"			3/4"					
Power supply																																				
Power supply	230V~50Hz																																			

	FCZ600			FCZ650			FCZ700			FCZ750			FCZ800			FCZ850			FCZ900			FCZ950			FCZ1000								
	1	2	3	1	2	3	1	2	3	1	2	3	1	2	3	1	2	3	1	2	3	1	2	3	1	2	3	1	2	3			
	L	M	H	L	M	H	L	M	H	L	M	H	L	M	H	L	M	H	L	M	H	L	M	H	L	M	H	L	M	H	L	M	H
Heating performance 70 °C / 60 °C (1)																																	
Heating capacity	kW			6,50	8,10	10,00	7,19	9,15	11,50	8,10	9,80	11,00	9,10	11,30	12,50	9,80	10,80	12,00	11,30	12,35	14,00	10,77	13,35	15,14	11,20	14,42	17,10	12,53	15,24	17,02			
Water flow rate system side	l/h			570	710	877	631	802	1008	710	860	964	798	991	1096	859	947	1052	991	1083	1227	945	1171	1328	982	1264	1500	1101	1337	1493			
Pressure drop system side	kPa			12	18	26	14	21	31	17	24	29	10	15	18	22	27	32	17	20	25	12	17	22	16	24	33	22	32	38			
Heating performance 45 °C / 40 °C (2)																																	
Heating capacity	kW			3,32	4,03	4,97	3,57	4,55	5,72	4,03	4,87	5,47	4,52	5,62	6,21	4,87	5,37	5,97	5,62	6,14	6,96	5,35	6,64	7,53	5,57	7,17	8,50	6,24	7,58	8,46			
Water flow rate system side	l/h			561	699	863	621	790	993	699	846	950	786	975	1079	846	932	1036	975	1066	1209	930	1152	1307	967	1245	1476	1084	1316	1469			
Pressure drop system side	kPa			12	18	26	14	20	31	16	24	29	10	14	18	22	26	32	6	20	25	12	17	22	15	24	33	22	31	38			
Cooling performance 7 °C / 12 °C																																	
Cooling capacity	kW			3,22	3,90	4,65	3,95	4,80	5,67	3,92	4,89	5,50	4,27	5,34	6,14	4,84	5,66	6,10	5,26	6,29	6,91	4,29	5,00	6,91	5,77	7,32	8,60	5,69	6,88	7,62			
Sensible cooling capacity	kW			2,56	3,17	3,92	2,78	3,43	4,12	2,99	3,76	4,30	3,20	4,05	4,72	3,72	4,42	4,83	4,00	4,83	5,36	2,97	3,78	5,68	3,80	4,87	5,78	4,42	5,34	5,53			
Water flow rate system side	l/h			554	671	800	595	825	975	675	841	946	734	918	1056	833	974	1049	904	1082	1189	738	860	1189	992	1259	1479	979	1183	1311			
Pressure drop system side	kPa			14	19	26	15	21	28	16	24	30	10	14	18	20	26	30	14	20	23	10	12	22	15	22	30	22	31	36			
Fan																																	
Type	type																																
Fan motor	type																																
Number	no.																																
Air flow rate	m <sup>3</sup> /h																																
Input power	W																																
Electrical wiring	V1 V2 V3 V1 V2 V3 V1 V2 V3 V1 V2 V3 V1 V2 V3 V1 V2 V3 V1 V2 V3 V1 V2 V3 V1 V2 V3 V1 V2 V3																																
Fan coil sound data (3)																																	
Sound power level	dB(A)			42,0	51,0	57,0	42,0	51,0	57,0	50,0	57,0	62,0	50,0	57,0	62,0	56,0	61,0	66,0	56,0	61,0	66,0	61,0	66,0	71,0	62,0	71,0	77,0	62,0	71,0	77,0	66,0	75,0	81,0
Sound pressure level	dB(A)			34,0	43,0	49,0	34,0	43,0	49,0	42,0	49,0	54,0	42,0	49,0	54,0	48,0	53,0	58,0	48,0	53,0	58,0	53,0	58,0	63,0	54,0	63,0	69,0	54,0	63,0	69,0	58,0	67,0	73,0
Diameter hydraulic fittings																																	
Main heat exchanger	Ø																											3/4"					
Power supply																																	
Power supply	230V~50Hz																																

(1) Room air temperature 20 °C d.b.; Water (in/out) 70 °C/60 °C

(2) Room air temperature 20 °C d.b.; Water (in/out) 45 °C/40 °C; EUROVENT

(3) Aermec determines the sound power value on the basis of measurements taken in accordance with standard UNI EN 16583:15, respecting the Eurovent certification.

4-pipe

	FCZ101			FCZ201			FCZ301			FCZ401			FCZ501			FCZ601			FCZ701			FCZ801			FCZ901			FCZ1001					
	1	2	3	1	2	3	1	2	3	1	2	3	1	2	3	1	2	3	1	2	3	1	2	3	1	2	3	1	2	3	1	2	3
	L	M	H	L	M	H	L	M	H	L	M	H	L	M	H	L	M	H	L	M	H	L	M	H	L	M	H	L	M	H	L	M	H
Heating performance 65 °C / 55 °C (1)																																	
Heating capacity	kW																																
Water flow rate system side	l/h																																
Pressure drop system side	kPa																																
Cooling performance 7 °C / 12 °C																																	
Cooling capacity	kW																																
Sensible cooling capacity	kW																																
Water flow rate system side	l/h																																
Pressure drop system side	kPa																																
Fan																																	
Type	Centrifugal																																
Fan motor	Asynchronous																																
Number	no.																																
Air flow rate	m³/h																																
Input power	W																																
Electrical wiring	V1 V2 V3 V1 V2 V3 V1 V2 V3 V1 V2 V3 V1 V2 V3 V1 V2 V3 V1 V2 V3 V1 V2 V3 V1 V2 V3 V1 V2 V3																																
Fan coil sound data (2)																																	
Sound power level	dB(A)																																
Sound pressure level	dB(A)																																
Diameter hydraulic fittings																																	
Main heat exchanger	Ø																																
Secondary heat exchanger	Ø																																
Power supply																																	
Power supply	230V~50Hz																																

(1) Room air temperature 20°C d.b.; Water (in/out) 65 °C/55 °C; EUROVENT

(2) Aermec determines the sound power value on the basis of measurements taken in accordance with standard UNI EN 16583:15, respecting the Eurovent certification.

**DIMENSIONS**

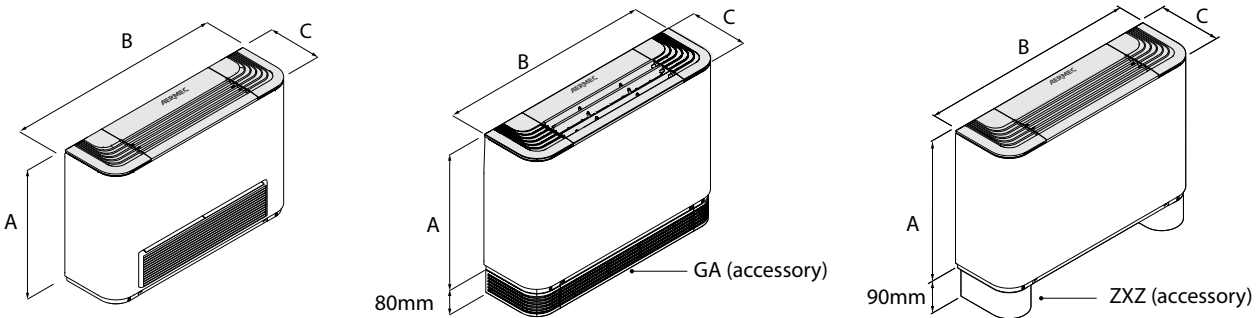

	FCZ100	FCZ101	FCZ102	FCZ150	FCZ200	FCZ201	FCZ202	FCZ250	FCZ300	FCZ301	FCZ302	FCZ350	FCZ400	FCZ401	FCZ402	FCZ450
<b>Dimensions and weights</b>																
A	mm															
B	mm															
C	mm															
Empty weight	kg															
	FCZ500	FCZ501	FCZ502	FCZ550	FCZ600	FCZ601	FCZ602	FCZ650	FCZ700	FCZ701	FCZ702	FCZ750	FCZ800	FCZ801	FCZ802	FCZ850
<b>Dimensions and weights</b>																
A	mm															
B	mm															
C	mm															
Empty weight	kg															
	FCZ900			FCZ901			FCZ950			FCZ1000			FCZ1001			
<b>Dimensions and weights</b>																
A	mm															
B	mm															
C	mm															
Empty weight	kg															

Aermec reserves the right to make any modifications deemed necessary. All data is subject to change without notice. Aermec does not assume responsibility or liability for errors or omissions.

**Aermec S.p.A.**  
Via Roma, 996 - 37040 Bevilacqua (VR) - Italia  
Tel. 0442633111 - Telefax 044293577  
www.aermec.com