

EN

19.07 - 6228091\_02  
Original instructions

# H M I

## Technical Manual



### AIR-WATER HEAT PUMP

Cooling capacity 3 - 13 kW

Heating capacity 4 - 15.5 kW



Dear customer,

Thank you for choosing an AERMEC product. It is the fruit of many years of experience and special design studies and has been made of the highest grade materials and with cutting edge technology.

In addition, all our products bear the EC mark indicating that they meet the requirements of the European Machine Directive regarding safety. The quality level is being constantly monitored, so AERMEC products are synonymous with Safety, Quality and Reliability.

**The data may undergo modifications considered necessary for the improvement of the product, at any time and without the obligation for any notice thereof.**

Thank you once again.  
AERMEC S.p.A







This marking indicates that this product should not be disposed with other household wastes throughout the EU. To prevent possible harm to the environment or human health from uncontrolled disposal of Waste Electrical and Electronic Equipment (WEEE), please return the device using appropriate collection systems, or contact the retailer where the product was purchased. Please contact your local authority for further details.







Illegal dumping of the product by the user entails the application of administrative sanctions provided by law.

---

All specifications are subject to change without prior notice. Although every effort has been made to ensure accuracy, Aermec shall not be held liable for any errors or omissions.

---

				
50Hz	Refrigerant gas R32	Cooling and heating	DHW	Compresseur rotatif à Inverter
50Hz	R32 refrigerant	Cooling and heating	DHW	Inverter rotary compressor
50Hz	Réfrigérant R32	Refroidissement et chauffage	ECS	Compresseur rotatif à inverseur
50Hz	R32-Kältemittel	Kühlung und Heizung	BWW	Inverter-Rollkolbenverdichter
50Hz	Refrigerant gas R32	Frío y calor	DHW	Compresor rotativo inverter

					
Inverter axial flow fan	Plate heat exchanger	Pumping assembly	ModBus protocol	For 2-pipe systems	WiFi module
Inverter axial fan	Plate exchanger	Pump kit	ModBus protocol	For 2-pipe systems	WiFi module
Ventilateur axial à inverseur	Échangeur à plaques	Kit pompe	Protocole ModBus	Pour installations deux tubes	Module WiFi
Inverter-Axialventilator	Plattenwärmetauscher	Pumpensatz	Mit ModBus-Protokoll	Für 2-Rohr-Anlagen	WiFi-Modul
Ventilador axial inverter	Intercambiador de placas	Kit de bomba	Protocolo ModBus	Para plantas de dos tubos	Módulo WiFi

## INDEX

CHARACTERISTICS OF THE RANGE .....	6
CONFIGURATOR .....	7
DESCRIPTION OF THE COMPONENTS OF THE STANDARD UNIT .....	8
COOLING DIAGRAMS .....	11
ACCESSORIES .....	12
TECHNICAL PERFORMANCE DATA DECLARED EUROVENT - 14511:2013 .....	13
TECHNICAL PERFORMANCE DATA - 14511:2018 .....	14
GENERAL TECHNICAL DATA .....	15
DIMENSIONS - WEIGHTS - MINIMUM TECHNICAL CLEARANCES .....	16
OPERATING LIMITS .....	17
OUTPUT AND INPUT VALUES DIFFERENT FROM NOMINAL .....	18
USEFUL HEAD VALUES .....	24
GLYCOL .....	27
SOUND DATA .....	28

## COMPANY CERTIFICATIONS



## PERFORMANCE CERTIFICATIONS



Aermec participates in the EUROVENT program: LCP  
The products involved can be found on the website  
[www.eurovent-certification.com](http://www.eurovent-certification.com)

## SAFETY CERTIFICATIONS



## CHARACTERISTICS OF THE RANGE

Reversible air/water heat pump Inverter for air conditioning systems with chilled water production for cooling rooms and hot water for heating and/or domestic hot water services, suitable for connection with small or medium users. Special attention was paid to the winter mode, improving the working range compared with standard heat pumps so as to guarantee production of hot water up to 60°C and extending operation down to an outside air temperature of -25°C. The unit is equipped with a twin rotary DC inverter compressor, axial flow fans and a plate heat exchanger. Ready for immediate installation, it can be combined not only with low-temperature emission systems such as floor heating or fan coils, but also the most traditional radiators.

### Operating limits

Works at full load down to -25°C (outside air temperature in winter), and up to 48°C in summer. Maximum processed water temperature in heating mode - 60°C.

### Brushless DC axial flow fans

Designed for aerodynamic optimisation, they reduce the noise level but at the same time increase the efficiency and air flow rate.

### Heat exchanger, source side

Heat exchanger coils with Golden Fin anti-corrosion protection. The aluminium-manganese (Al-Mn) coil fins are coated with a special layer of epoxy resin, which gives them a characteristic golden colour, and then a hydrophilic layer.

### Base electric heater

To avoid the formation of ice in heating mode.

### Emergency operation (a supplementary heat source may be activated)

Quick domestic hot water heating function (Quick Hot Water)

Weather Dependent Mode (climatic adjustment)

Quiet function for reduced noise operation (programmable with a timer)

Condensation Control

When the anti-legionella cycle is activated (it's easily set via the control panel), the whole tank is heated once a week to a temperature (max. 70°C) that weakens the bacteria responsible for the infection.

### Coastal marine environments

Coastal or marine environments are characterized by the abundance of sodium chloride (salt) which is carried by sea spray, mist, or fog. Most importantly, this salt water can be carried more than several miles by ocean breezes and tidal currents. It's not uncommon to experience salt-water contamination as far as 10km from the coast. For this reason, it may be necessary to protect the equipment from electrolytes of marine origin.

### Industrial environments

Industrial applications are associated with a host of diverse conditions with the potential to produce various atmospheric emissions.

Sulphur and nitrogen oxide contaminants are usually linked to high-density urban environments. The combustion of coal oil and fuel oils releases sulphur oxides (SO<sub>2</sub>, SO<sub>3</sub>) and nitrogen oxides (NO<sub>x</sub>) into the atmosphere. These gases accumulate in the atmosphere and return to the ground in the form of acid rain or low pH dew.

Not only are industrial emissions potentially corrosive, but many industrial dust particles can be laden with harmful elements like metal oxides, chlorides, sulphates, sulphuric acid, carbon, and carbon compounds.

These particles, in the presence of oxygen, water, or high humidity environments can be highly corrosive and may lead to many forms of corrosion including general corrosion and localized corrosion such as pitting and formicary corrosion.

### Combination of marine and industrial environments

Salt-laden seawater mist, combined with the harmful emissions of an industrial environment, poses a severe threat.

The combined effects of salt mist and industrial emissions will speed up corrosion.

Internally in manufacturing plants, corrosive gases may be the result of process chemicals or the typical industrial processes employed in manufacturing activities.

Open sewage systems, vents, diesel exhaust, emissions from dense traffic, landfills, aircraft and ocean vessel exhaust, industrial manufacturing, chemical treatment facilities (cooling towers nearby) and fossil fuel power stations are all potential contributors that must be taken into consideration.

### Urban environments

Highly populated areas generally have high levels of automobile emissions and an increased use of fuels for heating the buildings.

Both these conditions raise the concentration of sulphur oxide (SO<sub>2</sub>) and nitrogen oxide (NO<sub>x</sub>). Inside a building, gases can be produced by cleaning substances, cigarette smoke, process operations and data center printers.

In some indoor environments such as swimming pool areas and water treatment facilities can also produce corrosive atmospheres.

Corrosion severity in this environment is a function of the pollution levels, which in turn depend on several factors including population density in the area.

Any equipment installed immediately adjacent to diesel exhaust, incinerator discharge stacks, fuel-burning boiler stacks, or areas exposed to fossil fuel combustion emissions,

should be considered an industrial application.

### Rural environments

Rural environments may contain high levels of ammonia and nitrogen contamination from animal excrement, fertilizers, and high concentrations of diesel exhaust. These environments should be handled much like industrial applications.

The local weather conditions play a major role in concentrating or dispersing external gaseous contaminants.

Temperature inversions can trap pollutants, producing a serious air pollution problem.

### Additional precautions

Although each of the corrosive environments listed above can be detrimental to the life of a heat exchanger, many other factors should also be considered before making a final design selection.

The local climate around the application site may be subject to:

- wind
- dust
- road salts
- swimming pools
- diesel exhaust / traffic
- localised fog
- household cleaning agents
- sewer vents
- and many other individual contaminants

Even being within 3-5km of these special local climates may reclassify a normally moderate environment as one requiring corrosion prevention measures. When these factors are a direct part of the immediate environment, their influence is further exacerbated.

## CONFIGURATOR

Field	Description
1,2,3	HMI
4,5,6	Size 040-060-080-100-120-140-160
8	Power supply 220-240V/1/50Hz
T	380-415V/3N/50Hz <sup>(1)</sup>

<sup>(1)</sup> Only for sizes HMI 100-120-140-160

# DESCRIPTION OF THE COMPONENTS OF THE STANDARD UNIT

## COOLING CIRCUIT

### Twin rotary DC inverter compressor

2-stage twin rotary DC inverter compressor. All the compressors are fitted with a heater casing and internal electronic thermal protection.

### Heat exchanger, service side

Braze welded plate heat exchanger in steel. Coated with an anti-condensation material in closed cell neoprene.

When the unit is not functioning, it's protected against the formation of ice by an electric heater.

### Heat exchanger, source side

Heat exchanger coils with Golden Fin anti-corrosion protection. The aluminium-manganese (Al-Mn) coil fins are coated with a special layer of epoxy resin, which gives them a characteristic golden colour, and then a hydrophilic layer.

### Cycle inversion valve

4-way cycle inversion valve. Reverses the refrigerant fluid flow.

### Economiser

Economiser circuit with plate heat exchanger; allows to increase the performance, especially with the high compression ratios, for example in case of low external temperatures during winter operation.

### Fluid separator

Positioned on the intake line to protect the compressor from any possible liquid return.

### Cooling circuit filter

Mechanically sealed type made of hygroscopic material, to trap impurities and any traces of humidity in the cooling circuit.

### Solenoid valves

The valves close when the compressor is switched off, preventing the refrigerant gas from flowing towards the evaporator - recovery and coil.

### Electronic thermostatic valve

Compared with a mechanical thermostatic valve, the electronic one offers better over-heating control so the evaporator is used more efficiently in all conditions, thereby boosting machine output.

Its use in comfort dedicated applications allows to make substantial benefits especially in the presence of varying loads, because it allows you to maintain the maximum efficiency with any external air temperature.

In industrial applications, where there is often a need to make temperature changes in a wide range of environmental conditions, the use of the electronic valve is ideal because it avoids the need for continuous calibration, adapting the system to different load conditions and hence making it independent.

## HYDRAULIC COMPONENTS

### Water filter

Fitted with steel filtering mesh to prevent the heat exchangers (service side) from getting clogged up by impurities in the circuit.

■ *Water filter supplied as standard (must be fitted, otherwise the warranty will be invalidated).*

### Flow switch

Checks that water is circulating in the heat exchanger, and stops the unit if this is not the case.

### Air drain valve

Works automatically to release any air pockets that may be present in the hydraulic circuit.

### Expansion tank

Membrane type with nitrogen pre-loading.

### Inverter pump

Provides the system with a useful head net of the unit pressure drops.

### Safety valve

Calibrated at 3 bar and with conveyed discharge, it bleeds off the excess pressure in the event of an anomalous pressure value.

## CHARACTERISTICS OF THE WATER

System: Chiller with plate heat exchanger	
PH	7.5-9
Electric conductivity	10-500µS/cm
Total hardness	4.5-8.5°dH
Temperature	< 65°C
Oxygen content	< 0.1 ppm
Max. glycol amount	50%
Phosphates (PO4)	< 2ppm
Manganese (Mn)	< 0.05 ppm
Iron (Fe)	< 0.3 ppm
Alkalinity (HCO3)	70 - 300 ppm
Chloride ions (Cl-)	< 50 ppm
Sulphate ions (SO4)	< 50 ppm
Sulphide ion (S)	none
Ammonium ions (NH4)	none
Silica (SiO2)	< 30ppm

## STRUCTURE

RAL 9002

Load-bearing structure for outdoor installation, in hot galvanised sheet steel painted with polyester powders and designed to ensure maximum accessibility for service and maintenance.

Equipped with an electric heater in the base to avoid the formation of ice in heating mode.

## BRUSHLESS DC AXIAL FLOW FANS

Fitted with accident prevention protection and consisting of axial flow fans and a motor with a protection rating of IP44. In addition, the motor has internal thermal protection with automatic reset.

Condensation control via a device that continuously adjusts the fan speed.

Fan speed is electronically controlled, so it is automatically increased to ensure constant good unit operation in the event of critical ambient conditions.

## CONTROL AND SAFETY COMPONENTS

### LOW pressure switch

With fixed calibration and located on the low pressure side of the refrigerant circuit, it stops compressor operation in the event of anomalous work pressure values.

### HIGH pressure switch

With fixed calibration, placed on the high pressure side of the refrigerant circuit, it shuts down compressor operation in the case of abnormal operating pressure.

### High pressure transducer

Placed on the high pressure side of the refrigerant circuit, it communicates to the control card the operating pressure, sending a pre-alarm in case of abnormal pressure.

## MICROPROCESSOR CONTROL

Pioneering electronic adjustment.

Via the touch screen control panel, in three languages (Italian, English and Spanish).

Management of a 3-way diverting valve (not supplied) for the production of domestic hot water.

Management of a 2-way valve (not supplied) for shutting off part of the system.

Weekly programming, in time bands.

Auto-Restart.

# INSTALLATION - HYDRAULIC DIAGRAMS

## INTERNAL AND EXTERNAL HMI HYDRAULIC CIRCUIT

### COMPONENTS SUPPLIED AS STANDARD

1. Plate heat exchanger
2. Water filter (supplied)
3. Flow switch
4. Air drain valve
5. Water temperature probes (IN/OUT)
9. Expansion tank
12. Pump
21. Safety valve

### RECOMMENDED HYDRAULIC COMPONENTS EXTERNAL TO THE UNIT (THE RESPONSIBILITY OF THE INSTALLER)

4. Air drain valve
6. Anti-vibration joints
7. Interception taps
9. Expansion tank
10. System storage tank (installation recommended if the system water content is lower than the value indicated in the technical manual).
13. Electric heater
14. Discharge tap
15. 3-way valve
17. HBI\_WT accessory
19. Charging unit

### WARNING:

in the case of a free-standing system, the bypass valve must be installed to ensure the circulation of a minimum amount of water to the system.

### CHARACTERISTICS OF THE WATER

System: Heat pump with plate heat exchanger	
pH (25°C)	6,8~8,0
Electric conductivity (25°C)	< 300 µS/cm
Total hardness (limestone CaCO <sub>3</sub> )	< 70 mg/L
Temperature	< 60°C
Oxygen content	< 3 mg/L
Max. glycol amount	50%
Phosphates (PO <sub>4</sub> )	< 2ppm
Manganese (Mn)	< 0,05 ppm
Iron (Fe)	< 0,3 mg/L
Alkalinity (CaCO <sub>3</sub> )	< 50 mg/L
Chloride ions (Cl <sup>-</sup> )	< 50 mg/L
Sulphate ions (SO <sub>4</sub> )	< 50 mg/L
Sulphide ion (S)	none
Ammonium (count N)	< 0,5 mg/L
Silica (SiO <sub>2</sub> )	< 30 mg/L
Cloudy	< 1 NTU
Chloride	< 50 mg/L
Fluoride	< 1 mg/L
Nitrate (count N)	< 10 mg/L
Ammonia (count N)	< 0,5 mg/L
Natrium	< 150 mg/L

## EXAMPLE 1 - CONFIGURATION: FREE-STANDING SYSTEM / FANCOIL + DHW

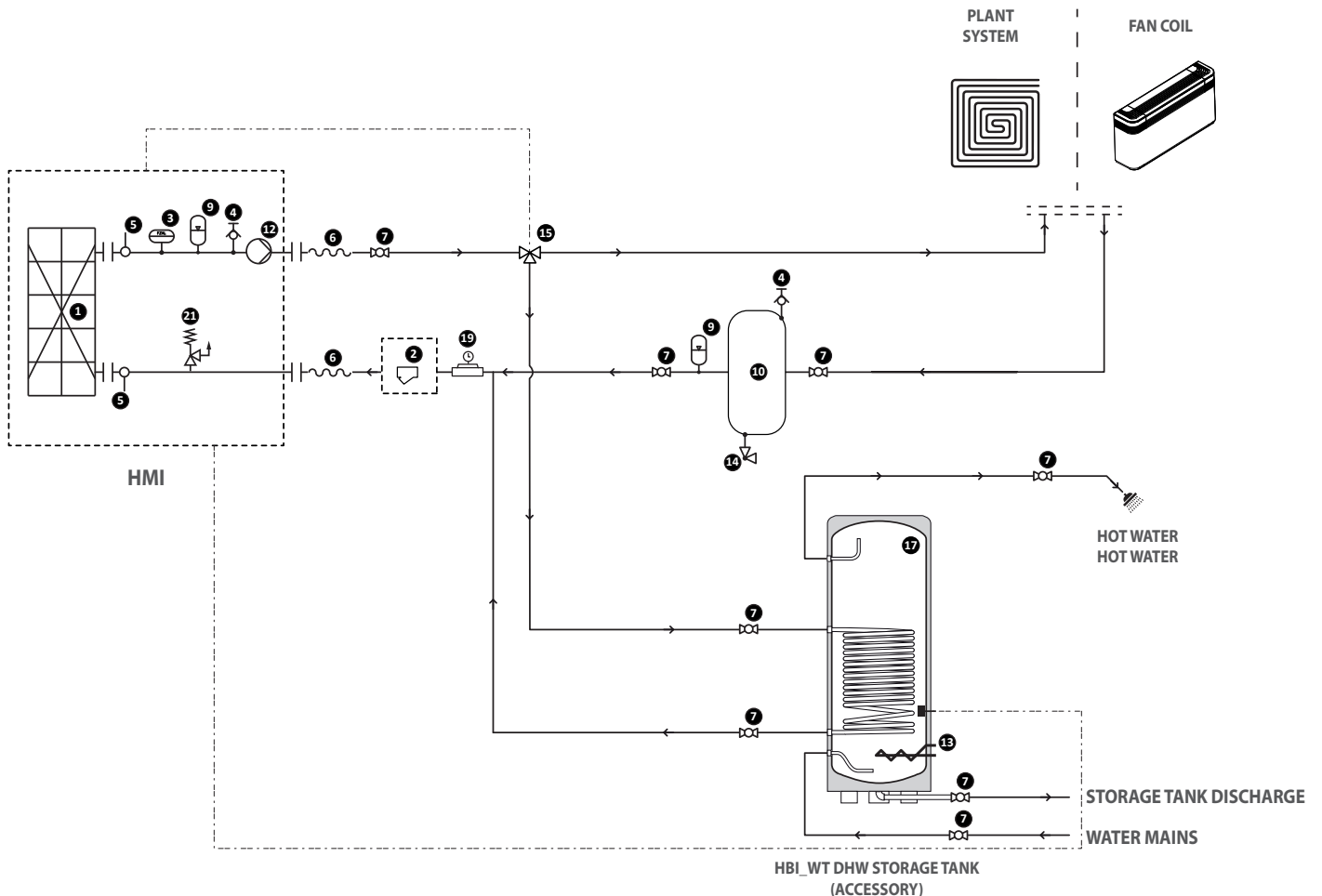

## INTERNAL AND EXTERNAL HMI HYDRAULIC CIRCUIT

### INTERNAL AND EXTERNAL HMI HYDRAULIC CIRCUIT

#### COMPONENTS SUPPLIED AS STANDARD

1. Plate heat exchanger
2. Water filter (supplied)
3. Flow switch
4. Air drain valve
5. Water temperature probes (IN/OUT)
9. Expansion tank
12. Pump
21. Safety valve

#### RECOMMENDED HYDRAULIC COMPONENTS EXTERNAL TO THE UNIT (THE RESPONSIBILITY OF THE INSTALLER)

4. Air drain valve
6. Anti-vibration joints
7. Interception taps
9. Expansion tank
10. System storage tank (installation recommended if the system water content is lower than the value indicated in the technical manual).
13. Electric heater
14. Discharge tap
15. 3-way valve
16. 2-way valve
17. HBI\_WT accessory
18. Additional heat source
19. Charging unit
22. Water temperature probe (optional) - SUPPLIED

#### CHARACTERISTICS OF THE WATER

System: Chiller with plate heat exchanger	
PH	7.5-9
Electric conductivity	10-500µS/cm
Total hardness	4.5-8.5°dH
Temperature	< 65°C
Oxygen content	< 0.1 ppm
Max. glycol amount	50%
Phosphates (PO4)	< 2ppm
Manganese (Mn)	< 0.05 ppm
Iron (Fe)	< 0.3 ppm
Alkalinity (HCO3)	70 - 300 ppm
Chloride ions (Cl-)	< 50 ppm
Sulphate ions (SO4)	< 50 ppm
Sulphide ion (S)	none
Ammonium ions (NH4)	none
Silica (SiO2)	< 30ppm

### EXAMPLE 2 - CONFIGURATION: FANCOIL + RADIATORS-DESIGNER RADIATORS + DHW + SUPPLEMENTARY HEAT SOURCE

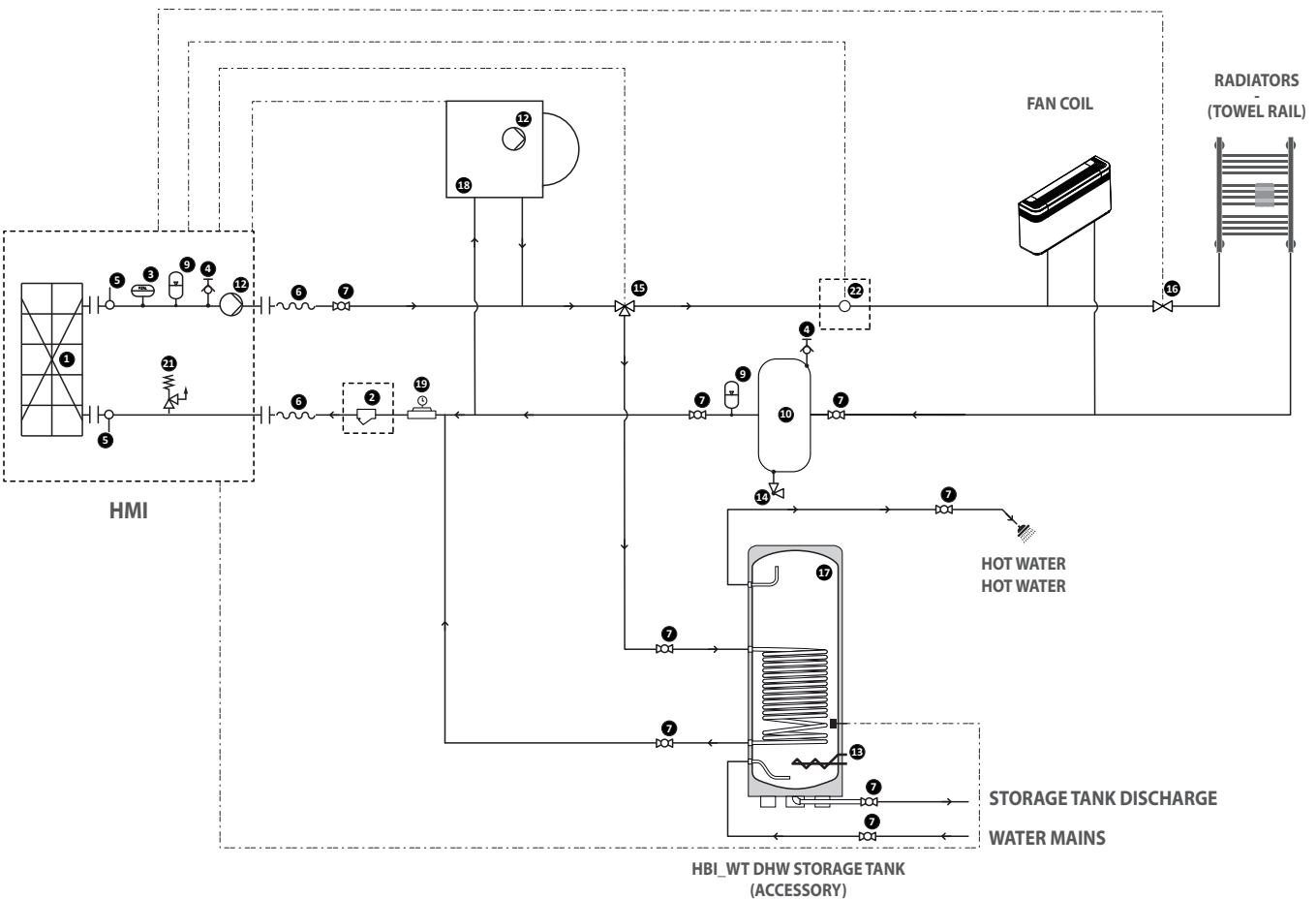

## COOLING DIAGRAMS

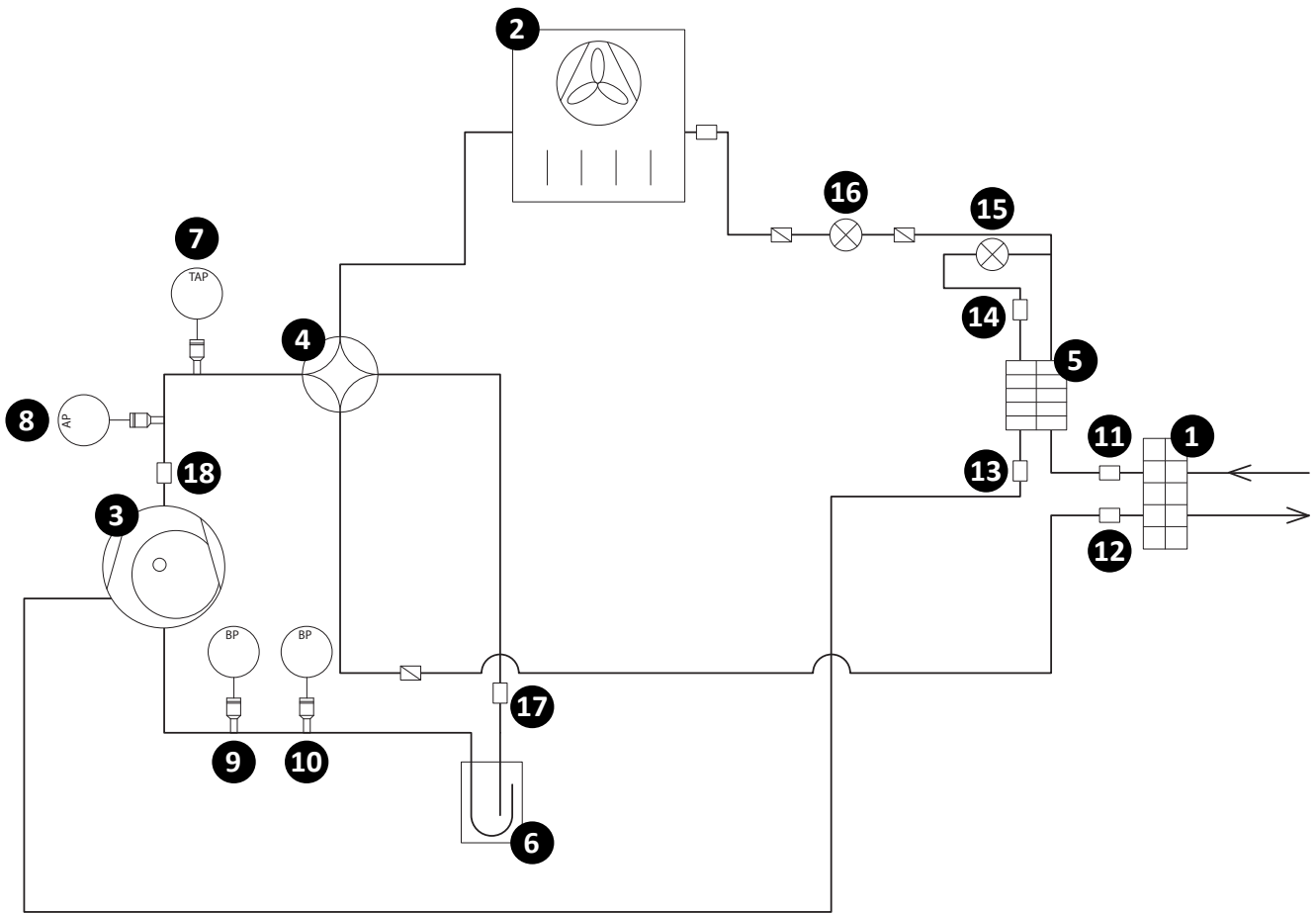

### COMPONENTS SUPPLIED AS STANDARD

1. Heat exchanger, service side
2. Heat exchanger, source side
3. Twin rotary DC inverter compressor
4. 4-way cycle reversing valve
5. Economiser
6. Fluid separator
7. High pressure transducer
8. High pressure switch
9. Low pressure switch (cooling)
10. Low pressure switch (heating)
11. Liquid temperature probe
12. Gas temperature probe
13. Economiser outlet temperature probe
14. Economiser inlet temperature probe
15. Electronic economiser expansion valve
16. Electronic expansion valve
17. Compressor intake temperature probe
18. Compressor delivery temperature probe

## ACCESSORIES

### HBI\_WT (220-240V ~ 50Hz)

### HBI\_WTT (380-415V ~3 50Hz)

Domestic hot water storage tank of 200, 300 litres with main coil and 3kW back-up electric heater:

- magnesium sacrificial anode
- stainless steel tank and coil
- painted sheet metal outer casing and insulation material, thickness 50mm
- internal installation

### HBI\_WTS (220-240V~50Hz)

### HBI\_WTST (380-415V ~3 50Hz)

Domestic hot water storage tank of 200, 300 litres with main coil, supplementary coil and 3kW back-up electric heater:

- magnesium sacrificial anode
- stainless steel tank and coil
- painted sheet metal outer casing and insulation material, thickness 50mm
- internal installation

### HMICB15

Connection cable for the control panel

Cable length 15m

HMI		040	060	080	100	120	140	160
HBI200	WT	.	.	.	.	.	.	.
	WTS	.	.	.	.	.	.	.
	WTT	.	.	.	.	.	.	.
	WTST	.	.	.	.	.	.	.
HBI300	WT	.	.	.	.	.	.	.
	WTS	.	.	.	.	.	.	.
	WTT	.	.	.	.	.	.	.
	WTST	.	.	.	.	.	.	.
HMICB15		.	.	.	.	.	.	

### HBI (ACCESSORIES)

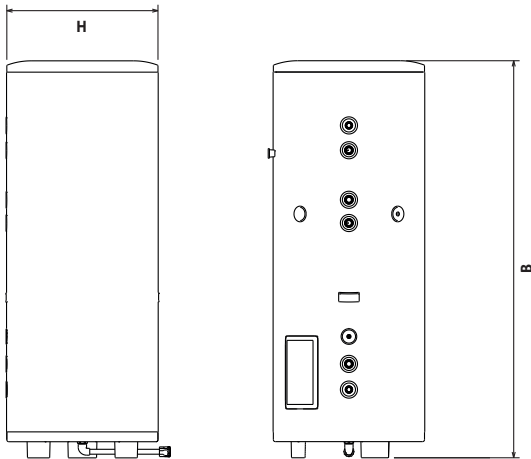

	A (mm)	B (mm)
HBI200WT	540	1595
HBI200WTS	540	1595
HBI300WT	620	1620
HBI300WTS	620	1620
HBI200WTT	540	1595
HBI200WTST	540	1595
HBI300WTT	620	1620
HBI300WTST	620	1620

# TECHNICAL PERFORMANCE DATA DECLARED EUROVENT - 14511:2013

## HMI (DATA 12/7 - 40/45°C)

HMI		040	060	080	100	120	140	160	100T	120T	140T	160T
<b>Performance in cooling mode 12°C / 7°C<sup>(1)</sup></b>												
Cooling capacity	kW	3,00	4,00	5,00	7,80	9,50	12,00	13,00	7,80	9,50	12,00	13,00
Input power	kW	0,94	1,29	1,61	2,48	3,20	4,14	4,96	2,64	3,11	4,38	4,91
Absorbed current	TO	4,30	5,90	7,37	11,35	14,65	18,95	22,70	4,01	4,73	6,65	7,46
EER	W/W	3,19	3,10	3,11	3,15	2,97	2,90	2,62	2,95	3,05	2,74	2,65
Water flow rate (services)	l/h	516	672	860	1320	1650	2080	2270	1270	1665	2065	2231
Useful head	kPa	75	74	74	71	65	51	45	71	64	51	46
<b>Performance in heating mode 40°C / 45°C<sup>(2)</sup></b>												
Heating capacity	kW	4,00	6,00	7,50	10,00	12,00	14,00	15,50	10,00	12,00	14,00	15,50
Input power	kW	1,00	1,58	2,00	2,70	3,48	4,18	4,70	2,70	3,48	4,18	4,70
Absorbed current	TO	4,58	7,23	9,15	12,36	15,93	19,13	21,51	4,10	5,29	6,35	7,14
COP	W/W	4,00	3,80	3,75	3,70	3,45	3,35	3,30	3,70	3,45	3,35	3,30
Water flow rate (services)	l/h	690	977	1240	1700	2050	2500	2700	1710	2040	2474	2734
Useful head	kPa	74	73	72	63	52	37	30	63	52	38	29

1 Data 14511:2013; Heat exchanger water (services side) 12°C / 7°C; Outside air 35°C.

2 Data 14511:2013; Heat exchanger water (services side) 40°C / 45°C; Outside air 7°C D.B. / 6°C W.B.

## HMI (DATA 23/18 - 30/35°C)

HMI		040	060	080	100	120	140	160	100T	120T	140T	160T
<b>Performance in cooling mode 23°C / 18°C<sup>(3)</sup></b>												
Cooling capacity	kW	3,80	5,80	6,80	8,80	11,00	12,50	14,50	8,80	11,00	12,50	14,50
Input power	kW	0,82	1,32	1,55	1,96	2,56	3,05	3,82	1,96	2,56	3,05	3,82
Absorbed current	TO	3,75	6,04	7,09	8,97	11,72	13,96	17,48	2,98	3,89	4,63	5,80
EER	W/W	4,63	4,39	4,39	4,49	4,30	4,10	3,80	4,49	4,30	4,10	3,80
Water flow rate (services)	l/h	660	981	1220	1510	1926	2238	2640	1500	1900	2200	2570
Useful head	kPa	74	73	72	69	56	46	32	69	57	47	34
<b>Performance in heating mode 30°C / 35°C<sup>(4)</sup></b>												
Heating capacity	kW	4,00	6,00	7,50	10,00	12,00	14,00	15,50	10,00	12,00	14,00	15,50
Input power	kW	0,79	1,20	1,63	2,17	2,64	3,22	3,60	2,17	2,64	3,22	3,60
Absorbed current	TO	3,62	5,49	7,46	9,93	12,08	14,74	16,48	3,30	4,01	4,89	5,47
COP	W/W	5,10	5,00	4,60	4,61	4,55	4,35	4,31	4,61	4,55	4,35	4,31
Water flow rate (services)	l/h	690	1030	1247	1736	2137	2524	2703	1720	2100	2400	2626
Useful head	kPa	74	73	72	62	49	36	30	62	50	40	32

3 Data 14511:2013; Heat exchanger water (services side) 23°C / 18°C; Outside air 35°C.

4 Data 14511:2013; Heat exchanger water (services side) 30°C / 35°C; Outside air 7°C D.B. / 6°C W.B.

HMI		040	060	080	100	120	140	160	100T	120T	140T	160T
<b>Performance in average ambient conditions (Average 35°C) - UE no.811/2013 Pdesignh ≤ 70kW</b>												
Pdesignh		5	5	6	9	11	11	13	9	11	11	13
ηs	%	185	185	183	176	175	168	164	176	175	168	164
Energy efficiency class		A+++	A+++	A+++	A+++	A+++	A++	A++	A+++	A+++	A++	A++
<b>Performance in average ambient conditions (Average 55°C) - UE no.811/2013 Pdesignh ≤ 70kW</b>												
Pdesignh		6	6	7	8	10	11	13	8	10	11	13
ηs	%	126	126	127	128	126	125	125	128	126	125	125
Energy efficiency class		A++	A++	A++	A++	A++	A++	A++	A++	A++	A++	A++

## TECHNICAL PERFORMANCE DATA - 14511:2018

### HMI (DATA 12/7 - 40/45°C)

HMI		040	060	080	100	120	140	160	100T	120T	140T	160T
<b>Performance in cooling mode 12°C / 7°C<sup>(1)</sup></b>												
Cooling capacity	kW	2.98	3.97	4.96	7.75	9.45	11.94	12.95	7.75	9.45	11.94	12.95
Input power	kW	0,94	1,29	1.61	2,48	3,20	4.14	4.96	2,64	3.11	4.38	4,91
Absorbed current	TO	4.70	6.40	7,90	12.00	15.00	20,00	23,00	4.60	5.30	7,30	8,10
EER	W/W	3,17	3.08	3.08	3,12	2.95	2,88	2.61	2.94	3,04	2.73	2,64
Water flow rate (services)	l/h	504	673	842	1318	1609	2038	2210	1318	1609	2038	2210
Useful head	kPa	74	74	74	69	64	52	47	69	64	52	47
<b>Performance in heating mode 40°C / 45°C<sup>(2)</sup></b>												
Heating capacity	kW	4,03	6.04	7,55	10,06	12.06	14,05	15.54	10,06	12.06	14,05	15.54
Input power	kW	1,00	1,58	2.00	2,70	3.48	4,18	4.70	2,70	3.48	4,18	4.70
Absorbed current	TO	5,00	7.80	9.70	13.00	17.00	20,00	22,00	4.70	5.90	6.90	7,70
COP	W/W	4,03	3,83	3,78	3.72	3.46	3,36	3.31	3.72	3.46	3,36	3.31
Water flow rate (services)	l/h	710	1062	1326	1762	2110	2456	2714	1762	2110	2456	2714
Useful head	kPa	74	73	71	60	50	39	29	60	50	39	29

1 Data 14511:2018; Heat exchanger water (services side) 12°C / 7°C; Outside air 35°C.

2 Data 14511:2018; Heat exchanger water (services side) 40°C / 45°C; Outside air 7°C D.B. / 6°C W.B.

### HMI (DATA 23/18 - 30/35°C)

HMI		040	060	080	100	120	140	160	100T	120T	140T	160T
<b>Performance in cooling mode 23°C / 18°C<sup>(3)</sup></b>												
Cooling capacity	kW	3.77	5.76	6.75	8.75	10.94	12.44	14.45	8.75	10.94	12.44	14.45
Input power	kW	0,82	1,32	1.55	1.96	2.56	3.05	3.82	1.96	2.56	3.05	3.82
Absorbed current	TO	4.20	6,60	7,60	9.50	12.00	15.00	18,00	3.60	4,50	5,20	6.40
EER	W/W	4.60	4.36	4.36	4.46	4,27	4,08	3,78	4.46	4,27	4,08	3,78
Water flow rate (services)	l/h	641	982	1152	1495	1873	2132	2478	1495	1873	2132	2478
Useful head	kPa	74	74	73	66	57	50	38	66	57	50	38
<b>Performance in heating mode 30°C / 35°C<sup>(4)</sup></b>												
Heating capacity	kW	4,03	6.04	7,55	10,06	12.06	14,05	15.54	10,06	12.06	14,05	15.54
Input power	kW	0,79	1.20	1.63	2.17	2,64	3.22	3.60	2.17	2,64	3.22	3.60
Absorbed current	TO	4.10	6,00	8.00	11,00	13.00	15.00	17.00	3.90	4.60	5,50	6.10
COP	W/W	5.10	5.04	4.63	4.63	4.57	4.36	4,32	4.63	4.57	4.36	4,32
Water flow rate (services)	l/h	708	1058	1321	1756	2102	2447	2704	1756	2102	2447	2704
Useful head	kPa	74	73	71	60	50	39	30	60	50	39	30

3 Data 14511:2018; Heat exchanger water (services side) 23°C / 18°C; Outside air 35°C.

4 Data 14511:2018; Heat exchanger water (services side) 30°C / 35°C; Outside air 7°C D.B. / 6°C W.B.

## GENERAL TECHNICAL DATA

HMI		040	060	080	100	120	140	160	100T	120T	140T	160T	
<b>Electric data</b>													
Power supply		220-240V ~ 50Hz							380-415V 3N ~ 50Hz				
Nominal input current <sup>(5)</sup>	TO	10,4	10,4	10,4	23,0	25,0	29,0	29,0	12,0	12,0	12,0	12,0	
<b>Compressors</b>													
Driver		Inverter											
Type		Twin-stage DC rotary inverter											
No. compressors	no.	1	1	1	1	1	1	1	1	1	1	1	
No. circuits	no.	1	1	1	1	1	1	1	1	1	1	1	
<b>Refrigerant:</b>													
Type		R32/ 675 kgCO <sub>2</sub> eq											
Refrigerant load	kg	0,9	0,9	0,9	2,2	2,2	2,2	2,2	2,2	2,2	2,2	2,2	
<b>Oil</b>													
Oil type		FW68DA											
Oil charge	l	0,5	0,5	0,5	1,1	1,1	1,1	1,1	1,1	1,1	1,1	1,1	
<b>Heat exchanger, service side</b>													
Type		Plates											
Quantity	no.	1											
Connection type		Female gas											
Connections (in/out)	ø	G1											
<b>Fans</b>													
Type		DC brushless axial flow fan											
Quantity	no.	1	1	1	1	1	1	1	1	1	1	1	
Air flow rate	m <sup>3</sup> /h	2600	2600	2600	4500	4500	4500	4500	4500	4500	4500	4500	
Useful static pressure	Pa												
<b>Sound data (in cooling mode)</b>													
Sound pressure 1m <sup>(7)</sup>	dB(A)	51	52	53	56	56	57	59	56	56	57	59	
<b>Sound data (in heating mode)</b>													
Sound power <sup>(6)</sup>	dB(A)	64	64	65	69	69	70	72	69	69	70	72	
Sound pressure 1m <sup>(7)</sup>	dB(A)	50	50	51	54	54	55	57	54	54	55	57	

5 The nominal input power (nominal input current) is the maximum electrical input power (maximum input current) to the system, in accordance with standards EN-60335-1 and EN-60335-2-40.

6 Sound power: Aermec determines the sound power value on the basis of measurements taken in accordance with standard UNI EN ISO 9614-2, in compliance with Eurovent certification.

7 Sound pressure measured in a semi-anechoic chamber at a distance of 1m from the external surface of the unit.

## DIMENSIONS - WEIGHTS - MINIMUM TECHNICAL CLEARANCES

HMI		040	060	080	100	120	140	160	100T	120T	140T	160T
<b>Dimensions</b>												
A	mm	1150	1150	1150	1200	1200	1200	1200	1200	1200	1200	1200
B	mm	345	345	345	460	460	460	460	460	460	460	460
C	mm	758	758	758	878	878	878	878	878	878	878	878
<b>Dimensions with packaging</b>												
A	mm	1260	1260	1260	1295	1295	1295	1295	1295	1295	1295	1295
B	mm	490	490	490	595	595	595	595	595	595	595	595
C	mm	900	900	900	1020	1020	1020	1020	1020	1020	1020	1020
<b>Minimum technical clearances</b>												
A1	mm	500	500	500	500	500	500	500	500	500	500	500
A2	mm	500	500	500	500	500	500	500	500	500	500	500
B1	mm	2000	2000	2000	2000	2000	2000	2000	2000	2000	2000	2000
B2	mm	500	500	500	500	500	500	500	500	500	500	500
C1	mm	1000	1000	1000	1000	1000	1000	1000	1000	1000	1000	1000
<b>Weights</b>												
Net weight	kg	96	96	96	151	151	151	151	151	151	151	151
Gross weight	kg	109	109	109	166	166	166	166	166	166	166	166

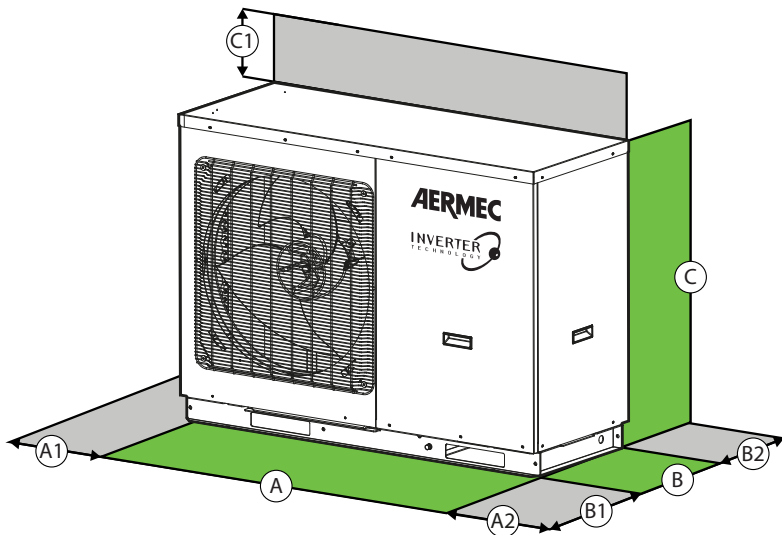

## REQUIREMENTS FOR INSTALLATION IN HARSH CLIMATES



Protect the outer unit from direct snow fall and ensure that the unit does NOT get buried in snow.

### WARNING:

1. During the installation stage, take into account any accumulations of snow by fitting appropriate shims on the base where the unit will be mounted.
2. Make sure that the snow NEVER builds up on the unit.
3. Include at least 300mm of clearance between the unit base and the floor and at least 100mm above the snow level.

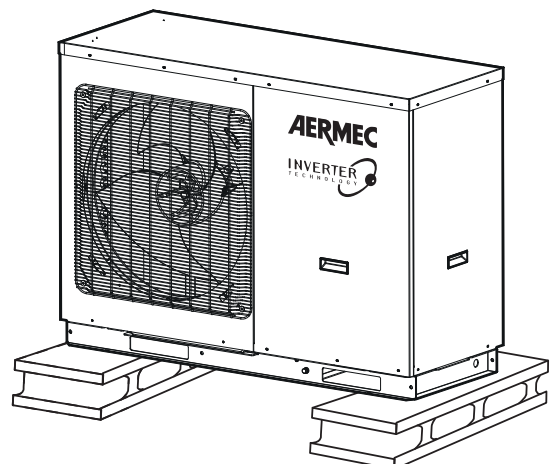

## OPERATING LIMITS

In their standard configuration, the units are not suitable for installation in salty environments.  
The values shown in the table relate to the min. and max. unit temperature limits.  
For more information, refer to the tables of output and intake values other than nominal, valid for  $\Delta T = 5^\circ\text{C}$ .

Contact our technical sales department if the unit needs to be used outside the operating limits.  
**NB: wind breaks should be used if the unit is installed in particularly windy areas, to prevent malfunctioning. Installation of windbreaks is recommended if wind speeds exceed 2.5 m/s.**

### COOLING MODE

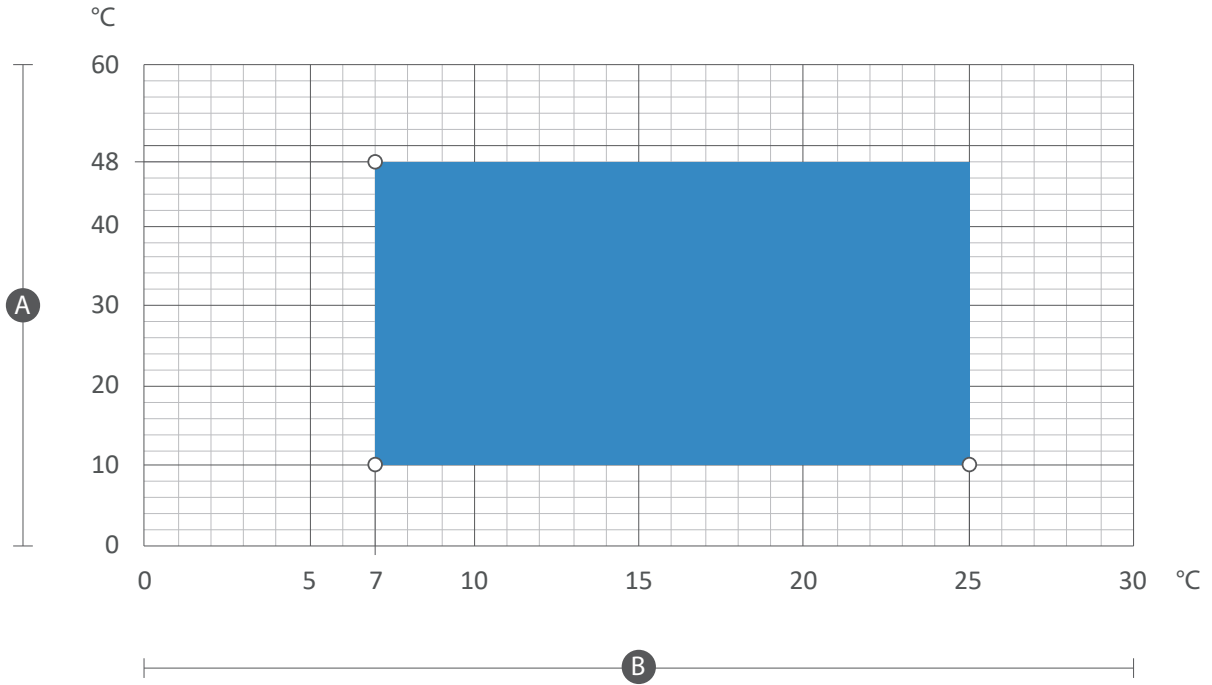

**Key**  
A Outside air temperature ( $^\circ\text{C}$ )  
B Processed water temperature ( $^\circ\text{C}$ )

### HEATING MODE

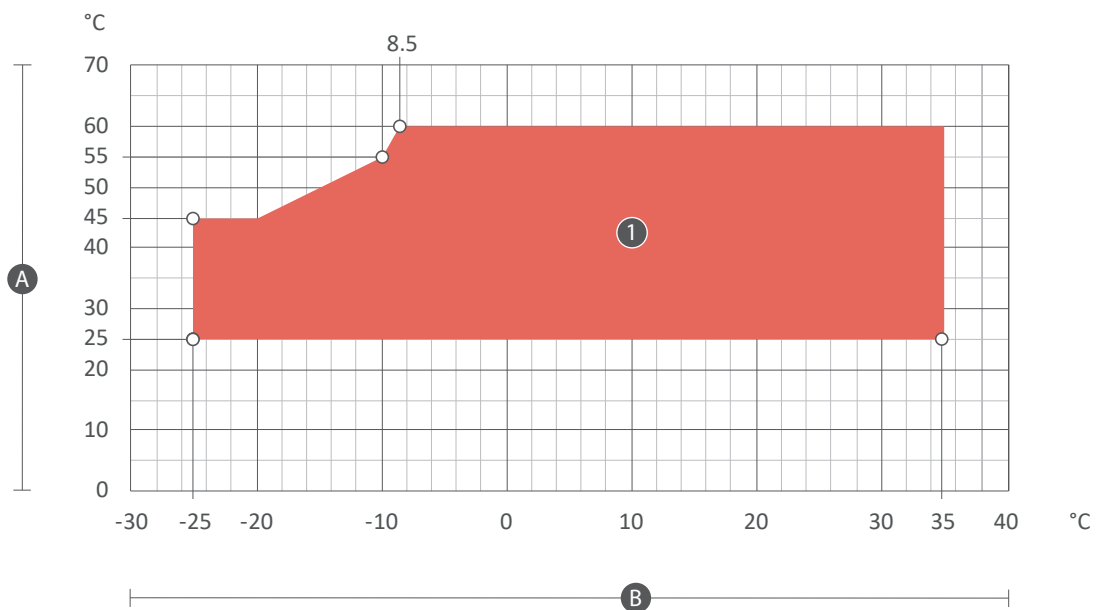

**Key**  
1 Heating mode  
A Processed water temperature ( $^\circ\text{C}$ )  
B Outside air temperature ( $^\circ\text{C}$ )

**DHW PRODUCTION**  
-25~45 $^\circ\text{C}$  outside air

# OUTPUTS AND INPUTS DIFFERENT FROM THE RATED VALUES

## COOLING MODE - 220-240V/1/50Hz

HMI040 - 220-240V/1/50Hz																		
TA D.B.	10	20	30	35	40	48	10	20	30	35	40	48	10	20	30	35	40	48
TWu	7						10						15					
Glycol	0	0	0	0	0	0	0	0	0	0	0	0	0	0	0	0	0	0
Pc	2,40	2,85	3,05	2,98	2,70	1,69	2,62	3,10	3,32	3,20	2,93	1,89	2,95	3,48	3,73	3,59	3,27	2,17
pe	0,57	0,71	0,87	0,94	1,03	1,16	0,55	0,68	0,83	0,91	0,99	1,12	0,51	0,65	0,79	0,86	0,94	1,06
EER	4,19	4,02	3,53	3,17	2,62	1,46	4,79	4,55	3,99	3,51	2,96	1,69	5,74	5,39	4,75	4,17	3,49	2,05
Qu	406	482	517	504	457	286	443	526	563	542	497	320	501	591	634	610	554	368
AP	74	74	74	74	74	74	74	74	74	74	74	74	74	74	74	74	74	74

HMI040 - 220-240V/1/50Hz																		
TA D.B.	10	20	30	35	40	48	10	20	30	35	40	48	10	20	30	35	40	48
TWu	18						20						25					
Glycol	0	0	0	0	0	0	0	0	0	0	0	0	0	0	0	0	0	0
Pc	3,13	3,69	3,95	3,77	3,44	2,31	3,24	3,81	4,09	3,93	3,54	2,40	3,47	4,07	4,37	4,20	3,75	2,56
pe	0,50	0,63	0,76	0,82	0,91	1,03	0,49	0,62	0,75	0,82	0,89	1,02	0,47	0,59	0,72	0,79	0,86	0,98
EER	6,32	5,89	5,19	4,60	3,78	2,24	6,66	6,18	5,46	4,78	3,96	2,36	7,44	6,85	6,07	5,3	4,35	2,61
Qu	531	627	673	641	584	392	550	648	696	669	602	407	591	694	746	717	640	435
AP	74	74	74	74	74	74	74	74	74	74	74	74	74	74	74	74	74	74

HMI060 - 220-240V/1/50Hz																		
TA D.B.	10	20	30	35	40	48	10	20	30	35	40	48	10	20	30	35	40	48
TWu	7						10						15					
Glycol	0	0	0	0	0	0	0	0	0	0	0	0	0	0	0	0	0	0
Pc	3,12	3,76	4,04	3,97	3,60	2,18	3,64	4,33	4,64	4,46	4,11	2,62	4,42	5,19	5,55	5,34	4,86	3,26
pe	0,77	0,97	1,19	1,29	1,42	1,61	0,78	0,98	1,20	1,32	1,43	1,62	0,79	0,99	1,21	1,33	1,45	1,64
EER	4,04	3,88	3,39	3,08	2,54	1,36	4,68	4,44	3,86	3,39	2,87	1,62	5,62	5,27	4,57	4,02	3,36	1,99
Qu	528	636	685	673	610	368	618	735	788	757	698	444	751	883	944	908	826	553
AP	74	74	75	74	74	74	74	74	74	74	74	74	74	74	74	74	74	74

HMI060 - 220-240V/1/50Hz																		
TA D.B.	10	20	30	35	40	48	10	20	30	35	40	48	10	20	30	35	40	48
TWu	18						20						25					
Glycol	0	0	0	0	0	0	0	0	0	0	0	0	0	0	0	0	0	0
Pc	4,82	5,63	6,03	5,76	5,24	3,57	5,06	5,90	6,33	6,09	5,47	3,75	5,57	6,46	6,96	6,70	5,94	4,12
pe	0,79	0,99	1,22	1,32	1,46	1,64	0,79	0,99	1,22	1,34	1,46	1,65	0,79	0,99	1,23	1,35	1,47	1,66
EER	6,12	5,7	4,95	4,36	3,6	2,17	6,42	5,96	5,17	4,55	3,74	2,28	7,03	6,5	5,66	4,98	4,04	2,48
Qu	821	960	1029	982	892	607	863	1007	1080	1039	932	639	951	1105	1191	1146	1015	702
AP	74	74	73	74	74	74	74	74	73	73	74	74	74	73	72	73	74	74

HMI080 - 220-240V/1/50Hz																		
TA D.B.	10	20	30	35	40	48	10	20	30	35	40	48	10	20	30	35	40	48
TWu	7						10						15					
Glycol	0	0	0	0	0	0	0	0	0	0	0	0	0	0	0	0	0	0
Pc	3,98	4,65	5,09	4,96	4,51	2,78	4,47	5,23	5,68	5,47	5,02	3,22	5,21	6,10	6,58	6,33	5,77	3,86
pe	0,97	1,20	1,49	1,61	1,77	2,00	0,95	1,19	1,47	1,61	1,75	1,98	0,94	1,18	1,45	1,59	1,73	1,95
EER	4,12	3,87	3,43	3,08	2,55	1,39	4,69	4,39	3,86	3,4	2,87	1,63	5,57	5,18	4,54	3,99	3,34	1,97
Qu	674	789	864	842	764	470	759	889	965	929	853	546	887	1039	1122	1079	982	655
AP	74	74	74	74	74	74	74	74	74	74	74	74	74	73	73	73	74	75

HMI080 - 220-240V/1/50Hz																		
TA D.B.	10	20	30	35	40	48	10	20	30	35	40	48	10	20	30	35	40	48
TWu	18						20						25					
Glycol	0	0	0	0	0	0	0	0	0	0	0	0	0	0	0	0	0	0
Pc	5,60	6,56	7,07	6,75	6,15	4,17	5,84	6,83	7,38	7,09	6,38	4,35	6,33	7,41	8,03	7,72	6,86	4,71
pe	0,93	1,17	1,44	1,55	1,71	1,94	0,92	1,16	1,43	1,57	1,71	1,93	0,91	1,15	1,42	1,55	1,69	1,92
EER	6,05	5,62	4,92	4,36	3,59	2,15	6,34	5,88	5,15	4,53	3,74	2,25	6,99	6,45	5,66	4,97	4,05	2,46
Qu	955	1119	1207	1152	1049	709	996	1166	1260	1211	1089	741	1082	1268	1374	1321	1173	804
AP	74	73	72	73	73	74	74	72	71	72	73	74	73	71	70	71	72	74

HMI100 - 220-240V/1/50Hz																		
TA D.B.	10	20	30	35	40	48	10	20	30	35	40	48	10	20	30	35	40	48
TWu	7						10						15					
Glycol	0	0	0	0	0	0	0	0	0	0	0	0	0	0	0	0	0	0
Pc	6,31	7,37	8,01	7,75	7,04	4,54	6,60	7,70	8,35	8,02	7,33	4,79	7,02	8,19	8,86	8,51	7,74	5,14
pe	1,50	1,86	2,32	2,48	2,72	3,03	1,40	1,74	2,15	2,30	2,54	2,85	1,24	1,58	1,93	2,06	2,28	2,58
EER	4,2	3,97	3,45	3,12	2,59	1,5	4,73	4,42	3,88	3,48	2,89	1,68	5,65	5,19	4,58	4,12	3,39	1,99
Qu	1073	1253	1363	1318	1197	770	1122	1311	1423	1366	1247	813	1196	1397	1513	1453	1320	875
AP	72	70	69	69	71	74	72	70	68	69	70	74	71	68	66	67	69	74

HMI100 - 220-240V/1/50Hz																		
TA D.B.	10	20	30	35	40	48	10	20	30	35	40	48	10	20	30	35	40	48
TWu	18						20						25					
Glycol	0	0	0	0	0	0	0	0	0	0	0	0	0	0	0	0	0	0
Pc	7,23	8,44	9,14	8,75	7,95	5,32	7,37	8,60	9,31	8,94	8,08	5,42	7,64	8,91	9,66	9,28	8,34	5,63
pe	1,17	1,50	1,84	1,96	2,16	2,45	1,12	1,45	1,78	1,90	2,08	2,37	1,04	1,35	1,68	1,78	1,93	2,22
EER	6,2	5,65	4,98	4,46	3,69	2,17	6,56	5,94	5,23	4,72	3,88	2,29	7,36	6,61	5,74	5,2	4,31	2,54
Qu	1235	1443	1562	1495	1358	906	1258	1470	1592	1528	1381	925	1307	1527	1656	1590	1429	961
AP	71	67	65	66	69	74	70	67	64	66	68	73	70	66	63	64	68	73

### Data 14511:2018

- TA D.B. Outside air temperature - dry bulb (°C)
  - TWu Water temperature - services side (°C)
  - Glycol % Minimum recommended percentage of ethylene glycol (%)
  - Pc Cooling capacity (kW)
  - Pe Input power (kW)
  - Qu Water flow rate - services side (l/h)
  - HP Useful head, net of pressure drops (kPa)
- Flow rates and useful head values calculated with ΔT 5°C*

### NB:

for operating conditions other than those stated, refer to the Magellano selection program, available at [www.aermec.com](http://www.aermec.com)

COOLING MODE - 220-240V/1/50Hz

HMI120 - 220-240V/1/50Hz																			
TA D.B.	10	20	30	35	40	48	10	20	30	35	40	48	10	20	30	35	40	48	
TWu	7						10						15						
Glycol	0	0	0	0	0	0	0	0	0	0	0	0	0	0	0	0	0	0	0
Pc	7.66	8.96	9.75	9.45	8.58	5.48	8,10	9,46	10,26	9,86	9,01	5,86	8,74	10,19	11,03	10,60	9,65	6,40	
pe	1.94	2.40	3.00	3.20	3.50	3.89	1.80	2.26	2.79	2.99	3.28	3.67	1.62	2.06	2.53	2.70	2.98	3.35	
EER	3.96	3.74	3.25	2.95	2.45	1.41	4.49	4.19	3.67	3.3	2.74	1,6	5,4	4,95	4,36	3,93	3,24	1,91	
Qu	1303	1525	1660	1609	1460	931	1379	1612	1750	1681	1536	996	1492	1741	1886	1812	1647	1091	
AP	70	66	63	64	67	73	68	64	61	62	66	73	66	61	57	59	63	72	

HMI120 - 220-240V/1/50Hz																		
TA D.B.	10	20	30	35	40	48	10	20	30	35	40	48	10	20	30	35	40	48
TWu	18						20						25					
Glycol	0	0	0	0	0	0	0	0	0	0	0	0	0	0	0	0	0	0
Pc	9,07	10,57	11,44	10,94	9,97	6,67	9,27	10,80	11,68	11,23	10,16	6,83	9,68	11,27	12,20	11,73	10,57	7,14
pe	1.53	1.96	2.41	2.56	2.83	3.19	1,47	1,90	2,35	2,49	2,74	3,10	1,37	1,79	2,23	2,36	2,57	2,92
EER	5.94	5.39	4.74	4.27	3.53	2.09	6.29	5.68	4.98	4.5	3.71	2,2	7,06	6,31	5,47	4,96	4,12	2,45
Qu	1550	1809	1958	1873	1705	1138	1585	1849	2001	1924	1739	1166	1658	1934	2095	2014	1813	1222
AP	65	59	55	57	62	72	65	58	54	56	61	71	63	56	51	53	59	71

HMI140 - 220-240V/1/50Hz																		
TA D.B.	10	20	30	35	40	48	10	20	30	35	40	48	10	20	30	35	40	48
TWu	7						10						15					
Glycol	0	0	0	0	0	0	0	0	0	0	0	0	0	0	0	0	0	0
Pc	9.83	11.42	12.43	11.94	10.86	7.11	9.92	11.57	12.57	12.08	10.99	7.23	10,08	11,81	12,81	12,30	11,19	7,40
pe	2.48	3.12	3.88	4.14	4.52	5.00	2.24	2.83	3.53	3.77	4.15	4.61	1,93	2,45	3,07	3,27	3,61	4,06
EER	3.96	3.66	3.2	2.88	2.4	1.42	4.42	4.08	3.56	3.21	2.65	1.57	5,21	4,81	4,17	3,76	3,1	1,82
Qu	1675	1948	2120	2038	1851	1208	1693	1976	2147	2063	1877	1230	1723	2020	2193	2105	1914	1261
AP	62	55	50	52	58	71	62	54	49	52	57	71	61	53	48	50	56	70

HMI140 - 220-240V/1/50Hz																		
TA D.B.	10	20	30	35	40	48	10	20	30	35	40	48	10	20	30	35	40	48
TWu	18						20						25					
Glycol	0	0	0	0	0	0	0	0	0	0	0	0	0	0	0	0	0	0
Pc	10.18	11.94	12.96	12.44	11.30	7.48	10.23	12.02	13.05	12.53	11.36	7.53	10,37	12,19	13,27	12,73	11,48	7,63
pe	1.79	2.28	2.86	3.05	3.34	3.78	1,72	2,18	2,74	2,91	3,19	3,61	1,58	2,00	2,53	2,67	2,88	3,28
EER	5.67	5.24	4.53	4.08	3.38	1.98	5.96	5.51	4.76	4.3	3.56	2.09	6,56	6,09	5,26	4,76	3,99	2,33
Qu	1741	2045	2221	2132	1933	1277	1752	2060	2239	2147	1945	1286	1777	2093	2280	2186	1971	1306
AP	61	52	47	50	56	70	61	52	46	49	55	70	60	51	45	48	54	70

HMI160 - 220-240V/1/50Hz																		
TA D.B.	10	20	30	35	40	48	10	20	30	35	40	48	10	20	30	35	40	48
TWu	7						10						15					
Glycol	0	0	0	0	0	0	0	0	0	0	0	0	0	0	0	0	0	0
Pc	10.55	12.31	13.39	12.95	11.77	7.60	10.98	12.82	13.91	13.37	12.21	7.98	11,64	13,58	14,70	14,12	12,86	8,53
pe	2.97	3.74	4.64	4.96	5.47	6.11	2.73	3.44	4.28	4.57	5.01	5.61	2,41	3,05	3,82	4,06	4,43	4,96
EER	3.55	3.29	2.89	2.61	2.15	1.24	4.03	3.72	3.25	2.93	2.44	1.42	4,82	4,45	3,85	3,48	2,9	1,72
Qu	1798	2101	2287	2210	2008	1292	1875	2191	2378	2285	2086	1359	1990	2326	2518	2420	2201	1456
AP	59	51	44	47	53	70	57	48	41	44	51	69	54	43	36	40	47	67

HMI160 - 230V																		
TA D.B.	10	20	30	35	40	48	10	20	30	35	40	48	10	20	30	35	40	48
TWu	18						20						25					
Glycol	0	0	0	0	0	0	0	0	0	0	0	0	0	0	0	0	0	0
Pc	11.98	13.97	15.12	14.45	13.19	8.80	12.18	14.21	15.38	14.78	13.39	8.96	12,60	14,70	15,92	15,31	13,80	9,28
pe	2.27	2.87	3.60	3.82	4.18	4.68	2.20	2.78	3.49	3.70	4.05	4.53	2,07	2,60	3,27	3,46	3,82	4,26
EER	5.27	4.86	4.2	3.78	3.15	1.88	5.54	5.12	4.41	4	3.31	1.98	6,09	5,65	4,86	4,42	3,61	2,18
Qu	2051	2396	2594	2478	2260	1504	2087	2439	2641	2537	2296	1533	2165	2528	2741	2634	2372	1590
AP	52	41	34	38	45	66	51	39	32	36	44	66	48	36	28	32	41	64

Data 14511:2018

- TA D.B. Outside air temperature - dry bulb (°C)
  - TWu Water temperature - services side (°C)
  - Glycol % Minimum recommended percentage of ethylene glycol (%)
  - Pc Cooling capacity (kW)
  - Pe Input power (kW)
  - Qu Water flow rate - services side (l/h)
  - HP Useful head, net of pressure drops (kPa)
- Flow rates and useful head values calculated with  $\Delta T$  5°C

**NB:**  
for operating conditions other than those stated, refer to the Magellano selection program, available at [www.aermec.com](http://www.aermec.com)

COOLING MODE - 380-415V/3N/50Hz

HMI100T - 380-415V/3N/50Hz																		
TA D.B.	10	20	30	35	40	48	10	20	30	35	40	48	10	20	30	35	40	48
TWu	7						10						15					
Glycol	0	0	0	0	0	0	0	0	0	0	0	0	0	0	0	0	0	0
Pc	6.31	7.37	8.01	7.75	7.04	4.54	6.60	7.70	8.35	8.02	7.33	4.79	7.02	8.19	8.86	8.51	7.74	5.14
pe	1.58	1.98	2.46	2.64	2.91	3.28	1.44	1.81	2.25	2.40	2.65	2.99	1.25	1.58	1.98	2.11	2.31	2.62
EER	4.00	3.72	3.26	2.94	2.42	1.39	4.59	4.26	3.71	3.34	2.77	1.60	5.60	5.18	4.49	4.04	3.35	1.96
Qu	1073	1253	1363	1318	1197	770	1122	1311	1423	1366	1247	813	1196	1397	1513	1453	1320	875
AP	72	70	69	69	71	74	72	70	68	69	70	74	71	68	66	67	69	74

HMI100T - 380-415V/3N/50Hz																		
TA D.B.	10	20	30	35	40	48	10	20	30	35	40	48	10	20	30	35	40	48
TWu	18						20						25					
Glycol	0	0	0	0	0	0	0	0	0	0	0	0	0	0	0	0	0	0
Pc	7.23	8.44	9.14	8.75	7.95	5.32	7.37	8.60	9.31	8.94	8.08	5.42	7.64	8.91	9.66	9.28	8.34	5.63
pe	1.17	1.47	1.85	1.96	2.16	2.45	1.13	1.42	1.78	1.89	2.08	2.36	1.05	1.31	1.65	1.75	1.94	2.21
EER	6.18	5.73	4.94	4.46	3.68	2.17	6.55	6.07	5.23	4.72	3.88	2.29	7.30	6.79	5.85	5.30	4.29	2.55
Qu	1235	1443	1562	1495	1358	906	1258	1470	1592	1528	1381	925	1307	1527	1656	1590	1429	961
AP	71	67	65	66	69	74	70	67	64	66	68	73	70	66	63	64	68	73

HMI120T - 380-415V/3N/50Hz																		
TA D.B.	10	20	30	35	40	48	10	20	30	35	40	48	10	20	30	35	40	48
TWu	7						10						15					
Glycol	0	0	0	0	0	0	0	0	0	0	0	0	0	0	0	0	0	0
Pc	7.66	8.96	9.75	9.45	8.58	5.48	8.10	9.46	10.26	9.86	9.01	5.86	8.74	10.19	11.03	10.60	9.65	6.40
pe	1.86	2.35	2.91	3.11	3.44	3.88	1.74	2.20	2.74	2.93	3.21	3.62	1.59	2.00	2.51	2.67	2.93	3.30
EER	4.11	3.80	3.34	3.04	2.49	1.41	4.65	4.30	3.75	3.37	2.81	1.62	5.50	5.09	4.40	3.96	3.29	1.94
Qu	1303	1525	1660	1609	1460	931	1379	1612	1750	1681	1536	996	1492	1741	1886	1812	1647	1091
AP	70	66	63	64	67	73	68	64	61	62	66	73	66	61	57	59	63	72

HMI120T - 380-415V/3N/50Hz																		
TA D.B.	10	20	30	35	40	48	10	20	30	35	40	48	10	20	30	35	40	48
TWu	18						20						25					
Glycol	0	0	0	0	0	0	0	0	0	0	0	0	0	0	0	0	0	0
Pc	9.07	10.57	11.44	10.94	9.97	6.67	9.27	10.80	11.68	11.23	10.16	6.83	9.68	11.27	12.20	11.73	10.57	7.14
pe	1.52	1.92	2.41	2.56	2.81	3.16	1.49	1.87	2.35	2.50	2.75	3.09	1.43	1.79	2.26	2.39	2.65	2.97
EER	5.95	5.52	4.75	4.27	3.55	2.11	6.22	5.77	4.96	4.49	3.70	2.21	6.75	6.29	5.40	4.91	3.98	2.40
Qu	1550	1809	1958	1873	1705	1138	1585	1849	2001	1924	1739	1166	1658	1934	2095	2014	1813	1222
AP	65	59	55	57	62	72	65	58	54	56	61	71	63	56	51	53	59	71

HMI140T - 380-415V/3N/50Hz																		
TA D.B.	10	20	30	35	40	48	10	20	30	35	40	48	10	20	30	35	40	48
TWu	7						10						15					
Glycol	0	0	0	0	0	0	0	0	0	0	0	0	0	0	0	0	0	0
Pc	9.83	11.42	12.43	11.94	10.86	7.11	9.92	11.57	12.57	12.08	10.99	7.23	10.08	11.81	12.81	12.30	11.19	7.40
pe	2.62	3.28	4.08	4.38	4.81	5.37	2.33	2.94	3.67	3.91	4.30	4.81	1.96	2.49	3.12	3.32	3.63	4.08
EER	3.76	3.49	3.05	2.73	2.26	1.32	4.25	3.94	3.42	3.09	2.56	1.50	5.14	4.74	4.11	3.71	3.08	1.81
Qu	1675	1948	2120	2038	1851	1208	1693	1976	2147	2063	1877	1230	1723	2020	2193	2105	1914	1261
AP	62	55	50	52	58	71	62	54	49	52	57	71	61	53	48	50	56	70

HMI140T - 380-415V/3N/50Hz																		
TA D.B.	10	20	30	35	40	48	10	20	30	35	40	48	10	20	30	35	40	48
TWu	18						20						25					
Glycol	0	0	0	0	0	0	0	0	0	0	0	0	0	0	0	0	0	0
Pc	10.18	11.94	12.96	12.44	11.30	7.48	10.23	12.02	13.05	12.53	11.36	7.53	10.37	12.19	13.27	12.73	11.48	7.63
pe	1.79	2.28	2.87	3.05	3.33	3.75	1.70	2.17	2.72	2.89	3.17	3.57	1.53	1.95	2.46	2.60	2.87	3.24
EER	5.67	5.23	4.52	4.08	3.39	2.00	6.02	5.55	4.79	4.34	3.59	2.11	6.77	6.25	5.40	4.90	4.00	2.36
Qu	1741	2045	2221	2132	1933	1277	1752	2060	2239	2147	1945	1286	1777	2093	2280	2186	1971	1306
AP	61	52	47	50	56	70	61	52	46	49	55	70	60	51	45	48	54	70

HMI160T - 380-415V/3N/50Hz																		
TA D.B.	10	20	30	35	40	48	10	20	30	35	40	48	10	20	30	35	40	48
TWu	7						10						15					
Glycol	0	0	0	0	0	0	0	0	0	0	0	0	0	0	0	0	0	0
Pc	10.55	12.31	13.39	12.95	11.77	7.60	10.98	12.82	13.91	13.37	12.21	7.98	11.64	13.58	14.70	14.12	12.86	8.53
pe	2.94	3.71	4.60	4.91	5.42	6.06	2.70	3.42	4.25	4.54	4.98	5.57	2.40	3.04	3.80	4.04	4.42	4.94
EER	3.59	3.32	2.91	2.64	2.17	1.25	4.06	3.75	3.27	2.95	2.45	1.43	4.85	4.47	3.87	3.49	2.91	1.73
Qu	1798	2101	2287	2210	2008	1292	1875	2191	2378	2285	2086	1359	1990	2326	2518	2420	2201	1456
AP	59	51	44	47	53	70	57	48	41	44	51	69	54	43	36	40	47	67

HMI160T - 380-415V/3N/50Hz																		
TA D.B.	10	20	30	35	40	48	10	20	30	35	40	48	10	20	30	35	40	48
TWu	18						20						25					
Glycol	0	0	0	0	0	0	0	0	0	0	0	0	0	0	0	0	0	0
Pc	11.98	13.97	15.12	14.45	13.19	8.80	12.18	14.21	15.38	14.78	13.39	8.96	12.60	14.70	15.92	15.31	13.80	9.28
pe	2.27	2.86	3.59	3.82	4.18	4.67	2.20	2.77	3.48	3.69	4.05	4.52	2.07	2.60	3.28	3.47	3.83	4.27
EER	5.28	4.88	4.21	3.78	3.16	1.89	5.55	5.13	4.42	4.00	3.31	1.98	6.09	5.65	4.86	4.42	3.60	2.18
Qu	2051	2396	2594	2478	2260	1504	2087	2439	2641	2537	2296	1533	2165	2528	2741	2634	2372	1590
AP	52	41	34	38	45	66	51	39	32	36	44	66	48	36	28	32	41	64

Data 14511:2018

- TA D.B. Outside air temperature - dry bulb (°C)
  - TWu Water temperature - services side (°C)
  - Glycol % Minimum recommended percentage of ethylene glycol (%)
  - Pc Cooling capacity (kW)
  - Pe Input power (kW)
  - Qu Water flow rate - services side (l/h)
  - HP Useful head, net of pressure drops (kPa)
- Flow rates and useful head values calculated with  $\Delta T$  5°C

NB:

for operating conditions other than those stated, refer to the Magellano selection program, available at [www.aermec.com](http://www.aermec.com)

HEATING MODE - 220-240V/1/50Hz

HMI040 - 220-240V/1/50Hz																		
TA D.B.	-25	-10	0	7	20	35	-25	-10	0	7	20	35	-25	-10	0	7	20	35
TWu	25						35						45					
Glycol	0	0	0	0	0	0	0	0	0	0	0	0	-	0	0	0	0	0
PH	1,74	2,86	3,56	3,86	3,98	2,43	1,66	2,67	3,29	4,03	4,25	2,72	-	2,58	3,19	4,03	4,26	2,73
pe	0,43	0,59	0,68	0,64	0,56	0,30	0,58	0,74	0,80	0,79	0,72	0,39	-	0,89	0,99	1,00	0,88	0,47
EER	4,02	4,86	5,24	6,04	7,09	8,07	2,85	3,60	4,13	5,10	5,89	7,08	-	2,90	3,23	4,03	4,82	5,84
Qu	306	501	622	675	696	426	293	469	578	708	745	479	-	456	563	710	749	482
AP	74	74	74	75	74	74	74	74	74	74	74	74	-	74	74	74	74	74

HMI040 - 220-240V/1/50Hz																		
TA D.B.	-25	-10	0	7	20	35	-25	-10	0	7	20	35	-25	-10	0	7	20	35
TWu	50						55						60					
Glycol	-	0	0	0	0	0	-	0	0	0	0	0	-	-	0	0	0	0
PH	-	2,52	3,12	3,84	4,17	2,62	-	2,41	3,00	3,67	4,01	2,45	-	-	2,78	3,45	3,80	2,21
pe	-	0,97	1,10	1,08	0,97	0,51	-	1,07	1,20	1,18	1,06	0,56	-	-	1,29	1,29	1,16	0,62
EER	-	2,59	2,85	3,56	4,30	5,12	-	2,25	2,50	3,11	3,79	4,36	-	-	2,15	2,67	3,28	3,57
Qu	-	445	552	678	735	464	-	427	531	650	710	434	-	-	493	613	674	393
AP	-	74	74	74	74	74	-	74	74	74	74	74	-	-	74	74	74	74

HMI060 - 220-240V/1/50Hz																		
TA D.B.	-25	-10	0	7	20	35	-25	-10	0	7	20	35	-25	-10	0	7	20	35
TWu	25						35						45					
Glycol	0	0	0	0	0	0	0	0	0	0	0	0	-	0	0	0	0	0
PH	2,65	4,27	5,34	5,77	5,97	3,66	2,45	3,94	5,03	6,04	6,36	4,09	-	3,86	4,81	6,04	6,37	4,09
pe	0,65	0,92	1,06	1,00	0,88	0,47	0,91	1,17	1,28	1,20	1,14	0,60	-	1,40	1,54	1,58	1,39	0,73
EER	4,09	4,62	5,06	5,76	6,75	7,75	2,68	3,38	3,93	5,04	5,60	6,77	-	2,75	3,11	3,83	4,58	5,60
Qu	465	747	932	1008	1042	640	431	692	882	1058	1114	718	-	680	846	1062	1120	721
AP	74	74	74	74	73	74	74	75	74	73	73	74	-	75	74	73	73	74

HMI060 - 220-240V/1/50Hz																		
TA D.B.	-25	-10	0	7	20	35	-25	-10	0	7	20	35	-25	-10	0	7	20	35
TWu	50						55						60					
Glycol	-	0	0	0	0	0	-	0	0	0	0	0	-	-	0	0	0	0
PH	-	3,79	4,68	5,75	6,24	3,93	-	3,62	4,53	5,50	6,02	3,68	-	-	4,33	5,18	5,70	3,32
pe	-	1,54	1,69	1,70	1,53	0,80	-	1,68	1,85	1,86	1,67	0,88	-	-	2,02	2,04	1,84	0,97
EER	-	2,47	2,77	3,38	4,08	4,90	-	2,15	2,45	2,95	3,59	4,17	-	-	2,15	2,53	3,11	3,41
Qu	-	669	826	1013	1099	695	-	641	800	971	1061	650	-	-	767	916	1009	588
AP	-	74	74	74	73	74	-	74	74	74	73	74	-	-	74	74	74	74

HMI080 - 220-240V/1/50Hz																		
TA D.B.	-25	-10	0	7	20	35	-25	-10	0	7	20	35	-25	-10	0	7	20	35
TWu	25						35						45					
Glycol	0	0	0	0	0	0	0	0	0	0	0	0	-	0	0	0	0	0
PH	3,26	5,35	6,66	7,22	7,45	4,55	3,11	4,99	6,16	7,55	7,95	5,10	-	4,83	5,98	7,55	7,97	5,11
pe	0,85	1,17	1,35	1,28	1,12	0,59	1,15	1,47	1,59	1,63	1,44	0,76	-	1,77	1,97	2,00	1,77	0,93
EER	3,84	4,59	4,92	5,66	6,65	7,71	2,71	3,40	3,88	4,63	5,51	6,70	-	2,74	3,03	3,78	4,51	5,53
Qu	571	935	1161	1259	1299	795	547	875	1079	1321	1391	894	-	851	1051	1326	1399	899
AP	74	74	72	71	71	74	74	74	73	71	70	74	-	74	73	71	70	74

HMI080 - 220-240V/1/50Hz																		
TA D.B.	-25	-10	0	7	20	35	-25	-10	0	7	20	35	-25	-10	0	7	20	35
TWu	50						55						60					
Glycol	-	0	0	0	0	0	-	0	0	0	0	0	-	-	0	0	0	0
Pc	-	4,71	5,85	7,20	7,80	4,92	-	4,51	5,61	6,88	7,52	4,59	-	-	5,20	6,47	7,12	4,14
pe	-	1,93	2,18	2,16	1,94	1,01	-	2,12	2,39	2,36	2,12	1,11	-	-	2,58	2,58	2,32	1,22
EER	-	2,44	2,68	3,34	4,03	4,85	-	2,12	2,35	2,92	3,55	4,13	-	-	2,02	2,51	3,07	3,38
Qu	-	831	1030	1266	1372	867	-	797	990	1214	1325	811	-	-	921	1143	1258	733
AP	-	74	73	71	70	74	-	74	74	72	71	74	-	-	74	73	71	74

HMI100 - 220-240V/1/50Hz																		
TA D.B.	-25	-10	0	7	20	35	-25	-10	0	7	20	35	-25	-10	0	7	20	35
TWu	25						35						45					
Glycol	0	0	0	0	0	0	0	0	0	0	0	0	-	0	0	0	0	0
PH	4,26	7,01	8,86	9,73	10,37	5,95	4,13	6,72	8,50	10,06	10,58	6,41	-	6,39	8,06	10,06	10,71	6,77
pe	1,15	1,57	1,80	1,73	1,51	0,80	1,55	1,97	2,14	2,17	1,95	1,03	-	2,37	2,60	2,70	2,39	1,25
EER	3,71	4,45	4,93	5,62	6,85	7,42	2,67	3,42	3,97	4,63	5,42	6,20	-	2,70	3,10	3,72	4,49	5,41
Qu	745	1222	1542	1693	1804	1038	725	1177	1486	1756	1847	1122	-	1123	1414	1762	1876	1190
AP	74	71	65	62	59	73	74	71	67	60	58	72	-	72	68	60	57	71

HMI100 - 220-240V/1/50Hz																		
TA D.B.	-25	-10	0	7	20	35	-25	-10	0	7	20	35	-25	-10	0	7	20	35
TWu	50						55						60					
Glycol	-	0	0	0	0	0	-	0	0	0	0	0	-	-	0	0	0	0
PH	-	6,21	7,80	9,77	10,53	6,70	-	6,01	7,52	9,30	10,06	6,34	0	0	7,22	8,45	9,22	5,60
pe	-	2,60	2,85	2,91	2,62	1,37	-	2,86	3,13	3,18	2,86	1,50	0	0	3,41	3,48	3,13	1,65
EER	-	2,39	2,73	3,35	4,02	4,90	-	2,11	2,41	2,92	3,52	4,23	0	0	2,12	2,43	2,95	3,40
Qu	-	1093	1372	1716	1848	1179	-	1061	1326	1636	1770	1118	0	0	1276	1491	1626	990
AP	-	72	69	61	58	71	-	72	69	63	60	72	0	0	70	66	64	73

Data 14511:2018

- TA D.B. Outside air temperature - dry bulb (°C)
  - TWu Water temperature - services side (°C)
  - Glycol % Minimum recommended percentage of ethylene glycol (%)
  - Ph Heating capacity (kW)
  - Pe Input power (kW)
  - Qu Water flow rate - services side (l/h)
  - HP Useful head, net of pressure drops (kPa)
- Flow rates and useful head values calculated with  $\Delta T 5^\circ C$

**NB:**  
for operating conditions other than those stated, refer to the Magellano selection program, available at [www.aermec.com](http://www.aermec.com)

HEATING MODE - 220-240V/1/50Hz

HMI120 - 220-240V/1/50Hz																		
TA D.B.	-25	-10	0	7	20	35	-25	-10	0	7	20	35	-25	-10	0	7	20	35
TWu	25						35						45					
Glycol	0	0	0	0	0	0	0	0	0	0	0	0	-	0	0	0	0	0
Pc	5.25	8.47	10.58	11.53	11.99	7.12	4.88	7.87	10.08	12.06	12.77	8.09	-	7.72	9.66	12.06	12.77	8.15
pe	1.41	2.02	2.32	2.22	1.96	1.03	1.97	2.53	2.79	2.64	2.52	1.32	-	3.05	3.36	3.48	3.08	1.60
EER	3.72	4.18	4.56	5.20	6.12	6.92	2.48	3.10	3.62	4.57	5.06	6.11	-	2.54	2.88	3.46	4.15	5.08
Qu	917	1475	1841	2003	2084	1241	855	1376	1759	2102	2226	1414	-	1355	1693	2110	2234	1430
AP	73	67	58	54	51	71	74	69	60	50	46	68	-	69	62	50	46	68

HMI120 - 220-240V/1/50Hz																		
TA D.B.	-25	-10	0	7	20	35	-25	-10	0	7	20	35	-25	-10	0	7	20	35
TWu	50						55						60					
Glycol	-	0	0	0	0	0	-	0	0	0	0	0	-	-	0	0	0	0
Pc	-	7.57	9.40	11.51	12.49	7.85	-	7.23	9.07	11.02	12.01	7.33	-	-	8.63	10.37	11.35	6.59
pe	-	3.33	3.68	3.74	3.38	1.75	-	3.65	4.03	4.09	3.69	1.92	-	-	4.40	4.47	4.03	2.11
EER	-	2.27	2.56	3.08	3.70	4.48	-	1.98	2.25	2.69	3.26	3.82	-	-	1.96	2.32	2.82	3.12
Qu	-	1331	1651	2019	2189	1380	-	1274	1596	1937	2110	1292	-	-	1522	1827	1999	1165
AP	-	69	63	53	48	68	-	70	64	56	50	70	-	-	66	59	54	71

HMI140 - 220-240V/1/50Hz																		
TA D.B.	-25	-10	0	7	20	35	-25	-10	0	7	20	35	-25	-10	0	7	20	35
TWu	25						35						45					
Glycol	0	0	0	0	0	0	0	0	0	0	0	0	-	0	0	0	0	0
Pc	6.12	9.87	12.33	13.43	13.98	8.29	5.68	9.16	11.74	14.05	14.89	9.42	-	8.99	11.25	14.05	14.89	9.50
pe	1.69	2.43	2.79	2.67	2.37	1.23	2.35	3.03	3.34	3.22	3.04	1.59	-	3.64	4.02	4.18	3.71	1.92
EER	3.63	4.07	4.42	5.03	5.91	6.73	2.42	3.02	3.51	4.36	4.89	5.93	-	2.47	2.80	3.36	4.01	4.94
Qu	1068	1717	2143	2332	2426	1444	996	1601	2048	2447	2591	1645	-	1577	1970	2456	2601	1664
AP	72	61	49	43	40	67	73	64	52	39	34	63	-	65	55	39	33	63

HMI140 - 220-240V/1/50Hz																		
TA D.B.	-25	-10	0	7	20	35	-25	-10	0	7	20	35	-25	-10	0	7	20	35
TWu	50						55						60					
Glycol	-	0	0	0	0	0	-	0	0	0	0	0	-	-	0	0	0	0
Pc	-	8.82	10.95	13.42	14.56	9.14	-	8.42	10.56	12.84	14.00	8.54	-	-	10.05	12.08	13.23	7.68
pe	-	3.98	4.41	4.49	4.06	2.10	-	4.36	4.82	4.91	4.43	2.30	-	-	5.27	5.36	4.83	2.52
EER	-	2.21	2.49	2.99	3.59	4.35	-	1.93	2.19	2.62	3.16	3.71	-	-	1.91	2.26	2.74	3.04
Qu	-	1549	1921	2350	2547	1606	-	1483	1857	2254	2456	1503	-	-	1772	2126	2326	1356
AP	-	65	56	42	35	64	-	67	58	45	39	66	-	-	60	50	43	69

HMI160 - 220-240V/1/50Hz																		
TA D.B.	-25	-10	0	7	20	35	-25	-10	0	7	20	35	-25	-10	0	7	20	35
TWu	25						35						45					
Glycol	0	0	0	0	0	0	0	0	0	0	0	0	-	0	0	0	0	0
Pc	6.76	10.91	13.64	14.86	15.46	9.17	6.28	10.13	12.99	15.54	16.47	10.42	-	9.95	12.45	15.54	16.47	10.50
pe	1.89	2.72	3.14	3.00	2.67	1.38	2.63	3.40	3.75	3.60	3.43	1.78	-	4.08	4.51	4.70	4.18	2.16
EER	3.58	4.01	4.35	4.95	5.80	6.63	2.39	2.98	3.46	4.32	4.80	5.84	-	2.44	2.76	3.31	3.94	4.87
Qu	1180	1898	2368	2577	2681	1596	1100	1769	2263	2704	2864	1818	-	1743	2177	2714	2874	1839
AP	71	57	42	34	30	64	72	60	45	30	24	59	-	61	48	29	24	58

HMI160 - 230V																		
TA D.B.	-25	-10	0	7	20	35	-25	-10	0	7	20	35	-25	-10	0	7	20	35
TWu	50						55						60					
Glycol	-	0	0	0	0	0	-	0	0	0	0	0	-	-	0	0	0	0
Pc	-	9.75	12.11	14.84	16.10	10.11	-	9.31	11.68	14.20	15.49	9.44	-	-	11.12	13.36	14.63	8.49
pe	-	4.46	4.94	5.05	4.57	2.36	-	4.89	5.40	5.51	4.98	2.58	-	-	5.90	6.01	5.42	2.83
EER	-	2.18	2.45	2.94	3.53	4.29	-	1.90	2.16	2.58	3.11	3.66	-	-	1.88	2.22	2.70	3.00
Qu	-	1712	2123	2597	2815	1775	-	1639	2053	2491	2714	1661	-	-	1958	2350	2571	1498
AP	-	62	50	34	26	60	-	63	52	37	29	63	-	-	55	42	34	66

Data 14511:2018

- TA D.B. Outside air temperature - dry bulb (°C)
  - TWu Water temperature - services side (°C)
  - Glycol % Minimum recommended percentage of ethylene glycol (%)
  - Ph Heating capacity (kW)
  - Pe Input power (kW)
  - Qu Water flow rate - services side (l/h)
  - HP Useful head, net of pressure drops (kPa)
- Flow rates and useful head values calculated with  $\Delta T$  5°C

**NB:**  
for operating conditions other than those stated, refer to the Magellano selection program, available at [www.aermec.com](http://www.aermec.com)

HEATING MODE - 380-415V/3N/50Hz

HMI100T - 380-415V/3N/50Hz																		
TA D.B.	-25	-10	0	7	20	35	-25	-10	0	7	20	35	-25	-10	0	7	20	35
TWu	25						35						45					
Glycol	0	0	0	0	0	0	0	0	0	0	0	0	-	0	0	0	0	0
PH	4.38	7.07	8.83	9.61	10,00	5.94	4,07	6.56	8.41	10,06	10,66	6.75	-	6.44	8.06	10,06	10,66	6.80
pe	1.15	1.57	1.80	1.73	1.52	0,79	1,55	1.97	2,16	2,17	1.96	1,03	-	2,37	2.61	2,70	2,39	1.25
EER	3.83	4.50	4.90	5.57	6.59	7.49	2.63	3.33	3.88	4.63	5.45	6.58	-	2.72	3.09	3.72	4.46	5.46
Qu	766	1232	1538	1673	1741	1036	714	1149	1469	1756	1860	1181	-	1132	1414	1762	1866	1194
AP	74	71	66	63	61	73	74	72	67	60	58	71	-	72	68	60	58	71

HMI100T - 380-415V/3N/50Hz																		
TA D.B.	-25	-10	0	7	20	35	-25	-10	0	7	20	35	-25	-10	0	7	20	35
TWu	50						55						60					
Glycol	-	0	0	0	0	0	-	0	0	0	0	0	-	-	0	0	0	0
Pc	-	6.31	7.84	9.60	10.42	6.55	-	6.03	7.56	9.19	10.02	6.11	-	-	7.20	8.65	9.47	5.50
pe	-	2.59	2.86	2.91	2.62	1.36	-	2.85	3.13	3.18	2.86	1.49	-	-	3.43	3.47	3.13	1.64
EER	-	2.43	2.74	3.30	3.98	4.80	-	2.12	2.41	2.89	3.50	4.10	-	-	2.10	2.49	3.03	3.35
Qu	-	1112	1379	1686	1828	1153	-	1064	1333	1618	1762	1079	-	-	1271	1526	1669	973
AP	-	72	68	62	59	72	-	72	69	64	60	72	-	-	70	66	63	73

HMI120T - 380-415V/3N/50Hz																		
TA D.B.	-25	-10	0	7	20	35	-25	-10	0	7	20	35	-25	-10	0	7	20	35
TWu	25						35						45					
Glycol	0	0	0	0	0	0	0	0	0	0	0	0	-	0	0	0	0	0
PH	5.25	8.47	10.44	11.29	11.87	7.12	4.88	7.87	10.10	12.06	12.77	8.14	-	7.72	9.75	12.06	12.81	8.18
pe	1.41	2.02	2.29	2.19	1.95	1.03	1.97	2.53	2.79	2.64	2.52	1.33	-	3.05	3.36	3.48	3.09	1.61
EER	3.72	4.18	4.56	5.16	6.10	6.91	2.48	3.10	3.63	4.57	5.06	6.12	-	2.54	2.90	3.46	4.15	5.10
Qu	917	1475	1816	1963	2063	1241	855	1376	1764	2102	2225	1423	-	1355	1708	2110	2241	1436
AP	73	67	59	55	52	71	74	69	60	50	46	68	-	69	62	50	46	67

HMI120T - 380-415V/3N/50Hz																		
TA D.B.	-25	-10	0	7	20	35	-25	-10	0	7	20	35	-25	-10	0	7	20	35
TWu	50						55						60					
Glycol	-	0	0	0	0	0	-	0	0	0	0	0	-	-	0	0	0	0
PH	-	7.57	9.48	11.57	12.52	7.84	-	7.23	9.11	11.08	12.01	7.27	-	-	8.61	10.41	11.31	6.45
pe	-	3.33	3.69	3.75	3.38	1.75	-	3.65	4.03	4.10	3.69	1.91	-	-	4.39	4.48	4.02	2.09
EER	-	2.27	2.57	3.08	3.70	4.48	-	1.98	2.26	2.70	3.26	3.80	-	-	1.96	2.32	2.81	3.08
Qu	-	1331	1665	2029	2194	1379	-	1274	1603	1947	2110	1281	-	-	1518	1834	1991	1140
AP	-	69	63	53	47	68	-	70	64	55	50	70	-	-	66	58	54	72

HMI140T - 380-415V/3N/50Hz																		
TA D.B.	-25	-10	0	7	20	35	-25	-10	0	7	20	35	-25	-10	0	7	20	35
TWu	25						35						45					
Glycol	0	0	0	0	0	0	0	0	0	0	0	0	-	0	0	0	0	0
PH	6.12	9.87	12.17	13.16	13.84	8.29	5.68	9.16	11.77	14.05	14.88	9.49	-	8.99	11.36	14.05	14.93	9.54
pe	1.69	2.43	2.75	2.64	2.35	1.23	2.35	3.03	3.34	3.22	3.04	1.59	-	3.64	4.03	4.18	3.72	1.93
EER	3.63	4.07	4.42	4.98	5.89	6.74	2.42	3.02	3.52	4.36	4.89	5.95	-	2.47	2.82	3.36	4.02	4.95
Qu	1068	1717	2114	2285	2401	1445	996	1601	2053	2447	2590	1657	-	1577	1988	2456	2608	1672
AP	72	61	50	44	40	67	73	64	52	39	34	63	-	65	54	39	33	63

HMI140T - 380-415V/3N/50Hz																		
TA D.B.	-25	-10	0	7	20	35	-25	-10	0	7	20	35	-25	-10	0	7	20	35
TWu	50						55						60					
Glycol	-	0	0	0	0	0	-	0	0	0	0	0	-	-	0	0	0	0
PH	-	8.82	11.04	13.48	14.59	9.14	-	8.42	10.61	12.91	14.00	8.47	-	-	10.03	12.13	13.18	7.52
pe	-	3.98	4.42	4.51	4.06	2.10	-	4.36	4.82	4.92	4.43	2.29	-	-	5.25	5.37	4.82	2.51
EER	-	2.21	2.50	2.99	3.59	4.35	-	1.93	2.20	2.62	3.16	3.70	-	-	1.91	2.26	2.73	3.00
Qu	-	1549	1937	2361	2553	1605	-	1483	1866	2266	2456	1491	-	-	1767	2135	2318	1327
AP	-	65	56	42	35	64	-	67	58	45	39	66	-	-	60	49	43	69

HMI160T - 380-415V/3N/50Hz																		
TA D.B.	-25	-10	0	7	20	35	-25	-10	0	7	20	35	-25	-10	0	7	20	35
TWu	25						35						45					
Glycol	0	0	0	0	0	0	0	0	0	0	0	0	-	0	0	0	0	0
PH	6.76	10.91	13.46	14.56	15.31	9.17	6.28	10.13	13.02	15.54	16.47	10.49	-	9.95	12.56	15.54	16.52	10.55
pe	1.89	2.72	3.09	2.97	2.65	1.38	2.63	3.40	3.75	3.60	3.43	1.79	-	4.08	4.53	4.70	4.18	2.16
EER	3.58	4.01	4.35	4.90	5.78	6.63	2.39	2.98	3.47	4.32	4.80	5.86	-	2.44	2.78	3.31	3.95	4.88
Qu	1180	1898	2336	2525	2654	1596	1100	1769	2269	2704	2863	1831	-	1743	2197	2714	2882	1847
AP	71	57	43	36	31	64	72	60	45	30	24	58	-	61	47	29	23	58

HMI160T - 380-415V/3N/50Hz																		
TA D.B.	-25	-10	0	7	20	35	-25	-10	0	7	20	35	-25	-10	0	7	20	35
TWu	50						55						60					
Glycol	-	0	0	0	0	0	-	0	0	0	0	0	-	-	0	0	0	0
PH	-	9.75	12.21	14.91	16.14	10.11	-	9.31	11.74	14.28	15.49	9.36	-	-	11.09	13.42	14.58	8.31
pe	-	4.46	4.95	5.06	4.57	2.35	-	4.89	5.41	5.52	4.98	2.57	-	-	5.89	6.02	5.42	2.81
EER	-	2.18	2.47	2.95	3.53	4.29	-	1.90	2.17	2.59	3.11	3.65	-	-	1.88	2.23	2.69	2.96
Qu	-	1712	2141	2610	2822	1774	-	1639	2062	2504	2715	1647	-	-	1953	2359	2561	1467
AP	-	62	49	33	25	60	-	63	52	37	29	63	-	-	55	42	35	67

Data 14511:2018

- TA D.B. Outside air temperature - dry bulb (°C)
  - TWu Water temperature - services side (°C)
  - Glycol % Minimum recommended percentage of ethylene glycol (%)
  - Ph Heating capacity (kW)
  - Pe Input power (kW)
  - Qu Water flow rate - services side (l/h)
  - HP Useful head, net of pressure drops (kPa)
- Flow rates and useful head values calculated with  $\Delta T 5^\circ C$

**NB:**  
for operating conditions other than those stated, refer to the Magellano selection program, available at [www.aermec.com](http://www.aermec.com)

## USEFUL HEAD VALUES

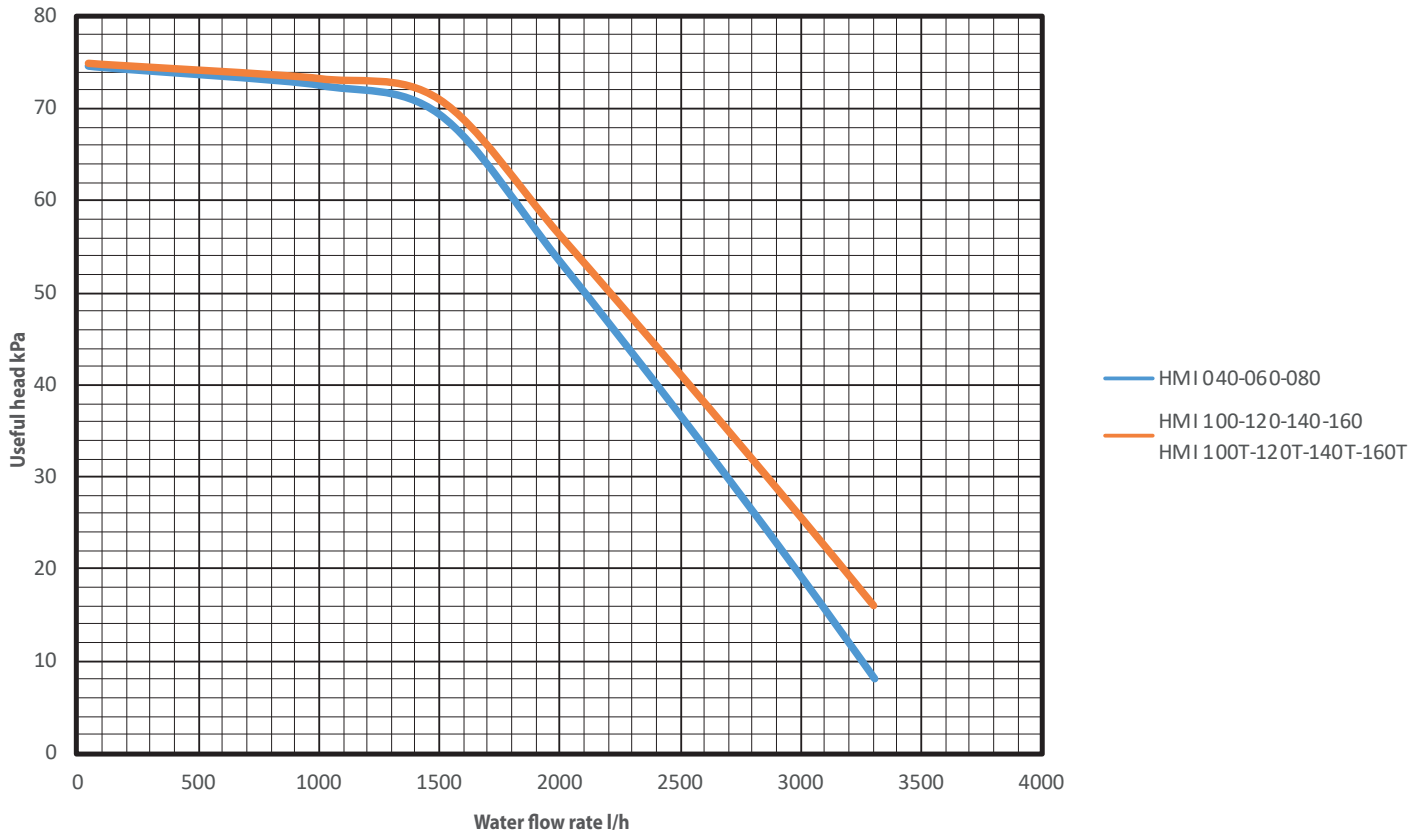

**NB:**

- the unit automatically controls the circulator via signals of the PWM type, according to the operating conditions; this means that no settings are needed at the time of installation
- the unit must be sized on the basis of the nominal design conditions and, in those conditions, must guarantee that the pressure drops (system side) are less than - or equal to - the useful head available.

# WATER VOLUME AND PRESSURE IN THE EXPANSION TANK

**THE TOTAL MINIMUM WATER VOLUME IS 20 LITRES.**

**The method used to calculate the expansion tank load pressure needed for adjustment is as follows:**

During installation, if the volume of the water system has changed, check whether the pre-load pressure of the expansion tank requires adjustment using the following formula:

$$P_g = (H/10+0.3) \text{ bar}$$

H = the difference between the unit installation position and the highest point of the hydraulic system [m].

Make sure the volume of the hydraulic system is less than the maximum volume required (as shown in the figure). If this is not the case, the expansion tank does not meet installation requirements.

**SAFETY VALVE CALIBRATED AT 2.5 bar.**

## HMI 040-060-080

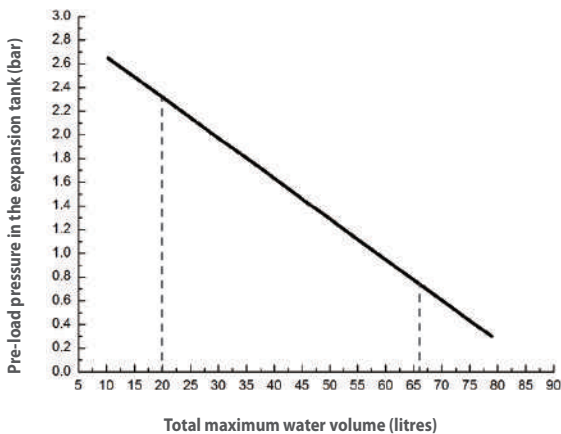

## HMI 100-120-140-160 HMI 100-120-140-160 T

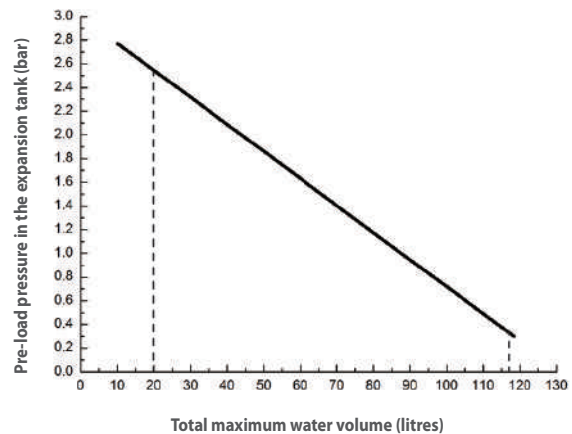

NB:  
the expansion tank contains 2 litres at a pre-load pressure of 1.5 bar.  
The total water volume of 44 litres is pre-set. If it has to be changed because of installation conditions, the pre-load pressure must be adjusted to ensure appropriate operation.  
If the unit is positioned at the highest point, no adjustment is necessary.  
The total minimum water volume is 20 litres.  
The maximum total water volume is 66 litres.  
To adjust the pre-load pressure, use nitrogen from a certified technical installation supplier.

NB:  
the expansion tank contains 3 litres at a pre-load pressure of 1.5 bar.  
The total water volume of 66 litres is pre-set. If it has to be changed because of installation conditions, the pre-load pressure must be adjusted to ensure appropriate operation.  
If the unit is positioned at the highest point, no adjustment is necessary.  
The total minimum water volume is 20 litres.  
The maximum total water volume is 118 litres.  
To adjust the pre-load pressure, use nitrogen from a certified technical installation supplier.

Difference in height of installation <sup>1</sup>	Water volume (see dwg. above)	
	<44L	>44L
H < 12m	Adjustment is not necessary	<ul style="list-style-type: none"> <li>The pre-set pressure must be adjusted using the formula provided above.</li> <li>Check that the volume of water is less than maximum. (Refer to the figure above).</li> </ul>
H ≥ 12m	<ul style="list-style-type: none"> <li>The pre-set pressure must be adjusted using the formula provided above.</li> <li>Check that the volume of water is less than maximum. (Refer to the figure above).</li> </ul>	The expansion tank is too small and it is not possible to perform the adjustment.

Difference in height of installation <sup>1</sup>	Water volume (see dwg. above)	
	<66L	>66L
H < 12m	Adjustment is not necessary	<ul style="list-style-type: none"> <li>The pre-set pressure must be adjusted using the formula provided above.</li> <li>Check that the volume of water is less than maximum. (Refer to the figure above).</li> </ul>
H ≥ 12m	<ul style="list-style-type: none"> <li>The pre-set pressure must be adjusted using the formula provided above.</li> <li>Check that the volume of water is less than maximum. (Refer to the figure above).</li> </ul>	The expansion tank is too small and it is not possible to perform the adjustment.

<sup>(1)</sup> NOTE: The difference in installation height is the difference between the unit installation position and the highest point of the hydraulic system. If the unit is positioned at the highest installation point, the difference will be assumed to be 0m.

**Example 1:**

The HMI160 unit is installed 5m below the highest point of the system, and the total volume of the hydraulic system is 60 litres.

Referring to the table, you can see it is not necessary to adjust the pressure of the expansion tank.

**SELECTING THE EXPANSION TANK**

Formula:

$$V = \frac{c \cdot e}{1 - \frac{1+p_1}{1+p_2}}$$

V = Expansion tank volume

c = Total water volume

p<sub>1</sub> = Pre-load pressure of the expansion tank [bar]

p<sub>2</sub> = Maximum pressure during system operation (i.e. safety valve intervention value) [bar].

e = Water expansion factor (the difference between the original water temperature expansion factor and the highest water temperature).

WATER EXPANSION FACTOR AT VARIOUS TEMPERATURES	
Temperature (°C)	Expansion factor (e)
0	0,00013
4	0
10	0,00027
20	0,00177
30	0,00435
40	0,00782
45	0,0099
50	0,0121
55	0,0145
60	0,0171
65	0,0198
70	0,0227
75	0,0258
80	0,029
85	0,0324
90	0,0359
95	0,0396
100	0,0434

# GLYCOL

## ETHYLENE GLYCOL

### COOLING MODE

CORRECTION FACTOR WITH ETHYLENE GLYCOL - COOLING MODE											
Freezing Point	°C	0	-3.63	-6.10	-8.93	-12.11	-15.74	-19.94	-24.79	-30.44	-37.10
Percent ethylene glycol	%	0	10	15	20	25	30	35	40	45	50
Qwc	-	1.000	1.033	1.040	1.049	1.060	1.072	1.086	1.102	1.120	1.141
Pc	-	1.000	0.990	0.985	0.980	0.975	0.970	0.965	0.960	0.955	0.950
Pa	-	1.000	0.996	0.994	0.992	0.990	0.988	0.986	0.984	0.982	0.980
Dp	-	1.000	1.109	1.157	1.209	1.268	1.336	1.414	1.505	1.609	1.728

Average water temperature = 9.5 °C

### HEATING MODE

CORRECTION FACTOR WITH ETHYLENE GLYCOL - HEATING MODE											
Freezing Point	°C	0	-3.63	-6.10	-8.93	-12.11	-15.74	-19.94	-24.79	-30.44	-37.10
Percent ethylene glycol	%	0	10	15	20	25	30	35	40	45	50
Qwh	-	1.000	1.027	1.038	1.050	1.063	1.078	1.095	1.114	1.135	1.158
Ph	-	1.000	1.000	1.000	1.000	1.000	1.000	1.000	1.000	1.000	1.000
Pa	-	1.000	1.002	1.003	1.004	1.005	1.007	1.008	1.010	1.012	1.015
Dp	-	1.000	1.087	1.128	1.175	1.227	1.286	1.353	1.428	1.514	1.610

Average water temperature = 42.5 °C

**Qwc:** Corrective factor of flow rates (middle water temperatur 9.5°C)

**Qwh:** Corrective factor of flow rates (middle water temperatur 42.5°C)

**Pc:** Corrective factor of cooling capacity

**Ph:** Corrective factor of heating capacity

**Pa:** Corrective factor of input power

**Dp:** Corrective factor of pressure drop

## PROPYLENE GLYCOL

### COOLING MODE

CORRECTION FACTOR WITH PROPYLENE GLYCOL - COOLING MODE											
Freezing Point	°C	0	-3.43	-5.30	-7.44	-9.98	-13.08	-16.86	-21.47	-27.04	-33.72
Percent PROPYLENE glycol	%	0	10	15	20	25	30	35	40	45	50
Qwc	-	1.000	1.007	1.006	1.007	1.010	1.015	1.022	1.032	1.044	1.058
Pc	-	1.000	0.985	0.978	0.970	0.963	0.955	0.947	0.939	0.932	0.924
Pa	-	1.000	0.996	0.994	0.992	0.990	0.988	0.986	0.984	0.982	0.980
Dp	-	1.000	1.082	1.102	1.143	1.201	1.271	1.351	1.435	1.520	1.602

Average water temperature = 9.5 °C

### HEATING MODE

CORRECTION FACTOR WITH PROPYLENE GLYCOL - HEATING MODE											
Freezing Point	°C	0	-3.43	-5.30	-7.44	-9.98	-13.08	-16.86	-21.47	-27.04	-33.72
Percent PROPYLENE glycol	%	0	10	15	20	25	30	35	40	45	50
Qwh	-	1.000	1.008	1.014	1.021	1.030	1.042	1.055	1.071	1.090	1.112
Ph	-	1.000	1.000	1.000	1.000	1.000	1.000	1.000	1.000	1.000	1.000
Pa	-	1.000	1.003	1.004	1.005	1.007	1.009	1.011	1.014	1.018	1.023
Dp	-	1.000	1.050	1.077	1.111	1.153	1.202	1.258	1.321	1.390	1.467

Average water temperature =42.5 °C

**Qwc:** Corrective factor of flow rates (middle water temperatur 9.5°C)

**Qwh:** Corrective factor of flow rates (middle water temperatur 42.5°C)

**Pc:** Corrective factor of cooling capacity

**Ph:** Corrective factor of heating capacity

**Pa:** Corrective factor of input power

**Dp:** Corrective factor of pressure drop



**Do not fill up the hydraulic system by glycol near the suction of the pump. High concentration of glycol could stuck the pump. Do not use the pump to mix water and glycol**

## SOUND DATA

Sound power based on measurements taken in compliance with ISO 3744:1994 in a semi-anechoic chamber.

This certification refers specifically to sound power in dB(A), so this is the only sound value which should be considered binding.

Unit	Notes	Total sound levels		Octave band (Hz)							
		Pow. dB(A)	Pres. 1m dB(A)	63	125	250	500	1000	2000	4000	8000
<b>Sound power by central band frequency [dB] (A)</b>											
<b>040</b>		64	50	45,1	46,2	54,1	59,1	59,9	53,9	49,6	44,1
<b>060</b>		64	50	45,6	46,7	54,1	59,1	59,9	53,9	49,6	44,1
<b>080</b>		65	51	44,6	47,1	53,9	56,1	61,2	59,7	52,1	44,3
<b>100</b>		69	54	48,7	57,0	60,0	64,3	63,8	59,9	51,2	53,4
<b>120</b>		69	54	48,5	56,2	58,6	63,5	65,1	59,4	52,7	53,8
<b>140</b>		70	55	51,5	55,9	60,1	65,4	65,5	59,1	53,9	55,7
<b>160</b>		72	57	54,1	57,6	61,8	66,9	68,0	61,7	55,8	56,7
<b>100T</b>		69	54	48,7	57,0	60,0	64,3	63,8	59,9	51,2	53,4
<b>120T</b>		69	54	48,5	56,2	58,6	63,5	65,1	59,4	52,7	53,8
<b>140T</b>		70	55	51,5	55,9	60,1	65,4	65,5	59,1	53,9	55,7
<b>160T</b>		72	57	54,1	57,6	61,8	66,9	68,0	61,7	55,8	56,7

### **Working conditions - heating mode**

Processed water temperature 55°C;

Outside air temperature 7°C.







SCARICA L'ULTIMA  
VERSIONE:

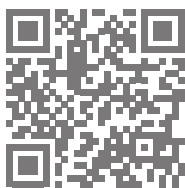

DOWNLOAD THE LATEST  
VERSION:

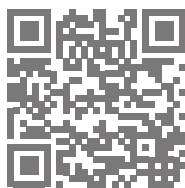

TÉLÉCHARGER LA DERNIÈRE  
VERSION:



BITTE LADEN SIE DIE LETZTE  
VERSION HERUNTER:



DESCARGUE LA ÚLTIMA  
VERSIÓN:

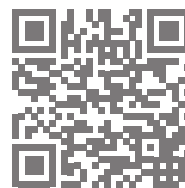

<http://www.aermec.com/qrcode.asp?q=14330>

<http://www.aermec.com/qrcode.asp?q=14331>

<http://www.aermec.com/qrcode.asp?q=14332>

<http://www.aermec.com/qrcode.asp?q=14333>

<http://www.aermec.com/qrcode.asp?q=14334>



AERMEC S.p.A.

Via Roma, 996 - 37040 Bevilacqua (VR) - Italia

Tel. +39 0442 633111 - Fax +39 0442 93577

marketing@aermec.com - www.aermec.com