

RTG 050Y-135Y

Roof-Top for high-crowding applications

Cooling capacity 48,2 ÷ 140,8 kW
Heating capacity 49,0 ÷ 139,5 kW



- For high-crowding applications
- R32 refrigerant gas
- High efficiency also at partial loads
- High power modulation capacity
- Compressors and fans with Inverter
- Upgraded thermodynamic heat recovery



DESCRIPTION

Independent Roof-top type air cooled air conditioner, for treatment, filtration and renewal of the air, based on the chosen configuration. These are outdoor units using environmentally friendly R32 gas. The RTG 050Y-135Y units are designed for highly crowded contexts such as cinemas, conference halls, restaurants and discos, as they work with 80% outside and exhaust air. The unit allow to manage for free-cooling mode and the thermodynamic recovery (MB4) and enhanced thermodynamic (MBT) of the energy contained in the exhaust air is provided, allowing for higher output and efficiency levels.

VERSIONS

H Heat pump

FEATURES

Refrigerant HFC R32

Thanks to the R32 refrigerant (A2L slightly flammable), the environmental impact of the units is significantly reduced. Combining a reduced refrigerant load with a low global warming potential (GWP), these units boast low equivalent CO₂ values.

Inverter compressor

All models use inverter-driven scroll compressors, which allow them to perfectly comply with the energy levels required by European regulations. Inverter technology enables high seasonal energy efficiencies, reduced noise level at partial loads and high environmental comfort

Inverter fans

The air treatment cross-section ventilation, which represents the highest expense in terms of machine operating costs, is entrusted to the plug fans with EC brushless motors, efficiency class IE5, which enable high performance, easy flow rate adjustment, compactness, low noise, versatility and easy maintenance. Two types of flow fans are available: the standard one and the enhanced one for a higher useful static pressure.

Axial fans

The axial fans on the source side are helical, electrically and mechanically protected by grilles, and are equipped with **brushless EC motors, efficiency class IE5**. Electronic control of summer condensation temperature and winter evaporation temperature is standard.

Air filtration

A Coarse 55% corrugated filter according to ISO 16890 (G4 according to EN 779), with synthetic fibre filter media protected by wire mesh on both sides and a galvanised sheet steel frame is included as per standard. The filters are placed on guides and are easily removable from the side. Downstream it is possible to insert an additional filtration stage with ePM1 50% efficiency according to ISO 16890 (F7 according to EN 779) or ePM1 80% efficiency according to ISO 16890 (F9 according to EN 779). As an alternative to mechanical filters, electrostatic filters can be fitted for even higher filtration efficiency and lower maintenance costs. Air quality control systems are also available (VOC and CO₂ probe).

Exchangers

The internal and external heat exchangers are made of copper pipes and aluminium louvers blocked by mechanical expansion of the pipes. They are the high efficiency type with internally striped pipe and corrugated louvers. To protect the louvers from corrosion, pre-painted aluminium louvers are available as an alternative.

Thermoregulation

Electronic controller able to manage the different functioning modes, ensuring maximum energy savings in all conditions of use by means of special software. Interfaces to connect to remote supervision and control systems available as options. The electrical panel complete with all devices is easily accessible. The free-cooling/heating and defrosting logics are particularly sophisticated. As soon as the external conditions allow it, the unit is able to automatically activate the free-cooling or free-heating mode, which cools or heats the served room, while keeping the compressors off and introducing suitably treated external air. This mode significantly reduces both energy consumption and wear of the compressors. These functions are also used when the external air energy content is not enough to cool or heat the room.

Air flow management

There are different types of supply and exhaust (if present) air flow rate control.

With constant flow rate control, air flows are kept constant at the set value regardless of the heat load and varying pressure drops of the machine/plant system.

With variable flow rate control, the air flows vary depending on the heat load between the set nominal value and the minimum value of the unit.

CONFIGURATIONS

MB4: double ventilating cross-section (flow and expulsion) for recovery air, external air and exhaust air, thermodynamic recovery.

Recovery, external and exhaust air configuration. The flow ventilating cross-section provides the flow and recovery useful static pressure. The exhaust ventilating cross-section only controls the air flow rate to be expelled, with consequent reduction of the installed ventilation power.

Thermodynamic recovery is performed by conveying expelled air on the external heat exchangers.

Possibility of performing freecooling/freeheating.

MBT: double ventilating cross-section (flow and expulsion) for recovery air, external air and exhaust air, upgraded thermodynamic recovery.

Recovery, external and exhaust air configuration. The flow ventilating cross-section provides the flow and recovery useful static pressure.

With variable flow rate, in addition to the benefits in terms of environmental comfort, there are also economic benefits as the modulation of the air flow rate leads to a considerable reduction in the electricity consumption of the unit compared to a unit operating with a fixed flow rate.

A function can also be enabled that in Economy mode, when the temperature set-point is reached, allows ventilation to be switched off, with considerable economic advantages.

The exhaust ventilating cross-section only controls the air flow rate to be expelled, with consequent reduction of the installed ventilation power.

Possibility of performing freecooling/freeheating.

The MBT configuration allows for the upgraded thermodynamic recovery on the exhaust flow and transfer it to the cooling circuit, increasing the treatment coil performance without increasing the input power of the compressors.

The coil, perfectly hit by the air flow, recovers the energy still present in the exhaust flow and transfer it to the cooling circuit, increasing the treatment coil performance without increasing the input power of the compressors.

In summer functioning, the coil makes it possible to increase the liquid sub-cooling, while in winter functioning, the coil takes on part of the evaporation by operating the cooling circuit at more advantageous temperatures.

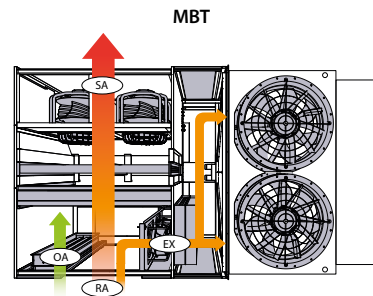
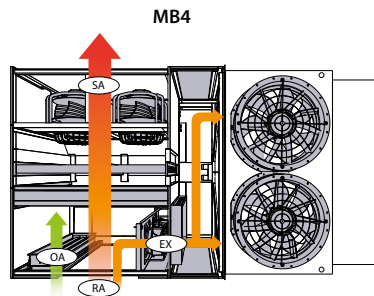

SA: Flow air
RA: Return air
OA: External air
EX: Air expelled

ACCESSORIES

Refer to the selection software for compatibility of accessories.

MB4: Double fan section - Recirculation Renewal + Exhaust - Thermodynamic recovery

MBT: Double fan section - Recirculation + Renewal + Exhaust - Enhanced thermodynamic recovery

MO: Horizontal air flow

MI: Lower air flow

MS: Upper air flow

RO: Horizontal air recovery

RI4: Lower air recovery for MB4/MBT configuration

RS4: Upper air recovery for MB4/MBT configuration

VSTD: Fans with standard static pressure

VPWR: Fans with increased static pressure

IAL: Internal coil with aluminium louvers

IPV: Internal coil with pre-painted aluminium louvers

EAL: External coil with aluminium louvers

EPV: External coil with pre-painted aluminium louvers

IALT: MBT internal coil with aluminium louvers

IPVT: MBT internal coil with pre-painted aluminium louvers

EALT: MBT external coil with aluminium louvers

EPVT: MBT external coil with pre-painted aluminium louvers

FCT: Thermal free-cooling

FCH: Enthalpy free-cooling

CMAN: Manual external damper control

SCM: Modulating external damper servocontrol

SCM-F: MBF modulating damper servocontrols

PCOST: Constant air flow rate

PVAR: Variable air flow rate

DML: Demand limit

PFS: Filter fouling control differential pressure switch

DEU: Summer dehumidification

DEUP: Summer dehumidification with post-heating

CUR: Provision for humidification control (digital contact and analogue output)

BPGC: Hot gas after-heating coil with aluminium louvers

BPGCPV: Hot gas after-heating coil with pre-painted aluminium louvers

BW2: Heating/Integration water coil with aluminium louvers

BW2PV: Heating/Integration water coil with pre-painted aluminium louvers

BW3: Water coil for recovery from refrigerated display cabinets with aluminium louvers

BW3PV: Water coil for recovery from refrigerated display cabinets with pre-painted aluminium louvers

V2V: Modulating 2-way valve + connecting pipes

V3V: Modulating 3-way valve + connecting pipes

BE: 2-stage electric heating coil (3 steps)

F7: F7 filters (ISO 16890 ePM1 55%)

F9: F9 filters (ISO 16890 ePM1 80%)

FE1: Electrostatic filters for MB1/MB2 configuration

FE4: Electrostatic filters for MB4/MBT/MBF configuration

SCO2: CO2 duct probe

SVOC: VOC duct probe

SCO2+SVOC: CO2 + VOC duct probe

ASCO2: Room CO2 probe

ASVOC: Room VOC probe

ASCO2+SAVOC: Room CO2 + VOC probe

STR: Recovery temperature probe
STA: Room temperature probe
STR+SUR: Recovery temperature and humidity probe
STA+SUA: Room temperature and humidity probe
PRT1: Remote panel up to 50m
PRT2: Remote panel up to 200m
AVG: Anti-vibration supports

MIP: Modbus TCP/IP communication protocol (standard)
MRTU: Modbus RTU communication module
BIP: Bacnet IP communication module
BMSTP: Bacnet MS/TP communication module
KON: KONNEX communication module
CAP: Hoods function
CFF: Fire/smoke contact

PERFORMANCE SPECIFICATIONS

■ *Unit input power: at nominal air flow rate, nominal high static pressure and standard fans*

MB4

Size		050	090	135
Configuration: MB4				
Cooling performances				
Cooling capacity	kW	48,20	82,90	130,00
Sensible cooling capacity	kW	33,80	59,30	86,90
Compressors absorbed power	kW	10,50	19,90	36,90
EER compressors		4,60	4,16	3,52
Unit input power	kW	13,8	26,3	45,7
Heating performances				
Heating capacity	kW	49,00	84,90	129,20
Compressors absorbed power	kW	9,00	17,10	27,50
Compressor COP		5,45	4,96	4,69
Unit input power	kW	11,1	21,3	35,3

Cooling performances: Ambient air 27°C d.b./19°C w.b.; External air 35°C/24°C w.b.; Functioning with 80% of external and expelled air. (MB4, MBT)

Heating performances: Ambient air 20°C d.b./15°C w.b.; External air 7°C/6°C w.b.; Functioning with 80% of external and expelled air. (MB4, MBT)

MBT

Size		050	090	135
Configuration: MBT				
Cooling performances				
Cooling capacity	kW	52,50	91,30	140,80
Sensible cooling capacity	kW	37,10	65,90	94,80
Compressors absorbed power	kW	10,50	20,10	37,00
EER compressors		5,01	4,55	3,80
Unit input power	kW	13,9	27,0	47,2
Heating performances				
Heating capacity	kW	52,70	91,60	139,50
Compressors absorbed power	kW	9,10	16,20	28,40
Compressor COP		5,82	5,66	4,91
Unit input power	kW	11,3	21,2	38,1

Cooling performances: Ambient air 27°C d.b./19°C w.b.; External air 35°C/24°C w.b.; Functioning with 80% of external and expelled air. (MB4, MBT)

Heating performances: Ambient air 20°C d.b./15°C w.b.; External air 7°C/6°C w.b.; Functioning with 80% of external and expelled air. (MB4, MBT)

ENERGY INDEX

Size		050	090	135
Energy index				
SEER	W/W	6,10	6,32	6,44
η_{sc}	%	241,20	249,90	254,60
SCOP	W/W	4,41	3,93	3,93
η_{sh}	%	173,30	154,20	154,10

■ *In MB1 configuration according to EN 14825:2022*

GENERAL TECHNICAL DATA

Size		050	090	135
Power supply				
Power supply		400V 3~ 50Hz	400V 3~ 50Hz	400V 3~ 50Hz
Compressor				
Type	type	Scroll	Scroll	Scroll
Number	no.	2	2	2
Circuits	no.	2	2	2
Refrigerant	type	R32	R32	R32
Compressor regulation	Type	Inverter	Inverter	Inverter
Sound data				
Sound power level	dB(A)	84,0	86,0	90,0

- Sound power in MB4 configuration at nominal operating conditions calculated on the basis of measurements in accordance with UNI EN ISO 9614-1/2

FANS

External fans

Size		050	090	135
Configuration: MB4, MBT				
External fans				
Type	type		Axials EC	
Number	no.	2	2	2

Internal flow fans

Size		050	090	135
Configuration: MB4, MBT				
Delivery				
Type	type		Plug fan EC	
Number	no.	1	1	2
Nominal air flow rate	m ³ /h	6000	11000	16500
Minimum air flow rate	m ³ /h	3800	7000	13000
Maximum air flow rate	m ³ /h	7500	13500	20500
Nominal high static pressure (EN14511)	Pa	150	200	250

Expulsion fan

Size		050	090	135
Configuration: MB4, MBT				
Exhaust				
Type	type		Plug fan EC	
Number	no.	1	2	3
Nominal useful head	Pa	75	100	125

DIMENSIONS

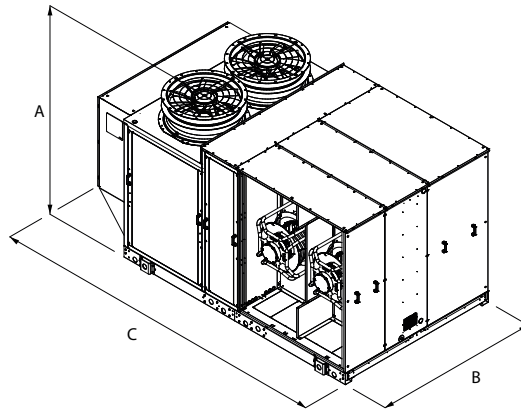

Size		050	090	135
Dimensions and weights				
A	mm	1570	1900	2165
B	mm	2200	2200	2200
C	mm	3305	3905	3905
Empty weight	kg	1263	1560	1718

■ Empty weight: in MB4 configuration without accessories

Aermec reserves the right to make any modifications deemed necessary. All data is subject to change without notice. Aermec does not assume responsibility or liability for errors or omissions.

Aermec S.p.A.
Via Roma, 996 - 37040 Bevilacqua (VR) - Italia
Tel. 0442633111 - Telefax 044293577
www.aermec.com