

VED 430-741

Fan coil unit for ducted installations



- Horizontal and vertical installation
- Ventilation group to 5 speed
- Large range of available static pressure
- Inspectable ventilation group



DESCRIPTION

Ducted fan coil, for heating, cooling and dehumidifying. Designed to maintain the set temperature over time, ensuring very low sound levels. Can be installed in any 2/4 pipe system and operates with any heat generator even at low temperatures. Thanks to the availability of various options, with standard or increased coil, for horizontal or vertical installation, it is easy to choose the optimal solution for any need.

FEATURES

Case

Unit for internal installation. Internally insulated structure with class 1 fire resistance and IP20 protection.

Ventilation group

Centrifugal fans in anti-static plastic material with aerofoil profile designed to achieve high airflows and pressures whilst at the same time producing low noise. Their characteristics permit energy savings compared to conventional fans. They are statically and dynamically balanced and directly coupled to the motor shaft. The electric motor is single-phase multi-speed (3 selectable), mounted on anti-vibration supports and with a permanently inserted capacitor. Fan housing in plastic material removable for easy and effective cleaning.

Heat exchanger coil

With copper pipes and aluminium louvers, the main heat exchanger has female gas water connections on the left side and the manifolds have air vents. The coil is not suitable for use in corrosive atmosphere or in environments where aluminium may be subject to corrosion.

The hydraulic connections can be inverted during installation.

Air filter

Air filter Class G3, for easy removal and cleaning.

Controls and Accessoires

There is a wide selection of controls and a huge choice of accessories, to meet every system requirement. The unit is supplied with the delivery connection supplied.

ACCESSORIES



Control panels

AER503IR: Flush-mounting thermostat with backlit display, capacitive keypad and infrared receiver, for controlling both brushless fan coils and those with an asynchronous motor. In 2-pipe systems, the thermostat can control standard fan coils or those equipped with an electric heater, with air purifying devices (Cold Plasma and germicidal lamp), with radiant plate or with FCZ-D twin delivery (Dualjet). In addition, it can control systems with radiant panels or mixed (fan coil and radiant floor) systems. Being equipped with an infrared receiver, it can, in turn, be controlled by the VMF-IR remote control.

PRO503: Wall box for AER503IR and VMF-E4 thermostats.

SA5: air probe kit (L = 15 m) with probe-locking cable grommet.

SIT3: Thermostat Interface Card allowing the creation of a network of fan coils (max. 10) commanded by a central control panel (selector or thermostat). Commands the 3 fan speeds and must be installed on each fan coil within the network; receives the commands from the selector or the SIT5 card. In case you decide to install Aermec thermostats and current absorbed by the unit exceeds 0.7 A, you're obliged to include SIT3 accessory.

SIT5: Thermostat Interface Card allowing the creation of a network of fan coils (max. 10) commanded by a central control panel. Commands the 3 fan

speeds and up to 2 valves (four pipe systems); sends the thermostat's commands to the fan coil network.

SW3: Water probe (L = 2.5 m) for controlling the minimum and maximum and to allow automatic seasonal switching for electronic thermostats fitted with water side changeover.

SW5: water probe kit (L = 15m) with probe-holder connection point, fixing clip and probe-holder from heat exchanger.

TX: Wall-mounting thermostat for controlling either brushless fan coils or those with asynchronous motors for 2/4 pipe. In 2-pipe systems, the thermostat can control standard fan coils or those equipped with an electric heater, with air purifying devices, radiant plate or FCZ-D twin delivery (Dualjet).

WMT10: Electronic thermostat, white, with thermostated or continuous ventilation.

WMT16: Electronic thermostat with thermostated ventilation.

WMT16CV: Electronic thermostat with continuous ventilation.

AerSuite

The AerSuite application is used to remotely control the DI24 user interface, with VMF-E19/VMF-E19I thermostats, using Smart Devices with iOS and Android operating systems.

This is an application for Smartphones and Tablets with which the user can access and control the system operation remotely.

For more information about the use of the application and the available functions, refer to the respective documentation on the website.



VMF system

DI24: Flush-mounted interface (503 box) with 2.4" touch screen display to be combined with VMF-E19, VMF-E19I accessories. It allows you to regulate and monitor the temperature inside rooms precisely and on time; in addition to accessing and interacting with your system's operating information, parameters and alarms, it allows you to set time slots. Thanks to its Wi-Fi connection, DI24 in combination with the AerSuite APP (available for Android and iOS) can also be remotely controlled. All programming and most functions are done in a simple and intuitive way using the APP. To allow for customization of the interface so that it seamlessly integrates with the style of any home, DI24 is compatible with switch plates from major brands available on the market. For more information, please refer to our documentation. However, a switch plate with its graphite gray support, DI24CP, is also available as a separate accessory in our catalog.

VMF-E19: Thermostat to be secured to the side of the fan coil, fitted as standard with an air probe and a water probe.

VMF-E3: Wall mounted user interface, to be combined with accessories VMF-E19, VMF-E19I, with grids GLF_N/M and GLL_N, can be controlled with VMF-IR control.

VMF-E4DX: Wall-mounted user interface. Grey front panel PANTONE 425C (METAL).

VMF-E4X: Wall-mounted user interface. Light grey front panel PANTONE COOL GRAY 1C.

VMF-IO: Manage the unit exclusively from a centralized VMF control panel without area control panel.

VMF-IR: User interface compatible with the AER503IR, VMF-E3 thermostat and with all the grids of cassettes equipped with the infrared receiver compatible with the VMF system.

VMF-MOD: Expansion board for the management of modulating valves.

VMF-SIT3V: Relay interface board. Mandatory accessory on units where motor absorption exceeds 0.7 A. The relay interface board is supplied with a 2A fuse to protect the fan coil. If the fan coil absorbs more than 2A and up to 4A, the fuse inside must be replaced with a 4A fuse supplied.

VMF-SW: Water probe (L = 2.5m) used if required in place of the standard unit supplied with the VMF-E19 and VMF-E19I thermostats for mounting it upstream of the valve.

VMF-SW1: Additional water probe (L = 2.5m) to be used if required for 4-pipe systems with the VMF-E19 and VMF-E19I thermostats for maximum control in the cold range

VMHI: The VMHI panel can be used as a user interface for VMF-E19/E19I thermostats, GLFxN/M or GLLxN grids, or as an interface for the MZC system. What determines the function to be performed by the user interface is determined by its correct parametrisation and by following the electrical connections between interface and thermostat or interface and plenum.

Water valves

VJP: Control and balancing combination valve for 2 and 4 pipe systems to install outside the unit, supplied without fittings and hydraulic components. The valve, which can guarantee a constant water flow rate in the terminal, within its operating range.

VCT: These are 3-way ball valves made of bronze, with female/female connections Ø 1/2". That can be servo-activated via servo commands. The valves do not have fittings and pipes for water connections, which are the installer's responsibility.

VCT: These are 3-way ball valves made of bronze, with female/female connections Ø 1/2". That can be servo-activated via servo commands. The valves do not have fittings and pipes for water connections, which are the installer's responsibility.

VCTK: The VCT series valves can be combined with the actuators On-Off 230V. The actuator must be selected according to the type of system/adjustment provided.

VCTKM: The VCT series valves can be combined with the actuators 24V modulating. The actuator must be selected according to the type of system/adjustment provided.

VCF45C - 47C - 47CS - for main heat exchanger: 3-way motorised valve kit for the main heat exchanger. The kit is made up of a valve with its insulating shell, actuator and relative hydraulic fittings. It can be installed on fan coils with both right and left connections. If the valve is combined with the BCZ5 or BCZ6 condensate drain pan, to ensure a better housing it is possible to remove the insulating shell.

VCF45H - 47H - for heating only heat exchanger: Motorized 3-way valve kit for hot only coil. The kit consists of a 3-way 4-way valve, the actuator and its hydraulic fittings, it is suitable for installation on both fan coil units with hydraulic connections on the right and left.

VCF25C - 25CS - for main coil: 2-way motorized valve kit for main coil. The kit consists of a valve with its insulating shell, the actuator and the relative hydraulic fittings, it is suitable for installation on both fan coil units with hydraulic connections on the right and left.

VCF25H - for heating only coil: 2-way motorized valve kit for hot only coil. The kit consists of a valve, actuator and relative hydraulic fittings, it is suitable for installation on both fan coils with hydraulic connections on the right and left.

BCV: Condensate drip.

Installation accessories

MZC: Plenum with motorised dampers.

RDA_V: Straight intake connection with rectangular flange.

RPA_V: Suction plenum with rectangular flange; both sides have a circular push-out Ø 150mm that can be removed.

PA_V: Suction plenum with circular plastic flanges; both sides have a circular push-out Ø 150mm that can be removed.

PM_V: Internally insulated delivery plenum with circular flanges; both sides have a circular push-out Ø 150mm that can be removed.

RPM_V: Internally insulated delivery plenum with rectangular flange; both sides have a circular push-out Ø 150mm that can be removed.

KFV: Circular flanges kit for plenum.

MZCACV: Electrical system with relay interface board. Mandatory accessory on units where motor absorption exceeds 0.7 A. The relay interface board is supplied with a 2A fuse to protect the fan coil. If the fan coil absorbs more than 2A and up to 4A, the fuse inside must be replaced with a 4A fuse supplied.

MZCAC: Mandatory electrical system for connecting the MZC plenum with a fan coil fitted with an asynchronous motor.

Configurator

Field	Description
1,2,3,4	VED4
5	Size 4,5,6,7
6	main heat exchanger
3	3-row coil
4	4-row coil
7	Secondary heat exchanger
0	Without coil
1	1-row coil for heating only
2	2-row coil for heating only

ACCESSORIES COMPATIBILITY

Control panels and dedicated accessories

Model	Ver	430	432	440	441	530	532	540	541	630	632	640	641	730	732	740	741
AER503IR (1)	.	*	*	*	*	*	*	*	*	*	*	*	*	*	*	*	*
PRO503	.	*	*	*	*	*	*	*	*	*	*	*	*	*	*	*	*
SA5 (2)	.	*	*	*	*	*	*	*	*	*	*	*	*	*	*	*	*
SIT3 (3)	.	*	*	*	*	*	*	*	*	*	*	*	*	*	*	*	*
SIT5 (4)	.	*	*	*	*	*	*	*	*	*	*	*	*	*	*	*	*
SW3 (2)	.	*	*	*	*	*	*	*	*	*	*	*	*	*	*	*	*
SW5 (2)	.	*	*	*	*	*	*	*	*	*	*	*	*	*	*	*	*
TX (5)	.	*	*	*	*	*	*	*	*	*	*	*	*	*	*	*	*
WMT10 (5)	.	*	*	*	*	*	*	*	*	*	*	*	*	*	*	*	*
WMT16 (5)	.	*	*	*	*	*	*	*	*	*	*	*	*	*	*	*	*
WMT16CV (5)	.	*	*	*	*	*	*	*	*	*	*	*	*	*	*	*	*

- (1) Wall-mount installation.
- (2) Probe for AER503IR-TX thermostats, if fitted.
- (3) Cards for AER503IR-TX thermostats, if present, to be installed if the unit absorption exceeds 0,7 Ampere.
- (4) Probe for AER503IR-TX thermostats, if fitted.
- (5) Wall-mounting. If the unit intake exceeds 0.7A, or several units need to be managed with a single thermostat, board SIT3 and/or SIT5 is required.

VMF system

Model	Ver	430	432	440	441	530	532	540	541	630	632	640	641	730	732	740	741
DI24	.	*	*	*	*	*	*	*	*	*	*	*	*	*	*	*	*
VMF-E19 (1)	.	*	*	*	*	*	*	*	*	*	*	*	*	*	*	*	*
VMF-E3	.	*	*	*	*	*	*	*	*	*	*	*	*	*	*	*	*
VMF-E4DX	.	*	*	*	*	*	*	*	*	*	*	*	*	*	*	*	*
VMF-E4X	.	*	*	*	*	*	*	*	*	*	*	*	*	*	*	*	*
VMF-I0	.	*	*	*	*	*	*	*	*	*	*	*	*	*	*	*	*
VMF-IR	.	*	*	*	*	*	*	*	*	*	*	*	*	*	*	*	*
VMF-MOD	.	*	*	*	*	*	*	*	*	*	*	*	*	*	*	*	*
VMF-SIT3V (2)	.	*	*	*	*	*	*	*	*	*	*	*	*	*	*	*	*
VMF-SW	.	*	*	*	*	*	*	*	*	*	*	*	*	*	*	*	*
VMF-SW1	.	*	*	*	*	*	*	*	*	*	*	*	*	*	*	*	*
VMHI	.	*	*	*	*	*	*	*	*	*	*	*	*	*	*	*	*

- (1) Also the accessory VMF-SIT3V is mandatory if the unit exceeds 0.7 Amperes.
- (2) For the selection, consult the documentation for the thermostat and the fan coil.

Water valves

3 way valve kit

	VED430	VED440	VED530	VED540	VED630	VED640	VED730	VED740
3 way valve kit								
Main heat exchanger	VCF45C	VCF45C	VCF45C	VCF45C	VCF47C	VCF47CS	VCF47C	VCF47CS
	VED432	VED441	VED532	VED541	VED632	VED641	VED732	VED741
Main heat exchanger	VCF45C	VCF45C	VCF45C	VCF45C	VCF47C	VCF47CS	VCF47C	VCF47CS
Secondary heat exchanger for four pipes	VCF45H	VCF45H	VCF45H	VCF45H	VCF47H	VCF47H	VCF47H	VCF47H

230V power supply - Hydraulic connection Ø 3/4"

2 way valve kit

	VED430	VED440	VED530	VED540	VED630	VED640	VED730	VED740
2 way valve kit								
Main heat exchanger	VCF25C	VCF25C	VCF25C	VCF25C	VCF25C	VCF25CS	VCF25C	VCF25CS
	VED432	VED441	VED532	VED541	VED632	VED641	VED732	VED741
Main heat exchanger	VCF25C	VCF25C	VCF25C	VCF25C	VCF25C	VCF25CS	VCF25C	VCF25CS
Secondary heat exchanger for four pipes	VCF25H	VCF25H	VCF25H	VCF25H	VCF25H	VCF25H	VCF25H	VCF25H

230V power supply - Hydraulic connection Ø 3/4"

2-way globe valves actuator excluded

Ver	430	432	440	441	530	532	540	541	630	632	640	641	730	732	740	741
.	VCT102	VCT102	VCT102	VCT102	VCT102	VCT102	VCT102	VCT102	VCT202	VCT202	VCT202	VCT202	VCT202	VCT202	VCT202	VCT202

3-way globe valves actuator excluded

Ver	430	432	440	441	530	532	540	541	630	632	640	641	730	732	740	741
.	VCT103	VCT103	VCT103	VCT103	VCT103	VCT103	VCT103	VCT103	VCT203	VCT203	VCT203	VCT203	VCT203	VCT203	VCT403	VCT403

Actuator 230V

Ver	430	432	440	441	530	532	540	541	630	632	640	641	730	732	740	741
.	VCTK	VCTK	VCTK	VCTK	VCTK	VCTK	VCTK	VCTK	VCTK	VCTK	VCTK	VCTK	VCTK	VCTK	VCTK	VCTK

Actuator 24V

Ver	430	432	440	441	530	532	540	541	630	632	640	641	730	732	740	741
.	VCTKM	VCTKM	VCTKM	VCTKM	VCTKM	VCTKM	VCTKM	VCTKM	VCTKM	VCTKM	VCTKM	VCTKM	VCTKM	VCTKM	VCTKM	VCTKM

Combined adjustment and balancing valve cold side

Model	Ver	430	432	440	441	530	532	540	541	630	632	640	641	730	732	740	741
VJP150 (1)
VJP150M (2)
VJP270M (2)

(1) 230V~50Hz

(2) 24V

VJP/VJP_M the compatibility of the hot water valves with the designed air flow in a four-pipe installation is to be verified.

Accessories for intake

Intake straight with rectangular flanges

Ver	430	432	440	441	530	532	540	541	630	632	640	641	730	732	740	741
.	RDA450V	RDA450V	RDA450V	RDA450V	RDA450V	RDA450V	RDA450V	RDA450V	RDA670V	RDA670V	RDA670V	RDA670V	RDA670V	RDA670V	RDA670V	RDA670V

Intake plenum with rectangular flanges

Ver	430	432	440	441	530	532	540	541	630	632	640	641	730	732	740	741
.	RPA450V	RPA450V	RPA450V	RPA450V	RPA450V	RPA450V	RPA450V	RPA450V	RPA670V	RPA670V	RPA670V	RPA670V	RPA670V	RPA670V	RPA670V	RPA670V

Intake plenum with circular flanges

Ver	430	432	440	441	530	532	540	541	630	632	640	641	730	732	740	741
.	PA450V	PA450V	PA450V	PA450V	PA450V	PA450V	PA450V	PA450V	PA670V	PA670V	PA670V	PA670V	PA670V	PA670V	PA670V	PA670V

Delivery accessories

Delivery plenum internally insulated, with rectangular flanges

Ver	430	432	440	441	530	532	540	541	630	632	640	641	730	732	740	741
.	RPM450V	RPM450V	RPM450V	RPM450V	RPM450V	RPM450V	RPM450V	RPM450V	RPM670V	RPM670V	RPM670V	RPM670V	RPM670V	RPM670V	RPM670V	RPM670V

Delivery plenum internally insulated, with circular flanges

Ver	430	432	440	441	530	532	540	541	630	632	640	641	730	732	740	741
.	PM450V	PM450V	PM450V	PM450V	PM450V	PM450V	PM450V	PM450V	PM670V	PM670V	PM670V	PM670V	PM670V	PM670V	PM670V	PM670V

Circular flanges kit for plenum

Ver	430	432	440	441	530	532	540	541	630	632	640	641	730	732	740	741
.	KFV	KFV	KFV	KFV	KFV	KFV	KFV	KFV	KFV	KFV	KFV	KFV	KFV	KFV	KFV	KFV

Condensate drip

Ver	430	432	440	441	530	532	540	541	630	632	640	641	730	732	740	741
.	BCV45	BCV45	BCV45	BCV45	BCV45	BCV45	BCV45	BCV45	BCV67	BCV67	BCV67	BCV67	BCV67	BCV67	BCV67	BCV67

MZC

Plenum with motor-driven dampers

Ver	430	432	440	441	530	532	540	541	630	632	640	641	730	732	740	741
.	MZC5040	MZC5040	MZC5040	MZC5040	MZC5040	MZC5040	MZC5040	MZC5040	MZC7050	MZC7050	MZC7050	MZC7050	MZC7050	MZC7050	MZC7050	MZC7050

Electric plant

Ver	430	432	440	441	530	532	540	541	630	632	640	641	730	732	740	741
.	MZCAC	MZCAC	MZCAC	MZCAC	MZCAC	MZCAC	MZCAC	MZCAC	MZCAC	MZCAC	-	-	-	-	-	-

The accessory cannot be fitted on the configurations indicated with -

Electrical system with relays

Ver	430	432	440	441	530	532	540	541	630	632	640	641	730	732	740	741
.	-	-	-	-	-	-	-	-	-	-	MZCACV (1)	MZCACV (1)	MZCACV (1)	MZCACV (1)	MZCACV (1)	MZCACV (1)

(1) It is mandatory to use MZCACV if the intake of the unit combined with the MZC accessory exceeds 0.7 Ampere.

The accessory cannot be fitted on the configurations indicated with -

For more information, please refer to the MZC plenum sheet.

PERFORMANCE SPECIFICATIONS

2-pipe

	VED430			VED440			VED530			VED540			VED630			VED640			VED730			VED740					
	1	3	5	1	3	5	2	4	5	2	4	5	1	3	5	1	3	5	1	3	5	1	3	5			
	L	M	H	L	M	H	L	M	H	L	M	H	L	M	H	L	M	H	L	M	H	L	M	H			
Heating performance 70 °C / 60 °C (1)																											
Heating capacity	kW			10,47	13,85	15,97	11,45	15,36	18,11	13,80	16,47	17,57	15,38	18,59	19,91	18,63	22,67	27,02	22,45	27,74	32,69	21,18	25,36	29,00	22,88	27,65	31,71
Water flow rate system side	l/h			918	1214	1401	1004	1347	1588	1210	1444	1541	1349	1630	1746	1634	1988	2369	1969	2433	2867	1857	2224	2543	2007	2425	2781
Pressure drop system side	kPa			9	14	19	11	18	24	13	15	21	18	25	29	30	43	58	19	29	38	38	55	67	26	36	46
Heating performance 45 °C / 40 °C (2)																											
Heating capacity	kW			5,20	5,88	7,94	5,69	7,64	9,01	6,86	8,19	8,74	7,45	9,24	9,90	9,26	11,20	13,40	9,88	12,40	14,80	10,50	12,60	14,20	11,30	13,70	15,70
Water flow rate system side	l/h			894	1183	1366	979	1314	1550	1180	1409	1503	1281	1589	1703	1593	1926	2305	1699	2133	2546	1806	2167	2442	1944	2356	2700
Pressure drop system side	kPa			9	14	19	11	18	24	14	19	21	21	25	30	30	42	58	16	24	32	38	52	66	26	36	35
Cooling performance 7 °C / 12 °C																											
Cooling capacity	kW			4,54	5,98	6,72	5,21	6,88	7,79	5,99	7,16	7,49	7,26	8,31	8,70	8,67	10,43	12,19	10,20	12,50	14,80	10,17	11,92	13,48	11,73	13,95	15,71
Sensible cooling capacity	kW			3,40	4,54	5,13	3,65	4,86	5,51	4,55	5,48	5,75	4,87	5,90	6,18	7,00	8,48	9,96	7,02	8,62	10,30	8,25	9,71	11,07	8,11	9,69	10,95
Water flow rate system side	l/h			781	1029	1156	896	1183	1340	1030	1232	1288	1249	1429	1496	1491	1794	2097	1754	2150	2546	1749	2050	2319	2018	2399	2702
Pressure drop system side	kPa			8	13	17	10	17	22	12	19	21	19	25	28	26	36	48	24	34	47	35	46	58	27	37	45
Fan																											
Type	type			Centrifugal																							
Fan motor	type			Asynchronous																							
Number	no.			2			2			2			2			3			3			3			3		
Air flow rate	m ³ /h			790	1130	1350	780	1100	1340	1120	1400	1520	1100	1380	1500	1380	1800	2210	1567	2004	2440	1640	2040	2410	1600	2000	2350
High static pressure	Pa			24	50	72	-	50	63	32	50	70	32	50	56	30	50	75	30	50	75	32	50	69	32	50	64
Input power	W			137	175	228	135	178	222	175	232	270	172	230	267	220	271	340	220	293	340	234	285	371	234	285	371
Electrical wiring				V1	V3	V5	V1	V3	V5	V2	V4	V5	V2	V4	V5	V1	V3	V5	V1	V3	V5	V1	V3	V5	V1	V3	V5
Duct type fan coil sound data (3)																											
Sound power level (inlet + radiated)	dB(A)			51,0	57,0	61,0	51,0	57,0	61,0	53,0	59,0	62,0	53,0	59,0	62,0	61,0	64,0	68,0	61,0	64,0	68,0	62,0	66,0	68,0	62,0	66,0	68,0
Sound power level (outlet)	dB(A)			47,0	53,0	57,0	47,0	53,0	57,0	49,0	55,0	58,0	49,0	55,0	58,0	57,0	60,0	64,0	57,0	60,0	64,0	58,0	62,0	64,0	58,0	62,0	64,0
Diameter hydraulic fittings																											
Type	type			-																							
Main heat exchanger	Ø			3/4"																							
Finned pack heat exchanger																											
Water content main heat exchanger	l			2,9			3,9			2,9			3,9			4,7			6,3			4,7			6,3		
Power supply																											
Power supply				230V~50Hz																							

(1) Room air temperature 20 °C d.b.; Water (in/out) 70 °C/60 °C

(2) Room air temperature 20 °C d.b.; Water (in/out) 45 °C/40 °C; EUROVENT

(3) Aermec determines the sound power value on the basis of measurements taken in accordance with standard UNI EN 16583:15, respecting the Eurovent certification.

4-pipe

	VED441			VED541			VED641			VED741					
	1	3	5	2	4	5	1	3	5	1	3	5			
	L	M	H	L	M	H	L	M	H	L	M	H			
Heating performance 65 °C / 55 °C (1)															
Heating capacity	kW			5,53	6,68	7,30	6,70	7,62	7,89	9,65	11,00	12,30	10,50	11,80	12,90
Water flow rate system side	l/h			475	574	627	576	655	678	829	946	1057	903	1014	1109
Pressure drop system side	kPa			14	20	23	20	25	26	15	19	24	18	22	25
Cooling performance 7 °C / 12 °C															
Cooling capacity	kW			5,35	7,05	8,00	7,46	8,56	8,94	10,40	12,70	15,20	11,90	14,20	16,10
Sensible cooling capacity	kW			3,79	5,03	5,74	5,07	6,14	6,42	7,26	8,92	10,70	8,37	9,96	11,30
Water flow rate system side	l/h			920	1212	1376	1283	1472	1537	1788	2184	2614	2046	2442	2769
Pressure drop system side	kPa			12	19	24	21	27	29	24	35	48	27	37	46
Fan															
Type	type			Centrifugal											
Fan motor	type			Asynchronous											
Number	no.			2			2			3			3		
Air flow rate	m ³ /h			750	1060	1253	1060	1360	1453	1340	1730	2120	1600	2000	2358
High static pressure	Pa			25	50	70	32	50	57	30	50	75	32	50	69
Input power	W			121	175	215	170	229	265	224	264	341	224	288	373
Electrical wiring				V1	V3	V5	V2	V4	V5	V1	V3	V5	V1	V3	V5
Duct type fan coil sound data (2)															
Sound power level (inlet + radiated)	dB(A)			51,0	57,0	61,0	53,0	59,0	62,0	61,0	64,0	68,0	62,0	66,0	68,0
Sound power level (outlet)	dB(A)			47,0	53,0	57,0	49,0	55,0	58,0	57,0	60,0	64,0	58,0	62,0	64,0
Diameter hydraulic fittings															
Type	type			-											
Main heat exchanger	Ø			3/4"											
Secondary heat exchanger	Ø			1/2"											
Finned pack heat exchanger															
Water content main heat exchanger	l			3,9			3,9			6,3			6,3		
Water content secondary heat exchanger	l			1,0			1,0			1,6			1,6		
Power supply															

	VED441	VED541	VED641	VED741
Power supply	230V~50Hz			

(1) Room air temperature 20°C d.b.; Water (in/out) 65 °C/55 °C; EUROVENT

(2) Aermec determines the sound power value on the basis of measurements taken in accordance with standard UNI EN 16583:15, respecting the Eurovent certification.

VED	From VED 430 to 741				
Fan speed	V1	V2	V3	V4	V5
Motor connection	L5	L4	L3	L2	L1

The speed of associates may differ from the standard factory configuration.

For more information refer to the selection program and to the dedicated documentation.

DIMENSIONS

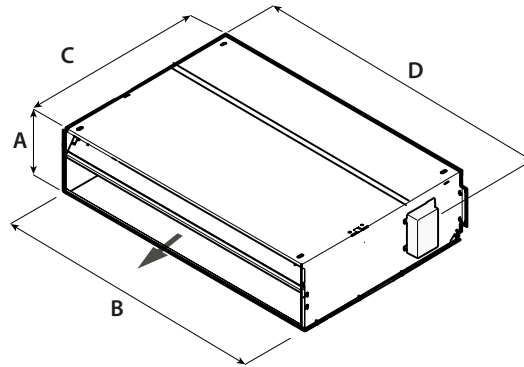

		VED430	VED440	VED530	VED540	VED630	VED640	VED730	VED740
Dimensions and weights									
A	mm	300	300	300	300	351	351	351	351
B	mm	1133	1133	1133	1133	1533	1533	1533	1533
C	mm	737	737	737	737	789	789	789	789
D	mm	1158	1158	1158	1158	1558	1558	1558	1558
Net weight	kg	41,0	43,0	42,0	47,0	57,0	60,0	58,0	61,0
		VED432	VED441	VED532	VED541	VED632	VED641	VED732	VED741
Dimensions and weights									
A	mm	300	300	300	300	351	351	351	351
B	mm	1133	1133	1133	1133	1533	1533	1533	1533
C	mm	737	737	737	737	789	789	789	789
D	mm	1158	1158	1158	1158	1558	1558	1558	1558
Net weight	kg	46,0	46,0	47,0	47,0	60,0	60,0	61,0	64,0

Aermec reserves the right to make any modifications deemed necessary. All data is subject to change without notice. Aermec does not assume responsibility or liability for errors or omissions.

Aermec S.p.A.

Via Roma, 996 - 37040 Bevilacqua (VR) - Italia
Tel. 0442633111 - Telefax 044293577
www.aermec.com