

WTG

Water-water chiller

Cooling capacity 246,6 ÷ 1959,4 kW

- Extended operating range
- Possibility of selecting between heat exchangers with 1 or 2 passes on water side



DESCRIPTION

Indoor unit producing chilled water equipped with magnetic levitation centrifugal compressors and shell & tube heat exchangers. The base, the structure and the panels are made of galvanized steel treated with polyester paint RAL 9003. The technological choices made always focus on maximum quality and efficiency, thereby achieving EER > 6 values (class A for Eurovent operating conditions).

EFFICIENCY

A High efficiency
U Very high efficiency
Both units can be silenced.

FEATURES

Two-stage, oil-free centrifugal compressor with latest-generation magnetic levitation

Oil-free operation without mechanical friction it is possible thanks to the use of magnetic levitation bearings that also ensure the total absence of vibration and low frequency noise. The compressor is equipped with an inverter for continuous load modulation by varying rpm (from 30% to 100%).

Built-in device to reduce starting current (only 6 Amps!)



Operating field

Water produced from 15 °C up to 50 °C on Condenser side and from 5 °C up to 25 °C on Evaporator side.

Flooded Evaporator

Evaporator
 — Low charge content

Condenser

— With refrigerant on shell side and water on pipe side

Acoustic chiller enclosure (option)

in galvanised sheet metal of suitable thickness insulated on the inside with sound-proofing material.

CONTROL

Microprocessor adjustment, with 7", touch screen keyboard, which allows to navigate intuitively among the various screens, allowing to modify the operating parameters and graphically view the progress of some variables in real time and the adjustment includes complete management of the alarms and their log.

ACCESSORIES

AER485P1: RS-485 interface for supervision systems with MODBUS protocol.

AERBACP: Ethernet communication Interface for protocols Bacnet/IP, Modbus TCP/IP, SNMP

FL: Flow switch.

MULTICHILLER_EVO: Control, switch-on and switch-off system of the single chillers where multiple units are installed in parallel, always ensuring constant flow rate to the evaporators.

AVX: Spring anti-vibration supports.

ACCESSORIES COMPATIBILITY

Model	Ver	1310	1490	2310	2490	3310	3400	3490	4400	4490
AER485P1	A,U
AERBACP	A,U
FL	A,U
MULTICHILLER_EVO	A,U

■ With the MULTICHILLER_EVO accessory, it is necessary to add AER485P1 for each connected unit.

Antivibration

Ver	1310	1490	2310	2490	3310	3400	3490	4400	4490
A,U	AVX (1)	AVX (1)	AVX (1)	AVX (1)	AVX (1)	AVX (1)	AVX (1)	AVX (1)	AVX (1)

(1) Contact us.

CONFIGURATOR

Field	Description
1,2,3	WTG
4,5,6,7	Size 1310, 1490, 2310, 2490, 3310, 3400, 3490, 4400, 4490
8	Version
A	High efficiency
U	Very high efficiency
9	Exchanger
1	One pass on water side

Field	Description
2	Two passes on water side
10	Set-up
°	Standard
L	Silenced
11	Power supply
°	400V ~ 3 50Hz with circuit breakers on compressors and auxiliary circuit
12	Refrigerant gas
°	R1234ze

EXCHANGERS

Over-sized tube core exchangers ensure excellent performances at full and partial loads.

Flooded evaporator: with level adjustment through an electronic valve controlled by a level sensor.

Backflow condenser: with refrigerant on shell side and water on tube side.

■ From size 1310 to 2490, heat exchangers have 2 passes on the water side

Starting from size WTG 3310, heat exchangers are available as versions with one or two passes on the water side, to meet any plant installation requirement. The dimensions of the two configurations ensure similar performances (same approach to heat exchangers). The difference is that the version with two passes on the water side due offers the convenience of water connections all on the same side, against a generally higher but nonetheless limited drop in pressure compared to the version with one pass on the water side.



PERFORMANCE SPECIFICATIONS

WTG - A

Size	1310	1490	2310	2490	3310	3400	3490	4400	4490
------	------	------	------	------	------	------	------	------	------

Exchanger: 1

Cooling performance 12 °C / 7 °C (1)

Cooling capacity	kW	-	-	-	1049,5	1199,4	1409,4	1679,3 (2)	1955,0 (2)
Input power	kW	-	-	-	194,3	202,4	245,0	286,4	334,3
Cooling total input current	A	-	-	-	310,0	324,0	389,0	457,0	532,0
EER	W/W	-	-	-	5,40	5,93	5,75	5,86	5,85
Water flow rate system side	l/h	-	-	-	180402	206174	242254	288643	336022
Pressure drop system side	kPa	-	-	-	24	32	27	29	28
Water flow rate source side	l/h	-	-	-	213103	240238	283553	336857	392518
Pressure drop source side	kPa	-	-	-	23	23	24	27	19

Exchanger: 2

Cooling performance 12 °C / 7 °C (1)

Cooling capacity	kW	349,7	469,7	699,6	899,3	1049,3	1199,2	1409,2	1679,2 (2)	1958,5 (2)
Input power	kW	66,4	81,4	132,2	158,8	196,5	204,4	248,0	290,2	339,1
Cooling total input current	A	106,0	130,0	211,0	250,0	310,0	324,0	389,0	457,0	532,0
EER	W/W	5,27	5,77	5,29	5,66	5,34	5,87	5,68	5,79	5,78
Water flow rate system side	l/h	60134	80751	120268	154630	180402	206174	242254	288643	336647
Pressure drop system side	kPa	24	14	22	50	45	49	40	44	46
Water flow rate source side	l/h	71250	94518	142500	181033	213103	240238	283553	336857	393148
Pressure drop source side	kPa	23	18	23	32	33	32	42	47	39

(1) Date 14511:2022; Water user side 12 °C / 7 °C; Water source side 30 °C / 35 °C

(2) Sizes 4400 and 4490 not included in the EUROVENT certification programme because Cooling capacity > 1500 kW

WTG - U

Size	1310	1490	2310	2490	3310	3400	3490	4400	4490
------	------	------	------	------	------	------	------	------	------

Exchanger: 1

Cooling performance 12 °C / 7 °C (1)

Cooling capacity	kW	-	-	-	736,7	869,6	999,1	1159,6	1336,9
Input power	kW	-	-	-	120,2	140,2	153,5	186,2	211,9
Cooling total input current	A	-	-	-	205,0	233,0	254,0	311,0	349,0
EER	W/W	-	-	-	6,13	6,20	6,51	6,23	6,31
Water flow rate system side	l/h	-	-	-	126626	149476	171729	199301	229777
Pressure drop system side	kPa	-	-	-	12	17	14	14	13
Water flow rate source side	l/h	-	-	-	147066	173222	197868	230962	265867
Pressure drop source side	kPa	-	-	-	16	22	18	19	18

Exchanger: 2

Cooling performance 12 °C / 7 °C (1)

Cooling capacity	kW	246,4	334,3	492,9	669,8	736,6	869,5	999,1	1159,5	1342,8
Input power	kW	40,1	50,9	80,1	105,5	120,7	140,3	154,1	187,0	212,7
Cooling total input current	A	69,0	85,0	137,0	173,0	205,0	233,0	254,0	311,0	349,0
EER	W/W	6,15	6,57	6,16	6,35	6,10	6,20	6,48	6,20	6,31
Water flow rate system side	l/h	42371	57462	84741	115160	126626	149476	171729	199301	230804
Pressure drop system side	kPa	12	7	11	28	22	26	20	21	22
Water flow rate source side	l/h	49186	66178	98371	132989	147066	173222	197868	230962	266902
Pressure drop source side	kPa	11	9	11	17	16	16	20	22	18

(1) Date 14511:2022; Water user side 12 °C / 7 °C; Water source side 30 °C / 35 °C

ELECTRIC DATA

Size	1310	1490	2310	2490	3310	3400	3490	4400	4490
------	------	------	------	------	------	------	------	------	------

Electric data

Maximum current (FLA)	A,U	A	150,0	217,0	300,0	434,0	450,0	651,0	651,0	868,0	868,0
Peak current (LRA)	A,U	A	6,0	6,0	156,0	223,0	306,0	440,0	440,0	657,0	657,0

GENERAL TECHNICAL DATA

Size			1310	1490	2310	2490	3310	3400	3490	4400	4490
Compressor											
Type	A,U	type	Centrifugal - Oil Free								
Compressor regulation	A,U	Type	Inverter								
Number	A,U	no.	1	1	2	2	3	3	3	4	4
Circuits	A,U	no.	1	1	1	1	1	1	1	1	1
Refrigerant	A,U	type	R1234ze								

Size			1310	1490	2310	2490	3310	3400	3490	4400	4490
------	--	--	------	------	------	------	------	------	------	------	------

Exchanger: 1

System side heat exchanger

Type	A,U	type	-	-	-	-	Shell and tube	Shell and tube	Shell and tube	Shell and tube	Shell and tube
Number	A,U	no.	-	-	-	-	1	1	1	1	1

Source side heat exchanger

Type	A,U	type	-	-	-	-	Shell and tube	Shell and tube	Shell and tube	Shell and tube	Shell and tube
Number	A,U	no.	-	-	-	-	1	1	1	1	1

Exchanger: 2

System side heat exchanger

Type	A,U	type	Shell and tube								
Number	A,U	no.	1	1	1	1	1	1	1	1	1

Source side heat exchanger

Type	A,U	type	Shell and tube								
Number	A,U	no.	1	1	1	1	1	1	1	1	1

SOUND DATA

Size			1310	1490	2310	2490	3310	3400	3490	4400	4490
------	--	--	------	------	------	------	------	------	------	------	------

Set-up: °

Sound data calculated in cooling mode (1)

Sound power level	A	dB(A)	89,0	91,0	92,0	94,0	94,0	93,0	96,0	94,0	97,0
	U	dB(A)	86,0	88,0	89,0	91,0	91,0	93,0	93,0	94,0	94,0

(1) Sound power calculated on the basis of measurements made in accordance with UNI EN ISO 9614-2, as required for Eurovent certification. Sound pressure (cold functioning) measured in free field, 10m away from the unit external surface (in compliance with UNI EN ISO 3744).

DIMENSIONS

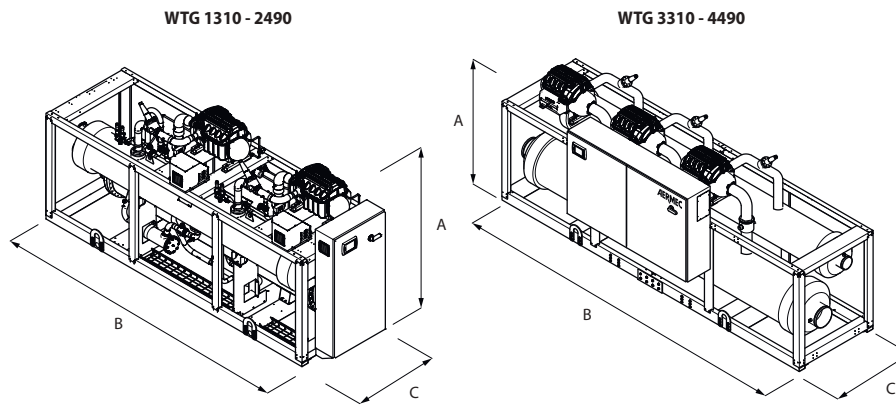

Size			1310	1490	2310	2490	3310	3400	3490	4400	4490
------	--	--	------	------	------	------	------	------	------	------	------

Exchanger: 1

Dimensions and weights

A	A,U	mm	-	-	-	-	2010	2010	2010	2280	2280
B	A,U	mm	-	-	-	-	4966	4966	4966	4966	4966
C	A,U	mm	-	-	-	-	1640	1640	1640	1732	1732

Exchanger: 2

Dimensions and weights

A	A,U	mm	1850	1970	2010	2280	2280	2280	2280	2280	2280
B	A,U	mm	3040	3040	3340	4390	3990	3990	4966	4966	4966
C	A,U	mm	1000	1240	1240	1332	1732	1836	1836	1836	1836

Aermec reserves the right to make any modifications deemed necessary. All data is subject to change without notice. Aermec does not assume responsibility or liability for errors or omissions.

Aermec S.p.A.

Via Roma, 996 - 37040 Bevilacqua (VR) - Italia
Tel. 0442633111 - Telefax 044293577
www.aermec.com