

WTX

Water-water chiller

Cooling capacity 222,9 ÷ 1958,4 kW



- High efficiency ESEER up to 9
- Extended operating range
- Possibility of selecting between heat exchangers with 1 or 2 passes on water side



DESCRIPTION

Indoor unit producing chilled water equipped with magnetic levitation centrifugal compressors and shell & tube heat exchangers. The base, the structure and the panels are made of galvanized steel treated with polyester paint RAL 9003. The technological choices made always focus on maximum quality and efficiency, thereby achieving EER > 6 values (class A for Eurovent operating conditions).

EFFICIENCY

A High efficiency
U Very high efficiency
Both units can be silenced.

FEATURES

Two-stage, oil-free centrifugal compressor with latest-generation magnetic levitation

Oil-free operation without mechanical friction it is possible thanks to the use of magnetic levitation bearings that also ensure the total absence of vibration and low frequency noise. The compressor is equipped with an inverter for continuous load modulation by varying rpm (from 30% to 100%).

Built-in device to reduce starting current (only 6 Amps!)



Operating field

Water produced from 15 °C up to 50 °C on Condenser side and from 5 °C up to 25 °C on Evaporator side.

Flooded Evaporator with subcooler

Subcooler effect

- Superheats compressor gas intake;
- Subcools thermostatic valve fluid intake;
- Increases chiller yield and ensures gas suction from compressor.

Condenser

- With refrigerant on shell side and water on pipe side

Acoustic chiller enclosure (option)

in galvanised sheet metal of suitable thickness insulated on the inside with sound-proofing material.

CONTROL

Microprocessor adjustment, with 7", touch screen keyboard, which allows to navigate intuitively among the various screens, allowing to modify the operating parameters and graphically view the progress of some variables in real time and the adjustment includes complete management of the alarms and their log.

ACCESSORIES

AER485P1: RS-485 interface for supervision systems with MODBUS protocol.

AERBACP: Ethernet communication Interface for protocols Bacnet/IP, Modbus TCP/IP, SNMP

FL: Flow switch.

MULTICHILLER_EVO: Control, switch-on and switch-off system of the single chillers where multiple units are installed in parallel, always ensuring constant flow rate to the evaporators.

AVX: Spring anti-vibration supports.

ACCESSORIES COMPATIBILITY

Model	Ver	1300	1350	2300	2350	3300	3325	3350	4325	4350
AER485P1	A,U	•	•	•	•	•	•	•	•	•
AERBACP	A,U	•	•	•	•	•	•	•	•	•
FL	A,U	•	•	•	•	•	•	•	•	•
MULTICHILLER_EVO	A,U	•	•	•	•	•	•	•	•	•

- With the MULTICHILLER_EVO accessory, it is necessary to add AER485P1 for each connected unit.

Antivibration

Ver	1300	1350	2300	2350	3300	3325	3350	4325	4350
A,U	AVX (1)	AVX (1)	AVX (1)	AVX (1)	AVX (1)	AVX (1)	AVX (1)	AVX (1)	AVX (1)

(1) Contact us.

CONFIGURATOR

Field	Description
1,2,3	WTX
4,5,6,7	Size 1300, 1350, 2300, 2350, 3300, 3325, 3350, 4325, 4350
8	Efficiency
A	High efficiency
U	Very high efficiency
9	Exchanger
1	One pass on water side (1)

Field	Description
2	Two passes on water side
10	Version
°	Standard
L	Silenced
11	Power supply
°	400V ~ 3 50Hz with circuit breakers on compressors and auxiliary circuit

(1) Option available only for size from 3300 to 4350.

EXCHANGERS

Over-sized tube core exchangers ensure excellent performances at full and partial loads.

Flooded evaporator: with level adjustment through an electronic valve controlled by a level sensor.

Backflow condenser: with refrigerant on shell side and water on tube side.

- From size 1300 to 2350, heat exchangers have 2 passes on the water side

Starting from size WTX 3300, heat exchangers are available as versions with one or two passes on the water side, to meet any plant installation requirement. **The dimensions of the two configurations ensure similar performances** (same approach to heat exchangers). **The difference is that the version with two passes on the water side due offers the convenience of water connections all on the same side**, against a generally higher but nonetheless limited drop in pressure compared to the version with one pass on the water side.



PERFORMANCE SPECIFICATIONS

WTX - A

Size		1300	1350	2300	2350	3300	3325	3350	4325	4350
Exchanger: 1										
Cooling performance 12 °C / 7 °C (1)										
Cooling capacity	kW	-	-	-	-	1054,4	1214,3	1466,1	1716,2 (2)	1955,0 (2)
Input power	kW	-	-	-	-	211,4	219,9	281,6	315,3	375,1
Cooling total input current	A	-	-	-	-	317,0	356,0	435,0	503,0	580,0
EER	W/W	-	-	-	-	4,99	5,52	5,21	5,44	5,21
Water flow rate system side	l/h	-	-	-	-	181266	208751	252017	294970	336022
Pressure drop system side	kPa	-	-	-	-	32	39	31	24	31
Water flow rate source side	l/h	-	-	-	-	218376	247239	301544	350417	402059
Pressure drop source side	kPa	-	-	-	-	31	38	31	42	31
Exchanger: 2										
Cooling performance 12 °C / 7 °C (1)										
Cooling capacity	kW	351,3	488,5	702,8	899,4	1054,3	1215,9	1466,0	1715,9 (2)	1958,4 (2)
Input power	kW	70,8	94,3	141,8	164,1	212,6	220,6	283,8	318,8	380,0
Cooling total input current	A	106,0	145,0	212,0	255,0	317,0	356,0	435,0	503,0	580,0
EER	W/W	4,96	5,18	4,96	5,48	4,96	5,51	5,17	5,38	5,15
Water flow rate system side	l/h	60422	84006	120844	154630	181266	209053	252017	294970	336647
Pressure drop system side	kPa	32	30	40	33	54	77	54	60	82
Water flow rate source side	l/h	72792	100515	145584	183481	218376	247235	301544	350417	402062
Pressure drop source side	kPa	31	33	35	28	28	35	33	41	53

(1) Date 14511:2022; Water user side 12 °C / 7 °C; Water source side 30 °C / 35 °C

(2) Sizes 4325 and 4350 not included in the EUROVENT certification programme because Cooling capacity > 1500 kW

WTX - U

Size		1300	1350	2300	2350	3300	3325	3350	4325	4350
Exchanger: 1										
Cooling performance 12 °C / 7 °C (1)										
Cooling capacity	kW	-	-	-	-	669,0	869,6	1002,7	1179,6	1336,9
Input power	kW	-	-	-	-	112,2	144,9	166,9	195,3	222,3
Cooling total input current	A	-	-	-	-	180,0	237,0	273,0	316,0	364,0
EER	W/W	-	-	-	-	5,96	6,00	6,01	6,04	6,01
Water flow rate system side	l/h	-	-	-	-	115004	149476	172333	202737	229777
Pressure drop system side	kPa	-	-	-	-	12	18	14	10	14
Water flow rate source side	l/h	-	-	-	-	135049	175273	202156	237660	269542
Pressure drop source side	kPa	-	-	-	-	12	17	13	17	13
Exchanger: 2										
Cooling performance 12 °C / 7 °C (1)										
Cooling capacity	kW	222,9	334,1	445,9	559,7	669,0	840,1	1006,1	1191,4	1342,6
Input power	kW	37,5	55,9	75,1	94,3	112,5	140,7	167,2	198,4	223,4
Cooling total input current	A	60,0	91,0	120,0	158,0	180,0	237,0	273,0	316,0	364,0
EER	W/W	5,95	5,98	5,94	5,93	5,95	5,97	6,02	6,01	6,01
Water flow rate system side	l/h	38335	57444	76669	96214	115004	144425	172942	204799	230804
Pressure drop system side	kPa	12	13	16	12	21	32	24	26	37
Water flow rate source side	l/h	45016	67385	90033	113067	135049	169344	202690	240041	270255
Pressure drop source side	kPa	12	14	13	10	10	15	14	18	23

(1) Date 14511:2022; Water user side 12 °C / 7 °C; Water source side 30 °C / 35 °C

ENERGY INDICES (REG. 2016/2281 EU)

Size			1300	1350	2300	2350	3300	3325	3350	4325	4350
Exchanger: 1											
SEER - 12/7 (EN14825: 2018) (1)											
SEER	A	W/W	-	-	-	-	8,25	8,64	8,78	8,76	8,95
	U	W/W	-	-	-	-	9,70	9,54	9,85	9,59	9,92
Seasonal efficiency	A	%	-	-	-	-	326,8%	342,6%	348,2%	347,2%	354,8%
	U	%	-	-	-	-	384,8%	378,4%	390,8%	380,6%	393,7%
SEPR - (EN 14825: 2018) High temperature (2)											
SEPR	A	W/W	-	-	-	-	8,75	9,92	9,33	9,71	9,35
	U	W/W	-	-	-	-	11,80	11,36	11,44	11,49	11,47
Exchanger: 2											
SEER - 12/7 (EN14825: 2018) (1)											
SEER	A	W/W	8,40	8,59	8,19	8,76	8,03	8,34	8,45	8,32	8,39
	U	W/W	9,69	9,07	9,47	9,73	9,54	9,31	9,66	9,28	9,60
Seasonal efficiency	A	%	332,9%	340,6%	324,5%	347,3%	318,1%	330,4%	334,9%	329,8%	332,6%
	U	%	384,4%	359,9%	375,6%	386,3%	378,6%	369,5%	383,5%	368,1%	380,8%
SEPR - (EN 14825: 2018) High temperature (2)											
SEPR	A	W/W	8,26	9,17	8,25	9,70	8,64	9,75	9,17	9,48	9,08
	U	W/W	11,65	11,34	11,62	11,17	11,70	11,20	11,37	11,30	11,31

(1) Calculation performed with FIXED water flow rate and VARIABLE outlet temperature.

(2) Calculation performed with FIXED water flow rate.

ELECTRIC DATA

Size			1300	1350	2300	2350	3300	3325	3350	4325	4350
Electric data											
Maximum current (FLA)	A,U	A	135,0	210,0	270,0	420,0	405,0	405,0	630,0	630,0	630,0
Peak current (LRA)	A,U	A	6,0	6,0	141,0	216,0	276,0	276,0	426,0	426,0	426,0

GENERAL TECHNICAL DATA

Size			1300	1350	2300	2350	3300	3325	3350	4325	4350
Compressor											
Type	A,U	type									
Compressor regulation	A,U	Type									
Number	A,U	no.	1	1	2	2	3	3	3	4	4
Circuits	A,U	no.	1	1	1	1	1	1	1	1	1
Refrigerant	A,U	type									

Size			1300	1350	2300	2350	3300	3325	3350	4325	4350
------	--	--	------	------	------	------	------	------	------	------	------

Exchanger: 1

System side heat exchanger

Type	A,U	type	-	-	-	-	Shell and tube	Shell and tube	Shell and tube	Shell and tube	Shell and tube
Number	A,U	no.	-	-	-	-	1	1	1	1	1
Connections (in/out)	A,U	Type	-	-	-	-	Grooved joints	Grooved joints	Grooved joints	Grooved joints	Grooved joints
Sizes (in/out)	A,U	Ø	-	-	-	-	6"	10"	10"	6"	8"

Source side heat exchanger

Type	A,U	type	-	-	-	-	Shell and tube	Shell and tube	Shell and tube	Shell and tube	Shell and tube
Number	A,U	no.	-	-	-	-	1	1	1	1	1
Connections (in/out)	A,U	Type	-	-	-	-	Grooved joints	Grooved joints	Grooved joints	Grooved joints	Grooved joints
Sizes (in/out)	A,U	Ø	-	-	-	-	6"	6"	10"	8"	8"

Exchanger: 2

System side heat exchanger

Type	A,U	type	Shell and tube	Shell and tube	Shell and tube	Shell and tube	Shell and tube	Shell and tube	Shell and tube	Shell and tube	Shell and tube
Number	A,U	no.	1	1	1	1	1	1	1	1	1
Connections (in/out)	A,U	Type	Grooved joints	Grooved joints	Grooved joints	Grooved joints	Grooved joints	Grooved joints	Grooved joints	Grooved joints	Grooved joints
Sizes (in/out)	A,U	Ø	5"	5"	5"	6"	6"	10"	6"	8"	8"

Source side heat exchanger

Type	A,U	type	Shell and tube	Shell and tube	Shell and tube	Shell and tube	Shell and tube	Shell and tube	Shell and tube	Shell and tube	Shell and tube
Number	A,U	no.	1	1	1	1	1	1	1	1	1
Connections (in/out)	A,U	Type	Grooved joints	Grooved joints	Grooved joints	Grooved joints	Grooved joints	Grooved joints	Grooved joints	Grooved joints	Grooved joints
Sizes (in/out)	A,U	Ø	5"	5"	6"	6"	6"	6"	8"	8"	8"

SOUND DATA

Size	1300	1350	2300	2350	3300	3325	3350	4325	4350
------	------	------	------	------	------	------	------	------	------

Efficiency: A

Sound data calculated in cooling mode (1)

Sound power level	°	dB(A)	90,0	91,0	93,0	93,5	96,0	95,5	97,0	98,5	100,0
	L	dB(A)	84,0	85,0	87,0	87,5	90,0	89,5	91,0	92,5	94,0

Efficiency: U

Sound data calculated in cooling mode (1)

Sound power level	°	dB(A)	87,0	88,0	90,0	88,0	90,0	91,0	94,0	94,0	97,0
	L	dB(A)	81,0	82,0	84,0	82,0	84,0	85,0	88,0	88,0	91,0

(1) Sound power calculated on the basis of measurements made in accordance with UNI EN ISO 9614-2, as required for Eurovent certification. Sound pressure (cold functioning) measured in free field, 10m away from the unit external surface (in compliance with UNI EN ISO 3744).

Size	1300	1350	2300	2350	3300	3325	3350	4325	4350
------	------	------	------	------	------	------	------	------	------

Efficiency: A

Sound data calculated in cooling mode (1)

Sound power level	°	dB(A)	90,0	91,0	93,0	93,5	96,0	95,5	97,0	98,5	100,0
	L	dB(A)	84,0	85,0	87,0	87,5	90,0	89,5	91,0	92,5	94,0

Efficiency: U

Sound data calculated in cooling mode (1)

Sound power level	°	dB(A)	87,0	88,0	90,0	88,0	90,0	91,0	94,0	94,0	97,0
	L	dB(A)	81,0	82,0	84,0	82,0	84,0	85,0	88,0	88,0	91,0

(1) Sound power calculated on the basis of measurements made in accordance with UNI EN ISO 9614-2, as required for Eurovent certification. Sound pressure (cold functioning) measured in free field, 10m away from the unit external surface (in compliance with UNI EN ISO 3744).

DIMENSIONS

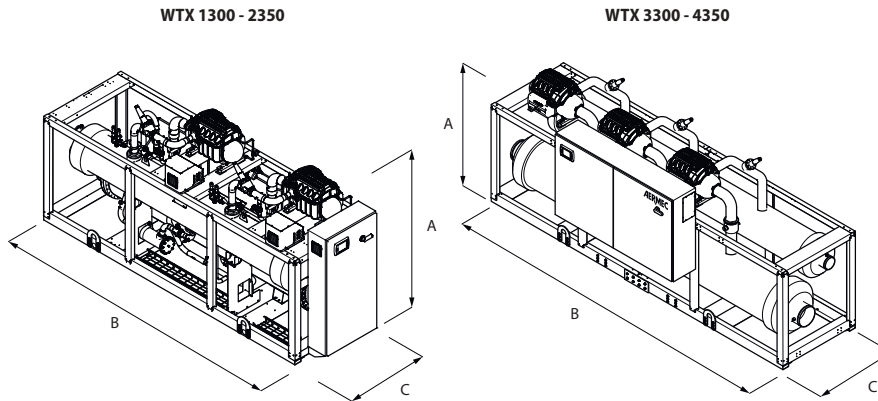

Size	1300	1350	2300	2350	3300	3325	3350	4325	4350
------	------	------	------	------	------	------	------	------	------

Exchanger: 1

Dimensions and weights

	A,U	mm	-	-	-	-	1970	2010	2010	2010	2280
A	A,U	mm	-	-	-	-	4966	4966	4966	4966	4966
B	A,U	mm	-	-	-	-	1640	1640	1640	1640	1732
C	A,U	mm	-	-	-	-	4090	4430	5120	5690	6640
Empty weight	A,U	kg	-	-	-	-	4430	4810	5620	6250	7450
Weight functioning	A,U	kg	-	-	-	-					

Exchanger: 2

Dimensions and weights

	A,U	mm	1850	1950	1970	2010	2240	2280	2280	2280	2280
A	A,U	mm	3040	3040	3340	3440	3990	3990	3990	4966	4966
B	A,U	mm	1000	1000	1240	1240	1732	1732	1836	1836	1836
C	A,U	mm	2190	2370	2770	3390	5440	5730	6630	7200	7380
Empty weight	A,U	kg	2350	2560	3010	3740	6170	6480	7540	8160	8400
Weight functioning	A,U	kg									

Aermec reserves the right to make any modifications deemed necessary. All data is subject to change without notice. Aermec does not assume responsibility or liability for errors or omissions.

Aermec S.p.A.

Via Roma, 996 - 37040 Bevilacqua (VR) - Italia
Tel. 0442633111 - Telefax 044293577
www.aermec.com