

WWM

Water cooled heat pump reversible water side

Cooling capacity 96 kW
Heating capacity 110 kW



- Compact module
- Single or dual refrigerant circuit
- Reliable and modular
- Max 2 levels of stackable units
- Up to 36 connectable units (see the modularity options)
- Easy installation and maintenance



DESCRIPTION

Water-water offering chilled/hot water, designed to meet air conditioning needs in residential/commercial complexes or industrial applications. These are indoor units with hermetic scroll compressors, system side heat exchanger and plate source.

The base, the structure and the panels are made of galvanized steel treated with polyester paint RAL 9003.

FEATURES

The precise choice of components, the special configuration, and the possibility to connect several independent modules and manage them as if they were a single unit are all aspects that guarantee maximum output at full load, whilst ensuring continuous adaptation to the real service needs.

Bus Bar, to facilitate the electrical connections.

Modularity

Thanks to its modular construction, the installation can be adapted to suit specific system development needs whilst guaranteeing improved safety and reliability.

As a result, the cooling capacity can be easily increased over time, at a limited cost.

WWM consists of independent 96 kW modules that can be linked together to reach a capacity of 3456 kW.

With WWM, you can combine up to 36 units designed to minimise the overall dimensions.

The modules are easy to install and link together from the hydronic point of view, thanks to the connections with grooved joints.

Refrigerant circuit

The refrigerant circuit can easily be disconnected from the unit, maintaining all the functions of the hydronic circuit to ensure correct system operation.

Hydraulic components

WWM version PN10 has the **switch**; WWM version PN21 mounts the **transmitter**.

Fitted as standard, with **butterfly shut-off valves** on both hydronic lines for disconnecting the circuit when maintenance needs to be carried out.

In the event of a variable flow rate, the **motorised hydronic valves** can intercept one module or more in order to reduce the flow rate when there is a low thermal load level.

Very quiet

The WWM units stand out for their quiet operation.

Accurate unit sound-proofing, using good-quality sound absorbent material, means all the units work at low noise levels.

Units in parallel

The MULTICHILLER_EVO (accessory) allows up to 9 units to be managed in parallel mode.

This accessory allows to maximise the total efficiency to the system under to work load, external air temperature conditions and water produced.

Each unit has its own electrical panel, guaranteeing continuity even if one module malfunctions or goes into lockout.

CONTROL

Microprocessor adjustment, with keyboard and LCD display, for easy access on the unit is a menu available in several languages.

— The presence of a programmable timer allows functioning time periods and a possible second set-point to be set.

— The adjustment system includes the complete management of alarms and the alarm log.

ACCESSORIES

AER485P1: RS-485 interface for supervising systems with MODBUS protocol. 1 accessory is provided for each unit control board.

AERBACP: Ethernet communication interface for Bacnet/IP, Modbus TCP/IP, SNMP protocols. 1 accessory is provided for each unit control board.

AERNET: The device allows the control, the management and the remote monitoring of a Chiller with a PC, smartphone or tablet using Cloud connection. AERNET works as Master while every unit connected is configured as Slave (max. 6 control boards). Also, with a simple click is possible to save a log file with all the connected unit datas in the personal terminal for post analysis.

KWWM: Kit containing 4 caps with a diameter of 6" for the water manifolds.
MULTICHILLER-EVO: Control, switch-on and switch-off system of the single chillers where multiple units are installed in parallel (max. no. 9), always ensuring constant flow rate to the evaporators.

PR4: Remote panel with LCD display and touch keyboard that allows carrying out the basic controls, the programming of time ranges and the signalling of the alarms of a single unit.

- The accessory PR4 should only be combined with the RS485 communication interface when the serial port is occupied by another device.

FACTORY FITTED ACCESSORIES

CRATE_WWMH-A: Special crate for transport

ACCESSORIES COMPATIBILITY

| Accessory | WWM05001H | WWM05001° | WWM05002H | WWM05002° |
|------------------|-----------|-----------|-----------|-----------|
| AER485P1 | • | • | • | • |
| AERBACP | • | • | • | • |
| AERNET | • | • | • | • |
| KWWM | • | • | • | • |
| MULTICHILLER-EVO | • | • | • | • |

For the control with MULTICHILLER EVO, nr.1 accessory AER485P1 is mandatory for every WWM of the system.

PR4

| Accessory | WWM05001H | WWM05001° | WWM05002H | WWM05002° |
|-----------|-----------|-----------|-----------|-----------|
| PR4 | • | • | • | • |

Special crate for transport

| Accessory | WWM05001H | WWM05001° | WWM05002H | WWM05002° |
|--------------|-----------|-----------|-----------|-----------|
| CRATE_WWMH-A | • | • | • | • |
| CRATE_WWM° | | • | | • |

- CRATE_WWM°: 100 kg, CRATE_WWMH-A: 130 kg

Cable entries box

| Accessory | WWM05001H | WWM05001° | WWM05002H | WWM05002° |
|-----------|-----------|-----------|-----------|-----------|
| KREC_WWM | • | • | • | • |

Water filter

| Accessory | WWM05001H | WWM05001° | WWM05002H | WWM05002° |
|-------------|-----------|-----------|-----------|-----------|
| KITIDRO_WWM | • | • | • | • |

CONFIGURATOR

| Field | Description |
|---------|--|
| 1,2,3 | WWM |
| 4,5,6,7 | Size 0500 |
| 8 | Operating field (1) |
| ° | Standard mechanic thermostatic valve |
| 9 | Model |
| 1 | Single refrigerant circuit |
| 2 | Double refrigerant circuit |
| 10 | Hydraulic pressure rating |
| 1 | 145 psi (PN10) |
| 3 | 300 psi (PN21) |
| 11 | Hydraulic headers kit |
| H | 6" Headers kit - PN21 standard carbon steel pipes declared in accordance with EN 10255 |
| ° | No headers provided |

CRATE_WWM°: Special crate for transport

KITIDRO_WWM: Water filter with connection pipe (diameter 6") with drain tap and additional bulb well (diameter ½") available to the installer.

KREC_WWM: Cable entries box in order to facilitate the electrical installation.

| Field | Description |
|-------|--|
| 12 | Power connection |
| B | With bus bars |
| ° | Without bus bars |
| 13 | Power supply |
| ° | 400V ~ 3 50Hz with magnet circuit breakers |
| 14 | Electrical panel SCCR |
| ° | 10 kA control panel |
| 15 | Peak current reduction |
| R | With power factor device (2) |
| ° | Without power factor device |
| 16 | Field for future development |
| ° | - |

(1) Water produced up to +4 °C

(2) Factory installed

MODULARITY OPTIONS

**CONFIGURATION 1:
IN LINE**

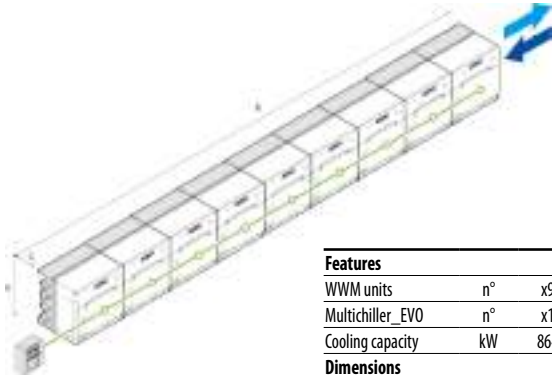

| Features | | |
|------------------|----|-------|
| WWM units | n° | x9 |
| Multichiller_EVO | n° | x1 |
| Cooling capacity | kW | 864 |
| Dimensions | | |
| A | mm | 1300 |
| B | mm | 11970 |
| C | mm | 1150 |

**CONFIGURATION 2:
BACK TO BACK**

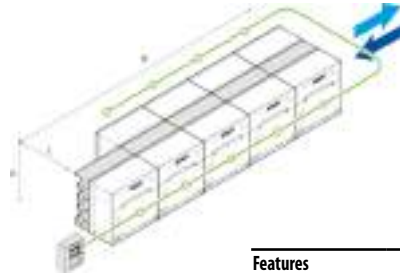

| Features | | |
|------------------|----|------|
| WWM units | n° | x9 |
| Multichiller_EVO | n° | x1 |
| Cooling capacity | kW | 864 |
| Dimensions | | |
| A | mm | 1300 |
| B | mm | 6650 |
| C | mm | 1850 |

**CONFIGURATION 3.1:
STACK IN LINE**

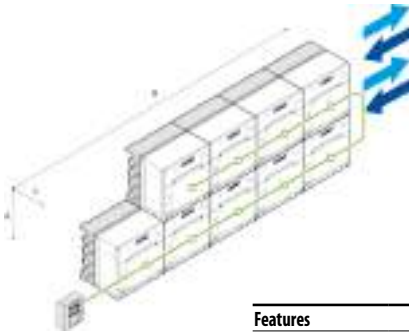

| Features | | |
|------------------|----|------|
| WWM units | n° | x9 |
| Multichiller_EVO | n° | x1 |
| Cooling capacity | kW | 864 |
| Dimensions | | |
| A | mm | 2600 |
| B | mm | 6650 |
| C | mm | 1150 |

**CONFIGURATION 3.2:
STACK IN LINE**

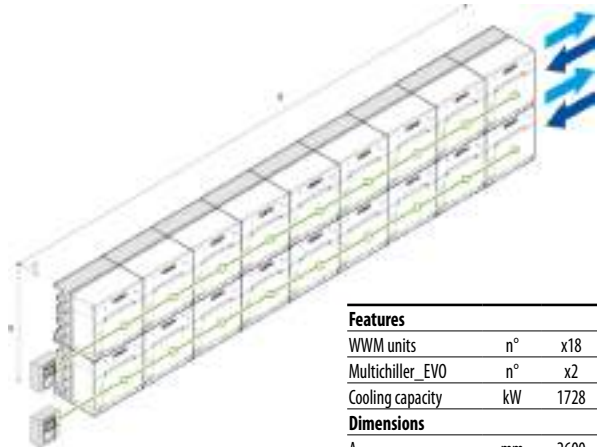

| Features | | |
|------------------|----|-------|
| WWM units | n° | x18 |
| Multichiller_EVO | n° | x2 |
| Cooling capacity | kW | 1728 |
| Dimensions | | |
| A | mm | 2600 |
| B | mm | 11970 |
| C | mm | 1150 |

**CONFIGURATION 4.1:
STACK IN LINE BACK TO BACK**

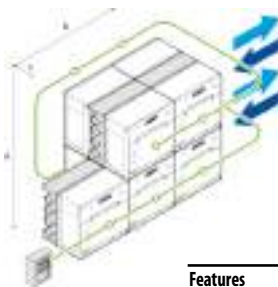

| Features | | |
|------------------|----|------|
| WWM units | n° | x9 |
| Multichiller_EVO | n° | x1 |
| Cooling capacity | kW | 864 |
| Dimensions | | |
| A | mm | 2600 |
| B | mm | 3990 |
| C | mm | 1850 |

**CONFIGURATION 4.2:
STACK IN LINE BACK TO BACK**

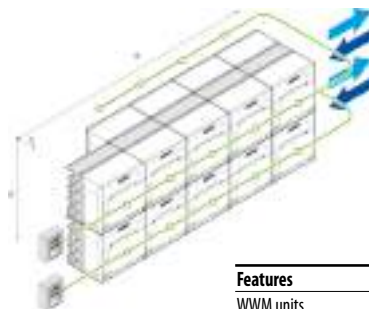

| Features | | |
|------------------|----|------|
| WWM units | n° | x18 |
| Multichiller_EVO | n° | x2 |
| Cooling capacity | kW | 1728 |
| Dimensions | | |
| A | mm | 2600 |
| B | mm | 6650 |
| C | mm | 1850 |

**CONFIGURATION 5.1:
STACK IN LINE BACK TO BACK DOUBLE**

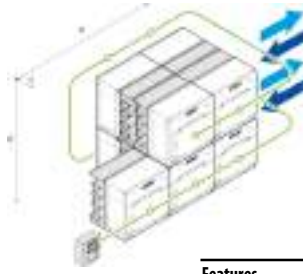

| Features | | |
|------------------|----|------|
| WWM units | n° | x9 |
| Multichiller_EVO | n° | x1 |
| Cooling capacity | kW | 864 |
| Dimensions | | |
| A | mm | 2600 |
| B | mm | 3990 |
| C | mm | 2300 |

**CONFIGURATION 5.2:
STACK IN LINE BACK TO BACK DOUBLE**

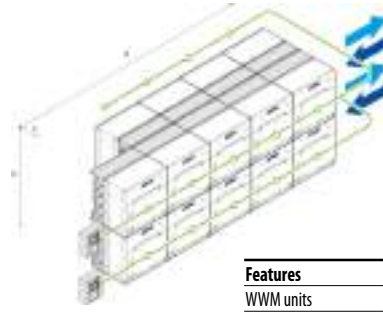

| Features | | |
|------------------|----|------|
| WWM units | n° | x18 |
| Multichiller_EVO | n° | x2 |
| Cooling capacity | kW | 1728 |
| Dimensions | | |
| A | mm | 2600 |
| B | mm | 6650 |
| C | mm | 2300 |

**CONFIGURATION 5.3:
STACK IN LINE BACK TO BACK DOUBLE**

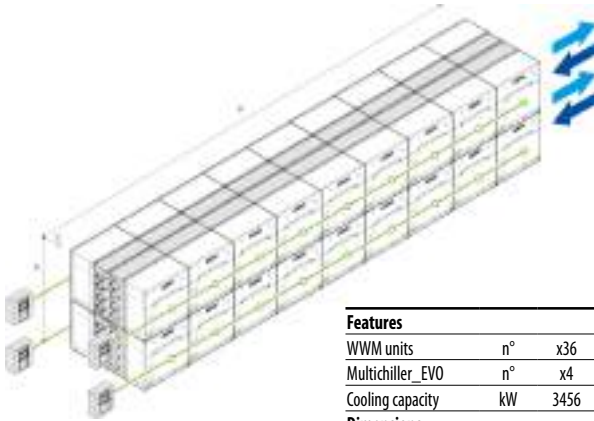

| Features | | |
|------------------|----|-------|
| WWM units | n° | x36 |
| Multichiller_EVO | n° | x4 |
| Cooling capacity | kW | 3456 |
| Dimensions | | |
| A | mm | 2600 |
| B | mm | 11970 |
| C | mm | 2300 |

EASY MAINTENANCE

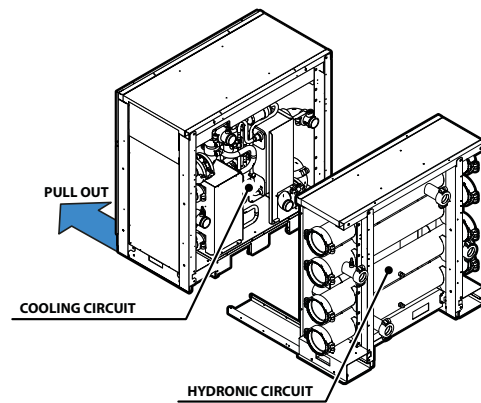

PERFORMANCE SPECIFICATIONS

WWM - Single refrigerant circuit "1" - Double refrigerant circuit "2"

| | | WWM05001° | WWM05002° |
|--|-----|-----------|-----------|
| Cooling performance 12 °C / 7 °C (1) | | | |
| Cooling capacity | kW | 96,0 | 95,2 |
| Input power | kW | 20,3 | 20,0 |
| Cooling total input current | A | 40,0 | 40,0 |
| EER | W/W | 4,74 | 4,76 |
| Water flow rate source side | l/h | 20046 | 19895 |
| Pressure drop source side | kPa | 34 | 23 |
| Water flow rate system side | l/h | 16528 | 16384 |
| Pressure drop system side | kPa | 24 | 17 |
| Heating performance 40 °C / 45 °C (2) | | | |
| Heating capacity | kW | 109,2 | 110,0 |
| Input power | kW | 24,8 | 24,1 |
| Heating total input current | A | 48,0 | 48,0 |
| COP | W/W | 4,41 | 4,57 |
| Water flow rate system side | l/h | 18943 | 19092 |
| Pressure drop system side | kPa | 30 | 21 |
| Water flow rate source side | l/h | 24430 | 24809 |
| Pressure drop source side | kPa | 52 | 39 |

(1) Date 14511:2022; Water user side 12 °C / 7 °C; Water source side 30 °C / 35 °C

(2) Date 14511:2022; Water user side 40 °C / 45 °C; Water source side 10 °C / 7 °C

ENERGY DATA

| | | WWM05001° | WWM05002° |
|--|-----|-----------|-----------|
| SEER - 12/7 (EN14825:2018) with standard fans (1) | | | |
| SEER | W/W | 6,12 | 5,37 |
| Seasonal efficiency | % | 241,8% | 211,8% |
| UE 813/2013 performance in average ambient conditions (average) - 55 °C - Pdesignh ≤ 400 kW (2) | | | |
| Pdesignh | kW | 138 | 140 |
| SCOP | W/W | 4,83 | 4,68 |
| ηsh | % | 185,0% | 179,0% |

(1) Calculation performed with FIXED water flow rate and VARIABLE outlet temperature.

(2) Efficiencies for average temperature applications (55 °C)

ELECTRIC DATA

| | | WWM05001° | WWM05002° |
|-----------------------|---|-----------|-----------|
| Electric data | | | |
| Maximum current (FLA) | A | 62,0 | 62,0 |
| Peak current (LRA) | A | 148,9 | 148,9 |

GENERAL TECHNICAL DATA

| | | WWM05001° | WWM05002° |
|--|-------|----------------|----------------|
| Compressor | | | |
| Type | type | Scroll | Scroll |
| Number | no. | 2 | 2 |
| Circuits | no. | 1 | 2 |
| Refrigerant | type | R410A | R410A |
| Source side heat exchanger | | | |
| Type | type | Brazed plate | Brazed plate |
| Number | no. | 1 | 1 |
| Connections (in/out) | Type | Grooved joints | Grooved joints |
| Sizes (in/out) | Ø | 6" | 6" |
| System side heat exchanger | | | |
| Type | type | Brazed plate | Brazed plate |
| Number | no. | 1 | 1 |
| Connections (in/out) | Type | Grooved joints | Grooved joints |
| Sizes (in/out) | Ø | 6" | 6" |
| Sound data calculated in cooling mode (1) | | | |
| Sound power level | dB(A) | 81,0 | 81,0 |
| Sound pressure level (10 m) | dB(A) | 49,5 | 49,5 |

(1) Sound power calculated on the basis of measurements made in accordance with UNI EN ISO 9614-2, as required for Eurovent certification. Sound pressure (cold functioning) measured in free field, 10m away from the unit external surface (in compliance with UNI EN ISO 3744).

DIMENSIONS

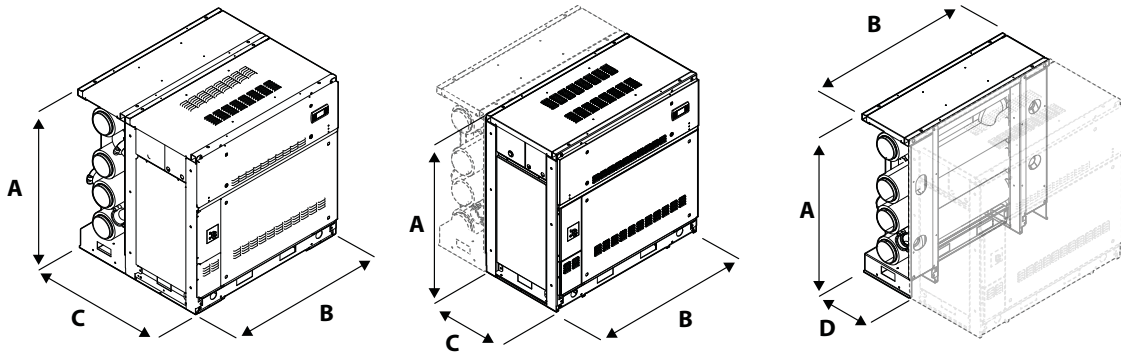

| | | WWM05001° | WWM05001H | WWM05002° | WWM05002H |
|--|----|-----------|-----------|-----------|-----------|
| Dimensions and weights | | | | | |
| A | mm | 1300 | 1300 | 1300 | 1300 |
| B | mm | 1330 | 1330 | 1330 | 1330 |
| C | mm | 775 | 1150 | 775 | 1150 |
| D | mm | - | 452 | - | 452 |
| Weights | | | | | |
| Weight empty + packaging | kg | 700 | 930 | 700 | 930 |
| Weight functioning | kg | 711 | 1042 | 711 | 1042 |
| Empty weight + packaging (with bus bars) | kg | 736 | 966 | 736 | 966 |
| Weight functioning (with bus bars) | kg | 747 | 1078 | 747 | 1078 |
| Hydraulic headers kit | | | | | |
| Weight empty + packaging | kg | - | 230 | - | 230 |
| Weight functioning | kg | - | 330 | - | 330 |

Aermec reserves the right to make any modifications deemed necessary.
All data is subject to change without notice. Aermec does not assume responsibility or liability for errors or omissions.

Aermec S.p.A.
Via Roma, 996 - 37040 Bevilacqua (VR) - Italia
Tel. 0442633111 - Telefax 044293577
www.aermec.com